

# Technical Data

Pump Name

EVMS-K1 16N5Q1BEG/0.75 TT

Customer	Date	2024-06-14	Company
Contact	Item no.		Issued by
Phone	Project		Phone
E-mail	Project ID	Proiect redenumit 2024-06-14 09:53:20	E-mail

## Requested data

1	Pump type	VERTICAL MULTISTAGE PUMP	Fluid	Water
2	Number of pumps / Reserve	1 / 0	Liquid temperature	°C
3	Flow	m³/h	Kin. viscosity	mm²/s
4	Head	m	Vapour pressure	bar
5	Geodetic head	m	PH value	
6	Inlet pressure (pin)	bar	Density	kg/m³
7	Available system NPSH		Solids	Weight %
8	Ambient temperature	°C		

## Pump

9	Pump Name	EVMS-K1 16N5Q1BEG/0.75 TT	Frequency	Hz	50	
10	Design	VERTICAL MULTISTAGE PUMP	Installation type		Oval flange (STANDARD)	
11	Manufacturer	EBARA	Impeller Diameter	Max.	mm	
12	Speed	rpm		2850	Designed	mm
13	No. of Stage			16	Min.	mm
14	Connection	Suction side	Flow	Operating	m³/h	
15	Connection	Discharge side		Max-	m³/h	2.4
16	Max Working Pressure	bar		16	Min-	m³/h
17	Shut-off head	bar	9.02	Head	Operating	m
18	Total weight	kg	See the table of "Dimensions".		- (Qmax.)	m
19	Shaft power	kW			- (Qmin.)	m
20			Max. Shaft Power at max. impeller	kW	0.67	
21	Required pump NPSH	m	Efficiency	%		

## Materials

22	Impeller	AISI 304		
23	Intermediate casing	AISI 304		
24	Bottom casing	AISI 304		
25	Shaft	AISI 304		
26	O-ring	EPDM		
27				

## Motor

28	Manufacturer	ETM	Insulation class	F	
29	Type	TEFC_EVMS-K1 16/0.75 TT_400_Three Phase	Phases	3~	
30	Specific design	IE3 / 50 Hz / Pole pairs 1	Frame size	80	
31	Rated power	kW	0.75	Weight	kg
32	Number of poles		2	Electric voltage	V
33	Speed	rpm	2845	Electric current	A
34	Degree of protection		IP 55		
35					

## Remarks

# Performance Curve

Pump Name

EVMS-K1 16N5Q1BEG/0.75 TT

Customer	Date	2024-06-14	Company
Contact	Item no.		Issued by
Phone	Project		Phone
E-mail	Project ID	Proiect redenumit 2024-06-14 09:53:20	E-mail

## Requested data

1	Flow	m³/h	
2	Head	m	
3	Geodetic head	m	

## Pump

Operating flow	m³/h		Frequency	Hz	50
Operating head	m		Number of poles		2
Impeller diameter designed	mm	71	Speed	rpm	2850

Test standard: ISO 9906:2012 - Grade3B

Water; 20°C; 998.3kg/m³; 1mm²/s

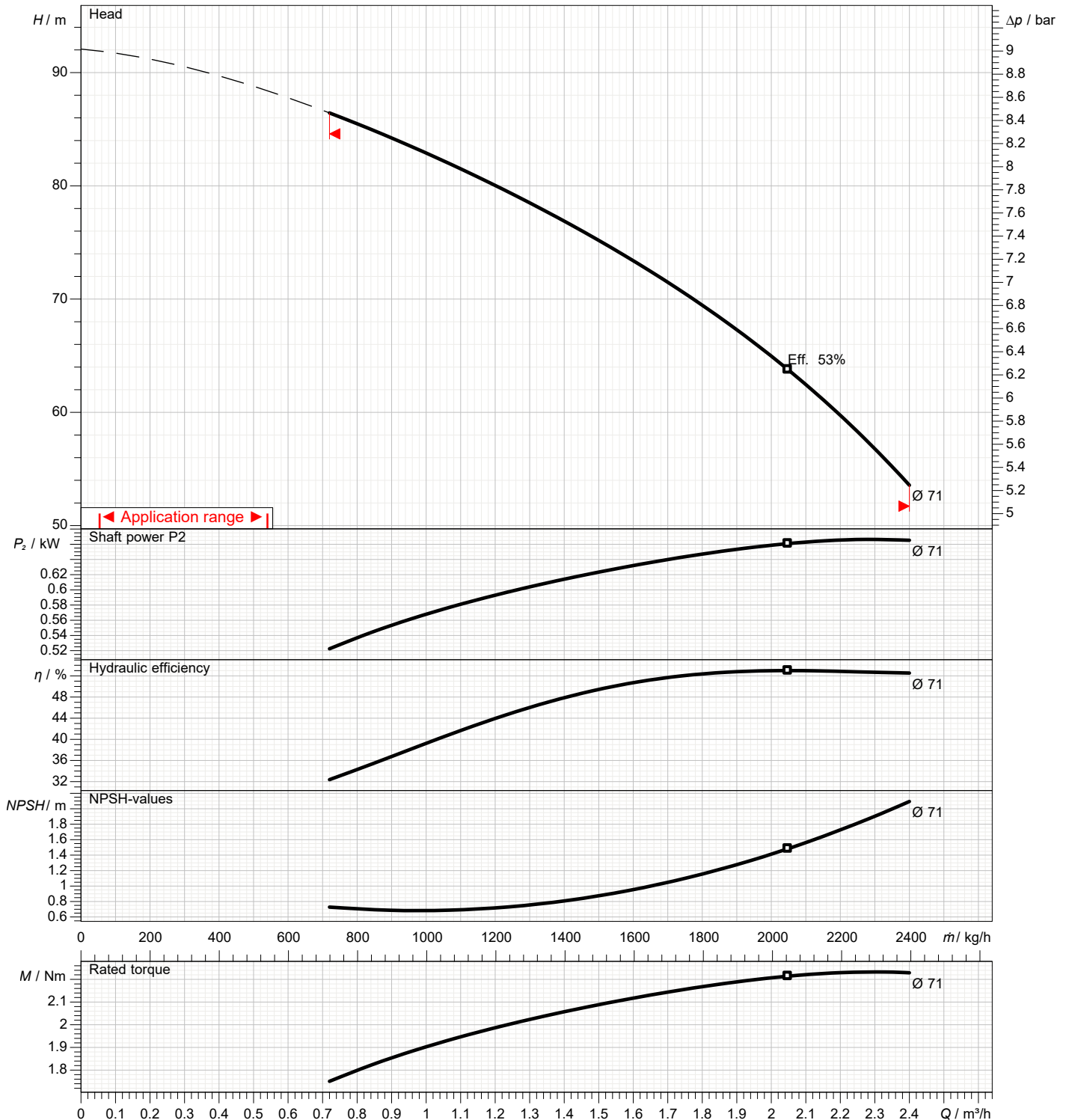

# Dimensions

Pump name EVMS-K1 16N5Q1BEG/0.75 TT

Customer	Date 2024-06-14	Company
Contact	Item no.	Issued by
Phone	Project	Phone
E-mail	Project ID Proiect redenumit 2024-06-14 09:53:20	E-mail

## EVMS(L)-K1

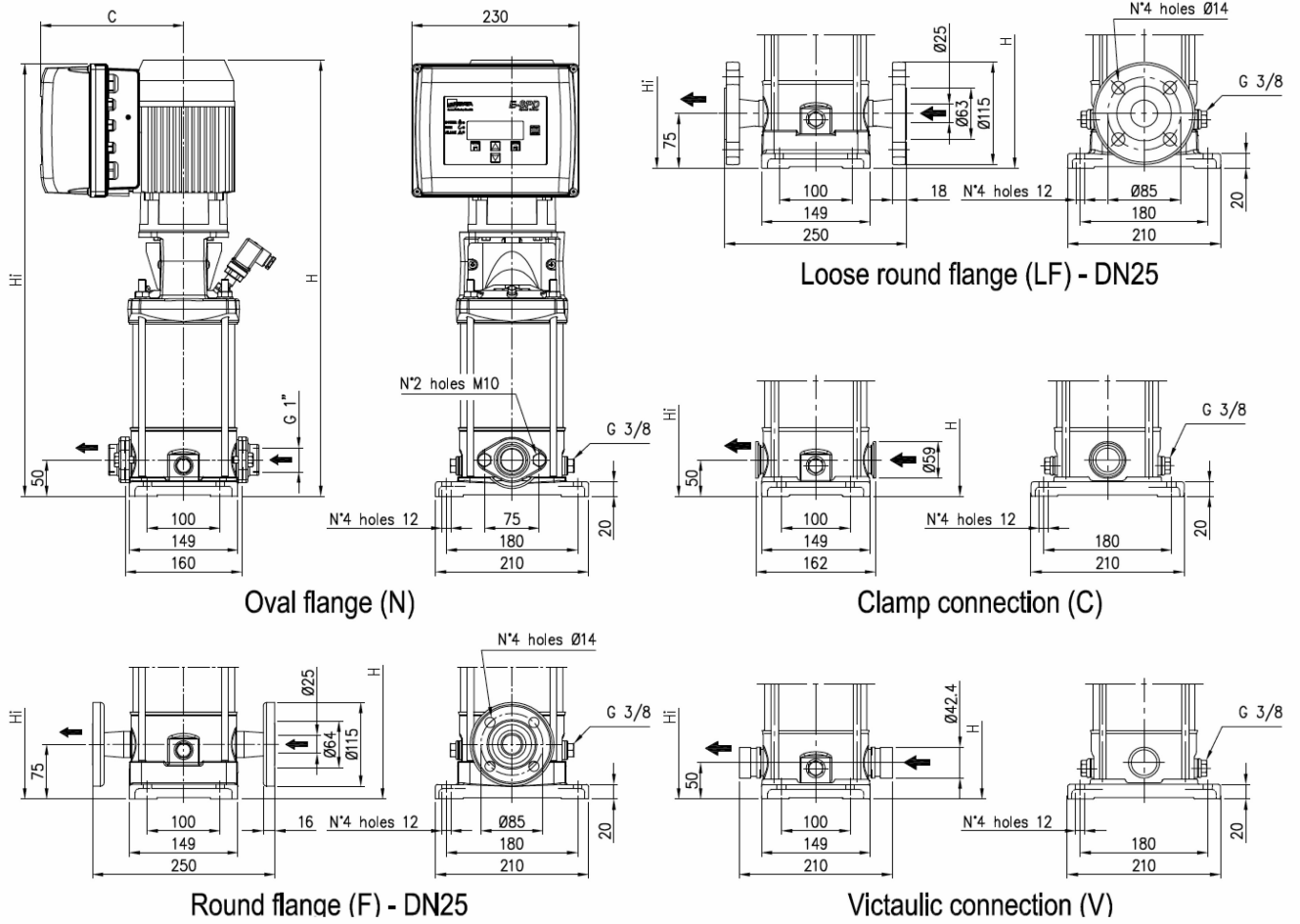

Dimensions in		mm						
1	C	191						
2	H	787						
3	Hi	782						
4								
5								
6								
7								
8								
9								
10								
11								
12								
13								
14								
15								

# (1/2) Construction

Pump name EVMS-K1 16N5Q1BEG/0.75 TT

Customer	Date 2024-06-14	Company
Contact	Item no.	Issued by
Phone	Project	Phone
E-mail	Project ID Proiect redenumit 2024-06-14 09:53:20	E-mail

EVMS-K

EVMSL-K

EVMSG-K



POS	PART NAME	MATERIAL	QUANTITY
1	EVMSG-K PUMP	EN-GJL-250 (CAST IRON)	1
	EVMS-K PUMP	EN 1.4301 (AISI 304)	1
	EVMSL-K PUMP	EN 1.4404 (AISI 316L)	1
2	ELETRIC MOTOR	ALUMINIUM	1
3	INVERTER	ALUMINIUM-PLASTIC	1
4	PRESSURE TRANSDUCER	EN 1.4301 (AISI 304)	1

(2/2)

# Construction

Pump name EVMS-K1 16N5Q1BEG/0.75 TT

Customer	Date	2024-06-14	Company
Contact	Item no.		Issued by
Phone	Project		Phone
E-mail	Project ID	Proiect redenumit 2024-06-14 09:53:20	E-mail

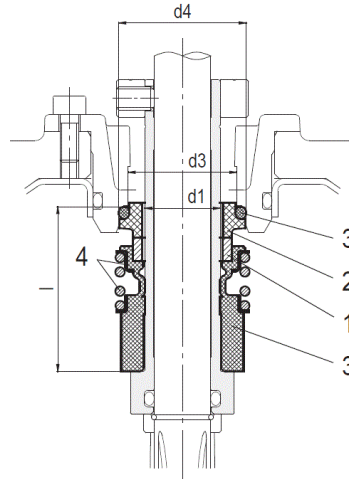

up to 16 bar  
Cartridge Unbalanced type

Type key	Availability	Max operating pressure	Max operating temperature	Shaft seal type		Shaft seal material									
				Cartridge		1		2		3		4		5	
				Type	Code	Rotating part	Code	Stationary part	Code	Elastomers	Code	Compression spring	Collar	Code	
Q1BEG	●	16 bar	- 30°C to + 120°C	Unbalanced	(-)	SIC	(Q1)	Carbon	(B)	EPDM	(E)	AISI 316	(G)		

Pump model	Shaft seal type		Max operating pressure	d1 [mm]	d2 [mm]	d3 [mm]	d4 [mm]	l [mm]
EVMS 1/3/5	Cartridge	Unbalanced	16 bar	16	-	23	27	35
		Balanced	25 bar		20			42.5
EVMS 10/15/20	Cartridge	Unbalanced	16 bar	20	-	29	35	37.5
		Balanced	25 bar		24			45