

Technical Data

Pump Name

EVMS20 6.N6Q1BEGE/11

Customer	Date	2024-07-01	Company
Contact	Item no.		Issued by
Phone	Project		Phone
E-mail	Project ID	Proiect redenumit 2024-07-01 19:11:46	E-mail

Requested data

1	Pump type	VERTICAL MULTISTAGE PUMP	Fluid	Water
2	Number of pumps / Reserve	1 / 0	Liquid temperature	°C
3	Flow	m³/h	Kin. viscosity	mm²/s
4	Head	m	Vapour pressure	bar
5	Geodetic head	m	PH value	
6	Inlet pressure (pin)	bar	Density	kg/m³
7	Available system NPSH		Solids	Weight %
8	Ambient temperature	°C		

Pump

9	Pump Name	EVMS20 6.N6Q1BEGE/11	Frequency	Hz	60	
10	Design	VERTICAL MULTISTAGE PUMP	Installation type		Oval flange (STANDARD)	
11	Manufacturer	EBARA	Impeller Diameter	Max.	mm	
12	Speed	rpm		3515	Designed	mm
13	No. of Stage	6		Min.	mm	113
14	Connection	Suction side	Flow	Operating	m³/h	
15	Connection	Discharge side		Max-	m³/h	30
16	Max Working Pressure	bar		16	Min-	m³/h
17	Shut-off head	bar	14.65	Head	Operating	m
18	Total weight	kg	See the table of "Dimensions".		- (Qmax.)	m
19	Shaft power	kW			- (Qmin.)	m
20			Max. Shaft Power at max. impeller	kW	10.98	
21	Required pump NPSH	m	Efficiency	%		

Materials

22	Impeller	AISI 304		
23	Intermediate casing	AISI 304		
24	Bottom casing	AISI 304		
25	Shaft	AISI 304		
26	O-ring	EPDM		
27				

Motor

28	Manufacturer	ETM	Insulation class	F	
29	Type	TEFC_EVMS20 6/116_380_Three Phase	Phases	3~	
30	Specific design	IE3 / 60 Hz / Pole pairs 1	Frame size	160	
31	Rated power	kW	11	Weight	kg
32	Number of poles	2	Electric voltage	V	380
33	Speed	rpm	3535	Electric current	A
34	Degree of protection	IP 55			
35					

Remarks

Performance Curve

Pump Name

EVMS20 6.N6Q1BEGE/11

Customer	Date	2024-07-01	Company
Contact	Item no.		Issued by
Phone	Project		Phone
E-mail	Project ID	Project redenumit 2024-07-01 19:11:46	E-mail

Requested data

1	Flow	m³/h	
2	Head	m	
3	Geodetic head	m	

Pump

Operating flow	m³/h		Frequency	Hz	60
Operating head	m		Number of poles		2
Impeller diameter designed	mm	113	Speed	rpm	3515

Test standard: ISO 9906:2012 - Grade3B

Water; 20°C; 998.3kg/m³; 1mm²/s

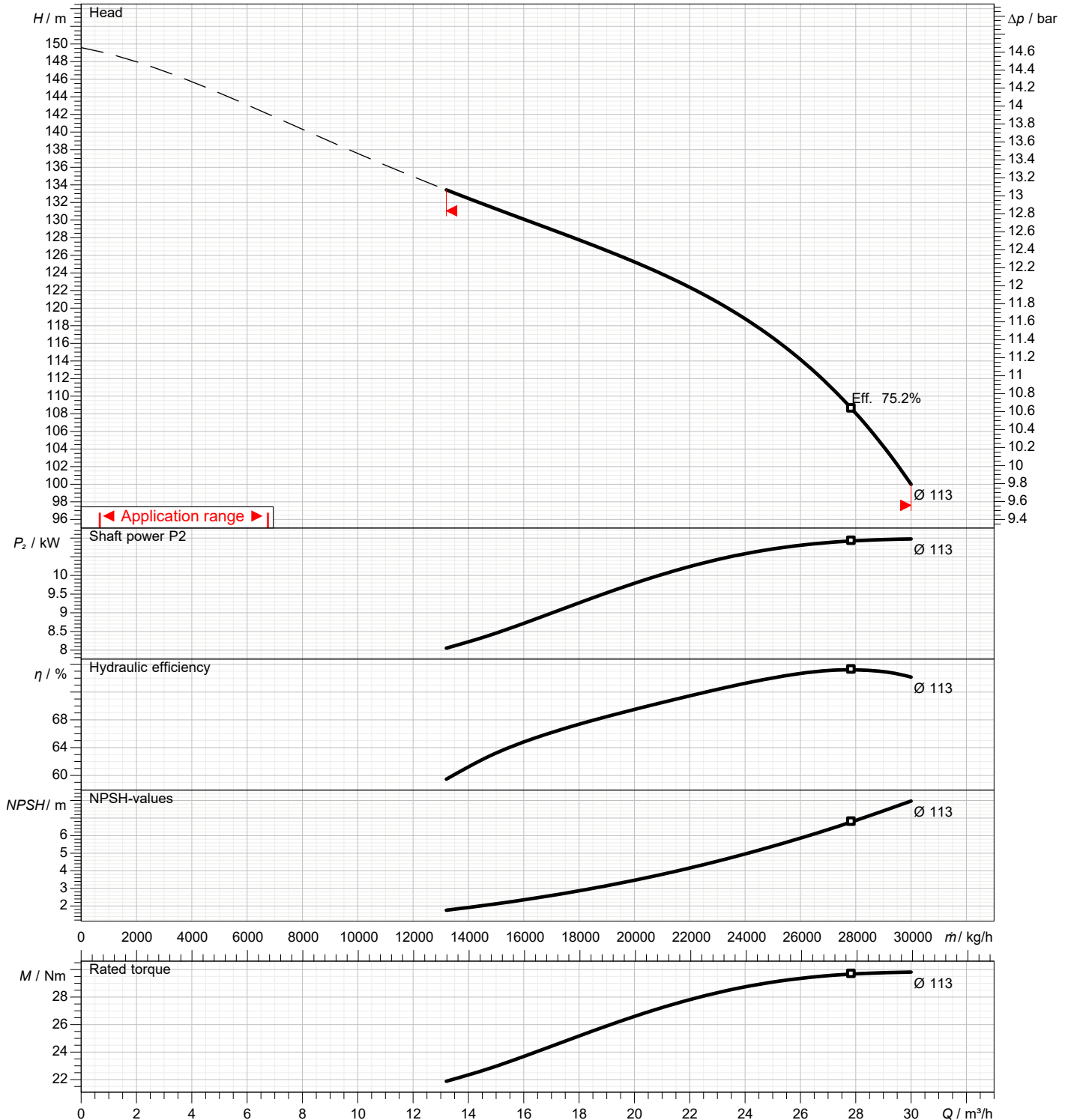

Dimensions

Pump name EVMS20 6.N6Q1BEGE/11

Customer	Date 2024-07-01	Company
Contact	Item no.	Issued by
Phone	Project	Phone
E-mail	Project ID Proiect redenumit 2024-07-01 19:11:46	E-mail

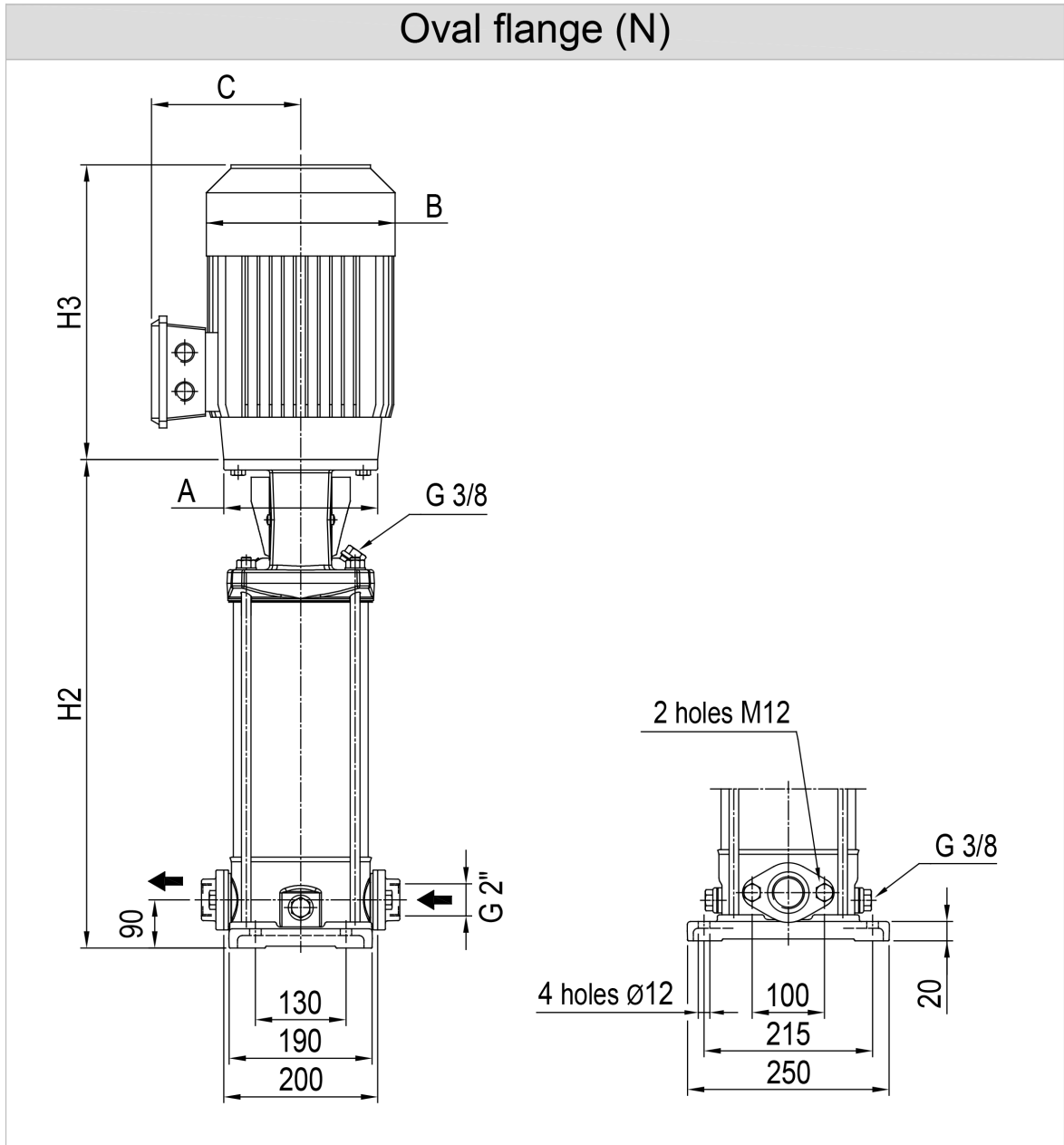

Dimensions in		mm						
1	A	Dia 350						
2	B	311						
3	C	240						
4	H2	684						
5	H3	495						
6	Weight P&M (kg)	98.9						
7								
8								
9								
10								
11								
12								
13								
14								
15								

(1/4)

Construction

Pump name EVMS20 6.N6Q1BEGE/11

Customer	Date 2024-07-01	Company
Contact	Item no.	Issued by
Phone	Project	Phone
E-mail	Project ID Proiect redenumit 2024-07-01 19:11:46	E-mail

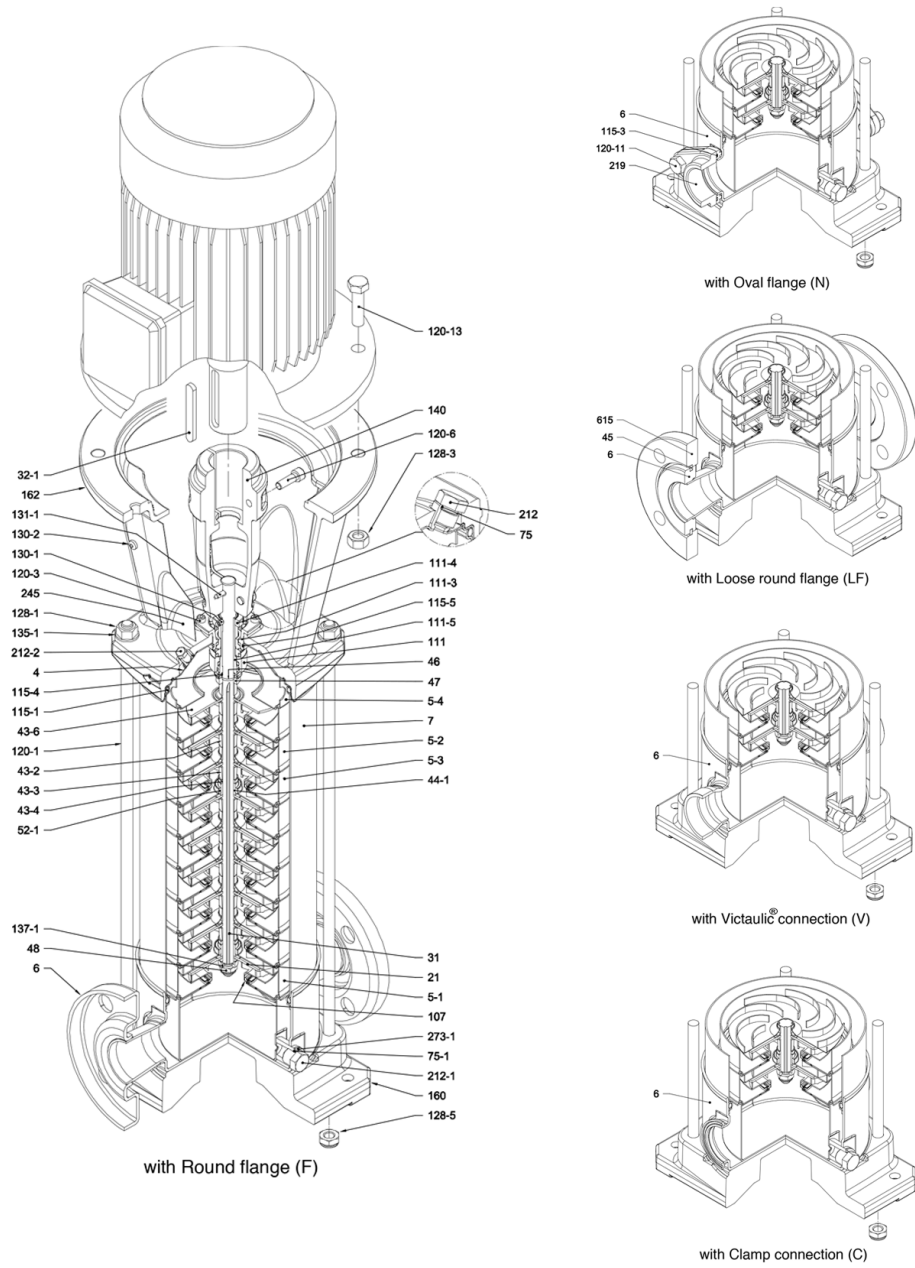

(2/4)

Construction

Pump name EVMS20 6.N6Q1BEGE/11

Customer	Date	2024-07-01	Company
Contact	Item no.		Issued by
Phone	Project		Phone
E-mail	Project ID	Proiect redenumit 2024-07-01 19:11:46	E-mail

N°	PART NAME	MATERIAL		DIMENSIONS	STANDARD
		EVMS	EVMSL		
4	Casing cover	EN 1.4301 (AISI 304)	EN 1.4404 (AISI 316L)		
5-1	Suction casing	EN 1.4301 (AISI 304)	EN 1.4404 (AISI 316L)		
5-2	Intermediate casing	EN 1.4301 (AISI 304)	EN 1.4404 (AISI 316L)		
5-3	Intermediate casing with bearing	EN 1.4301 (AISI 304)	EN 1.4404 (AISI 316L)		
5-4	Discharge casing	EN 1.4301 (AISI 304)	EN 1.4404 (AISI 316L)		
6	Bottom casing	EN 1.4301 (AISI 304)	EN 1.4404 (AISI 316L)		
7	Outer casing	EN 1.4301 (AISI 304)	EN 1.4404 (AISI 316L)		
21	Impeller	EN 1.4301 (AISI 304)	EN 1.4404 (AISI 316L)		
31	Shaft	EN 1.4301 (AISI 304) - EN 1.4462 (AISI 329A)	EN 1.4404 (AISI 316L) - EN 1.4462 (AISI 329A)		
32-1	Adjuster key	EN 1.4301 (AISI 304)			
43-2	Shaft sleeve (intermediate)	EN 1.4301 (AISI 304)	EN 1.4404 (AISI 316L)		
43-3	Shaft sleeve (bearing)	EN 1.4301 (AISI 304)	EN 1.4404 (AISI 316L)		
43-4	Shaft sleeve (adjustment)	EN 1.4301 (AISI 304)	EN 1.4404 (AISI 316L)		
43-6	Washer	EN 1.4404 (AISI 316L)		Ø26x2.5	
44-1	Shaft sleeve bearing	Tungsten carbide			
45	Flange holder	EN 1.4301 (AISI 304)			
46	Ring (mechanical seal)	EN 1.4404 (AISI 316L)			
47	Ring holder	EN 1.4301 (AISI 304)	EN 1.4404 (AISI 316L)		
48	Impeller nut	EN 1.4301 (AISI 304) with inox insert	EN 1.4401 (AISI 316) with inox insert	M10	
52-1	Sleeve bearing	Tungsten carbide			
75	O-Ring (priming plug)	EPDM / FPM *		Ø12.37x2.62	OR 3050
75-1	O-Ring (drainage plug)	EPDM / FPM *			
107	Liner ring	EN 1.4301 (AISI 304) + PPS	EN 1.4404 (AISI 316L) + PPS		
111	Mechanical seal	- - - **			
111-3	Mechanical seal seat	EN 1.4308 (ASTM CF8)	EN 1.4408 (ASTM CF8M)		
111-4	Seal holder	EN 1.4301 (AISI 304)			
111-5	Mechanical seal cartridge sleeve	EN 1.4301 (AISI 304)	EN 1.4404 (AISI 316L)		
115-1	O-Ring (outer casing)	EPDM / FPM *		Ø164.46x5.34	OR 6945
115-3	O-Ring	EPDM / FPM *			
115-4	O-Ring (cartridge sleeve)	EPDM / FPM *		Ø15.88x2.62	OR 4093
115-5	O-Ring (seal flange)	EPDM / FPM *		Ø37.77x2.62	OR 4175
120-1	Tie-rod	EN 1.4057 (AISI 431)		M12	
120-3	Screw (seal flange)	A2-70		M5x12	ISO 4762
120-6	Screw (pump coupling)	up to 4.0 kW	Galvanized steel	M6x25	ISO 4762
		from 5.5 kW to 7.5 kW		M8x20	ISO 4762
		above 11 kW		M10x30	ISO 4762
120-11	Screw (counterflange)	A2-70			
120-13	Screw for motor	MEC 90-100-112	Galvanized steel 8.8 strength class ISO 898/1	M8x20	ISO 4017
		MEC 132		M12x40	ISO 4017
		MEC 160		M16x50	ISO 4017
128-1	Nut (tie rod)	A2-70		M12	ISO 4032
128-3	Nut (motor)	MEC 132	Galvanized steel	M12	ISO 4032
		MEC 160		M16	ISO 4032
128-5	Nut (tie rod)	A2-70		M12	UNI 7474
128-6	Nut (aluminium coupling)	MEC 71-80-90-100-112	Galvanized steel	M6	ISO 4032
130-1	Set screw	EN 1.4301 (AISI 304)		M5x8	ISO 4026
130-2	Screw for coupling guard	A2-70		M5x6	UNI 7687
131-1	Pin for shaft	Carbon Steel		Ø5x35	ISO 2338
135-1	Washer (tie rod)	EN 1.4301 (AISI 304)		Ø13x24x2.5	ISO 7089
135-6	Washer (aluminium coupling)	up to 4.0 kW	Carbon Steel	Ø6	
137-1	Impeller spacer	EN 1.4301 (AISI 304)	EN 1.4404 (AISI 316L)		
140	Coupling	up to 4.0 kW	Die cast Aluminium EN AB-AISI11 Cu2 (Fe)		
		above 5.5 kW	Cast iron		
160	Base	Die cast Aluminium EN AB-AISI11 Cu2 (Fe)			
162	Motor bracket	Cast iron EN-GJL-250			
212	Priming plug	EN 1.4301 (AISI 304)	EN 1.4404 (AISI 316L)	G 3/8	
212-1	Drainage plug	EN 1.4301 (AISI 304)	EN 1.4404 (AISI 316L)	G 3/8	
212-2	Venting plug	EN 1.4404 (AISI 316L)			
219	Counter flange	flange type: N	EN 1.4308 (ASTM CF8)	EN 1.4408 (ASTM CF8M)	
		flange type: LF-F-V-C	EN 1.4301 (AISI 304)	EN 1.4404 (AISI 316L)	
245	Coupling guard	EN 1.4301 (AISI 304)			
273-1	Washer (drainage plug)	EN 1.4301 (AISI 304)	EN 1.4404 (AISI 316L)		
615	Flange	Carbon Steel			

* EPDM (standard)
FPM (option)

** see CONSTRUCTION 4/4

(3/4)

Construction

Pump name EVMS20 6.N6Q1BEGE/11

Customer	Date	2024-07-01	Company
Contact	Item no.		Issued by
Phone	Project		Phone
E-mail	Project ID	Proiect redenumit 2024-07-01 19:11:46	E-mail

Pump Type	N°																															
	4	5-1	5-2	5-3	5-4	6	7	21	31***	32-1	43-2	43-3	43-4	43-6	44-1	45**	46	47	48	52-1	75	75-1	107	111	111-3	111-4	111-5	115-1	115-3*	115-4	115-5	
EVMS(L)20 1/1.5	1	1	/	1	1	1	1	1	1	1	/	2	1	1	1	4	2	1	1	1	1	2	1	1	1	1	1	2	2	1	1	1
EVMS(L)20 2/3.0	1	1	/	1	1	1	1	2	1	1	/	2	1	/	1	4	2	1	1	1	1	2	2	1	1	1	1	2	2	1	1	1
EVMS(L)20 3/4.0	1	1	1	1	1	1	1	3	1	1	1	2	1	/	1	4	2	1	1	1	1	2	3	1	1	1	1	2	2	1	1	1
EVMS(L)20 4/5.5	1	1	2	1	1	1	1	4	1	1	2	2	1	/	1	4	2	1	1	1	1	2	4	1	1	1	1	2	2	1	1	1
EVMS(L)20 5/7.5	1	1	3	1	1	1	1	5	1	1	3	2	1	/	1	4	2	1	1	1	1	2	5	1	1	1	1	2	2	1	1	1
EVMS(L)20 6/7.5	1	1	4	1	1	1	1	6	1	1	4	2	1	/	1	4	2	1	1	1	1	2	6	1	1	1	1	2	2	1	1	1
EVMS(L)20 7/11	1	1	4	2	1	1	1	7	1	1	4	3	2	/	2	4	2	1	1	2	1	2	7	1	1	1	1	2	2	1	1	1
EVMS(L)20 8/11	1	1	5	2	1	1	1	8	1	1	5	3	2	/	2	4	2	1	1	2	1	2	8	1	1	1	1	2	2	1	1	1
EVMS(L)20 9/11	1	1	6	2	1	1	1	9	1	1	6	3	2	/	2	4	2	1	1	2	1	2	9	1	1	1	1	2	2	1	1	1
EVMS(L)20 10/11	1	1	7	2	1	1	1	10	1	1	7	3	2	/	2	4	2	1	1	2	1	2	10	1	1	1	1	2	/	1	1	1
EVMS(L)20 11/15	1	1	8	2	1	1	1	11	1	1	8	3	2	/	2	4	2	1	1	2	1	2	11	1	1	1	1	2	/	1	1	1
EVMS(L)20 12/15	1	1	9	2	1	1	1	12	1	1	9	3	2	/	2	4	2	1	1	2	1	2	12	1	1	1	1	2	/	1	1	1
EVMS(L)20 13/15	1	1	10	2	1	1	1	13	1	1	10	3	2	/	2	4	2	1	1	2	1	2	13	1	1	1	1	2	/	1	1	1
EVMS(L)20 14/18.5	1	1	11	2	1	1	1	14	1	1	11	3	2	/	2	4	2	1	1	2	1	2	14	1	1	1	1	2	/	1	1	1
EVMS(L)20 15/18.5	1	1	12	2	1	1	1	15	1	1	12	3	2	/	2	4	2	1	1	2	1	2	15	1	1	1	1	2	/	1	1	1
EVMS(L)20 16/18.5	1	1	13	2	1	1	1	16	1	1	13	3	2	/	2	4	2	1	1	2	1	2	16	1	1	1	1	2	/	1	1	1

Pump Type	N°																								
	120-1	120-3	120-6	120-11*	120-13	128-1	128-3	128-5	128-6	130-1	130-2	131-1	135-1	135-6	137-1	140	160	162	212	212-1	212-2	219*	245	273-1	615**
EVMS(L)20 1/1.5	4	4	4	4	4	4	/	4	4	3	4	1	4	4	1	2	1	1	1	2	1	2	2	2	2
EVMS(L)20 2/3.0	4	4	4	4	4	4	/	4	4	3	4	1	4	4	1	2	1	1	1	2	1	2	2	2	2
EVMS(L)20 3/4.0	4	4	4	4	4	4	/	4	4	3	4	1	4	4	1	2	1	1	1	2	1	2	2	2	2
EVMS(L)20 4/5.5	4	4	4	4	4	4	4	4	/	3	4	1	4	/	1	2	1	1	1	2	1	2	2	2	2
EVMS(L)20 5/7.5	4	4	4	4	4	4	4	4	/	3	4	1	4	/	1	2	1	1	1	2	1	2	2	2	2
EVMS(L)20 6/7.5	4	4	4	4	4	4	4	4	/	3	4	1	4	/	1	2	1	1	1	2	1	2	2	2	2
EVMS(L)20 7/11	4	4	4	4	4	4	4	4	/	3	4	1	4	/	1	2	1	1	1	2	1	2	2	2	2
EVMS(L)20 8/11	4	4	4	4	4	4	4	4	/	3	4	1	4	/	1	2	1	1	1	2	1	2	2	2	2
EVMS(L)20 9/11	4	4	4	4	4	4	4	4	/	3	4	1	4	/	1	2	1	1	1	2	1	2	2	2	2
EVMS(L)20 10/11	4	4	4	/	4	4	4	4	/	3	4	1	4	/	1	2	1	1	1	2	1	/	2	2	2
EVMS(L)20 11/15	4	4	4	/	4	4	4	4	/	3	4	1	4	/	1	2	1	1	1	2	1	/	2	2	2
EVMS(L)20 12/15	4	4	4	/	4	4	4	4	/	3	4	1	4	/	1	2	1	1	1	2	1	/	2	2	2
EVMS(L)20 13/15	4	4	4	/	4	4	4	4	/	3	4	1	4	/	1	2	1	1	1	2	1	/	2	2	2
EVMS(L)20 14/18.5	4	4	4	/	4	4	4	4	/	3	4	1	4	/	1	2	1	1	1	2	1	/	2	2	2
EVMS(L)20 15/18.5	4	4	4	/	4	4	4	4	/	3	4	1	4	/	1	2	1	1	1	2	1	/	2	2	2
EVMS(L)20 16/18.5	4	4	4	/	4	4	4	4	/	3	4	1	4	/	1	2	1	1	1	2	1	/	2	2	2

* only for Oval flange (N)

** only for Loose round flange (LF)

*** shaft in EN 1.4462 (AISI 329A)

128-6 / 135-6: with Aluminium coupling

(4/4)

Construction

Pump name EVMS20 6.N6Q1BEGE/11

Customer	Date 2024-07-01	Company
Contact	Item no.	Issued by
Phone	Project	Phone
E-mail	Project ID Proiect redenumit 2024-07-01 19:11:46	E-mail

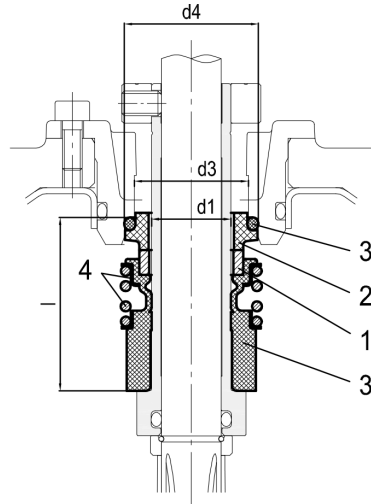

● : Standard

Pump model	Max operating temperature	Shaft seal type		Shaft seal material								Type key		
		Cartridge		1		2		3		4			5	
		Unbalanced	Balanced	Rotating Part	Code	Stationary Part	Code	Elastomers	Code	Compression spring	Collar		Code	
up to 16 bar	- 30°C to + 120°C	●		SiC	(Q1)	Carbon	(B)	EPDM	(E)	AISI 316		(G)	Q1BEG	

Max operating pressure	d1	d2	d3	d4	l
	[mm]	[mm]	[mm]	[mm]	[mm]
16 bar	20	-	29	35	37.5