

Technical data

Pump name EVMS32 11-2LF5HQ1BEG E/18.5

Customer	Date 2024-06-14	Company
Contact	Item no.	Issued by
Phone	Project	Phone
E-mail	Project ID Proiect redenumit 2024-06-14 09:53:	E-mail

Requested data

1	Pump type	VERTICAL MULTISTAGE PUMP	Fluid	Water
2	Number of pumps / Reserve	1 / 0	Liquid temperature °C	20
3	Flow m ³ /h		Kin. viscosity mm ² /s	1.005
4	Head m		Vapour pressure bar	0.0234
5	Geodetic head m		PH value	
6	Inlet pressure (pin) bar	0	Density kg/m ³	998.3
7	Available system NPSH		Solids Weight %	0
8	Ambient temperature °C	20		

Pump

9	Pump name	EVMS32 11-2LF5HQ1BEG E/18.5	Frequency Hz	50	
10	Design	VERTICAL MULTISTAGE PUMP	Installation type	Loose flange	
11	Manufacturer	EBARA	Impeller Diameter	Max. mm	-
12	Speed rpm	2950		Designed mm	117,6 (No.9) / 108 (No.2)
13	No. of Stage	11		Min. mm	-
14	Connection Suction side		Flow	Operating m ³ /h	
15	Connection Discharge side			Max- m ³ /h	42
16	Max Working Pressure bar	25		Min- m ³ /h	12
17	Shut-off head bar	22.78	Head	Operating m	
18	Total weight kg	See the table of "Dimensions".		- (Qmax.) m	112.2
19	Shaft power kW			- (Qmin.) m	218.4
20			Max. Shaft Power at max. impeller kW	18.50	
21	Required pump NPSH m		Efficiency %		

Materials

22	Impeller	AISI 304		
23	Intermediate casing	AISI 304		
24	Bottom casing	EN 1.4308 (ASTM CF8)		
25	Casing cover	AISI 304		
26	Shaft	AISI 304		
27	O-ring	EPDM		

Motor

28	Manufacturer	ATB	Insulation class	F
29	Type	TEFC_EVMS32 11-2/18.5_400_Three Phase	Phases	3~
30	Specific design	IE3 / 50 Hz / Pole pairs 1	Frame size	160
31	Rated power kW	18.5	Weight kg	109
32	Number of poles	2	Electric voltage V	400
33	Speed rpm	2955	Electric current A	32.8
34	Degree of protection	IP56		
35				

Remarks

Performance curve

Pump name **EVMS32 11-2LF5HQ1BEG E/18.5**

Customer	Date	2024-06-14	Company
Contact	Item no.		Issued by
Phone	Project		Phone
E-mail	Project ID	Project redenumit 2024-06-14 09:53:	E-mail

Requested data

1	Flow	m ³ /h	
2	Head	m	
3	Geodetic head	m	

Pump

Operating flow	m ³ /h	Impeller Diameter Designed	mm	117,6 (No.9) / 108 (No.2)
Operating head	m	Frequency	Hz	50
		Speed	rpm	2950

Test standard: ISO 9906:2012 - Grade3B

Water; 20°C; 998.3kg/m³; 1mm²/s

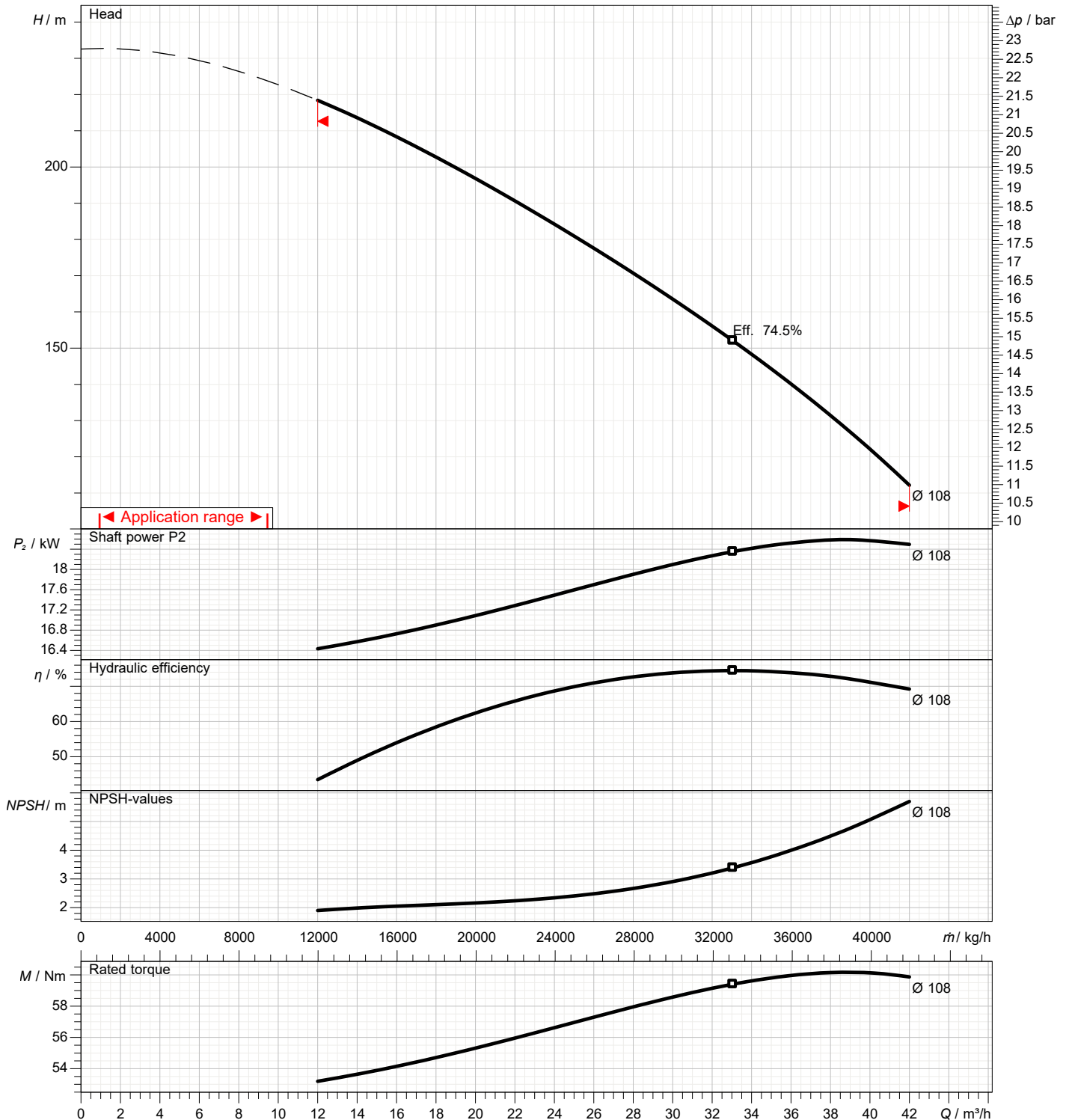

Dimensions

Pump Name EVMS32 11-2LF5HQ1BEG E/18.5

Customer	Date	2024-06-14	Company
Contact	Item no.		Issued by
Phone	Project		Phone
E-mail	Project ID	Proiect redenumit 2024-06-14 09:53:20	E-mail

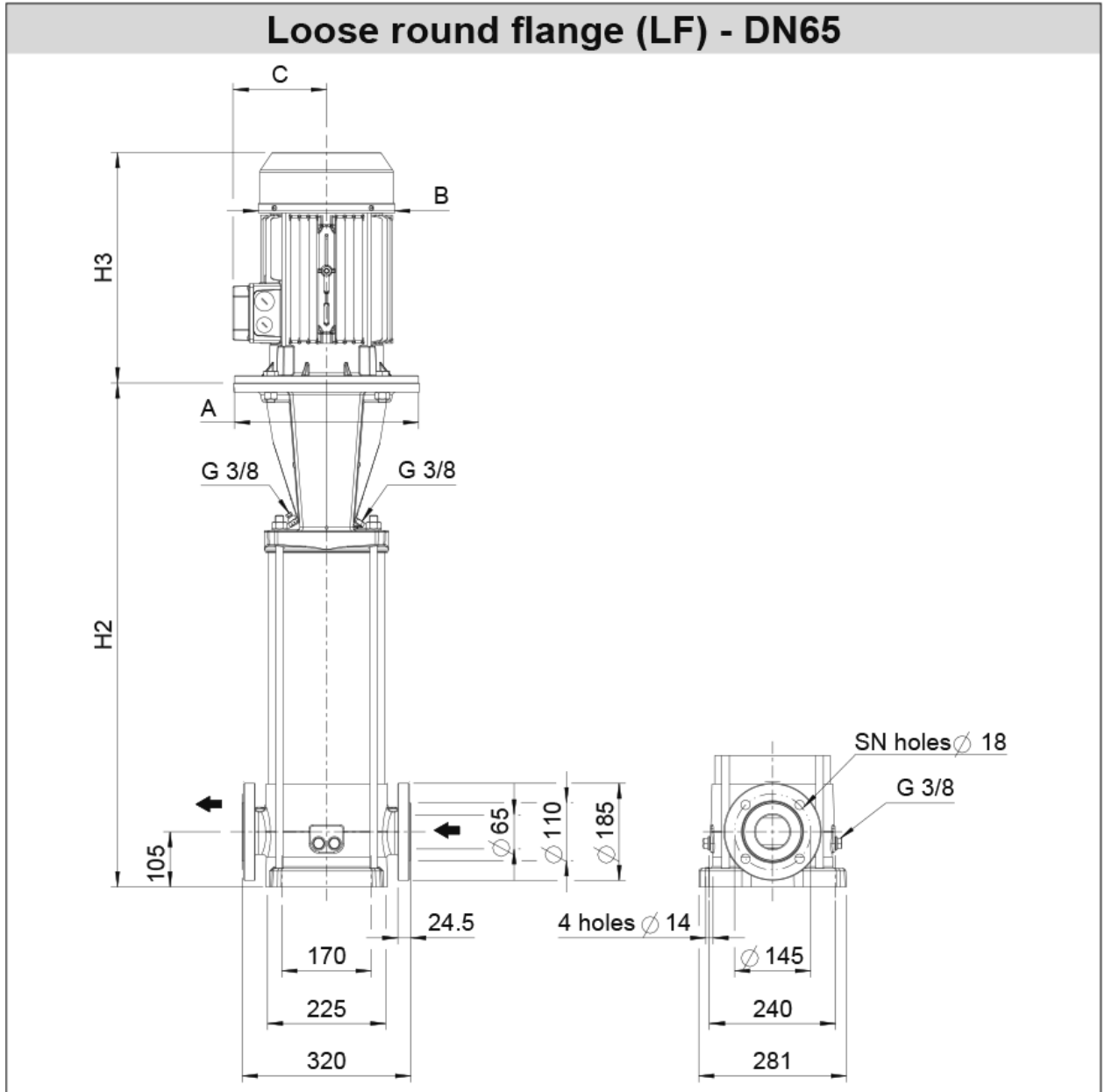

Dimensions in		mm						
1	A	Dia350						
2	B	311						
3	C	240						
4	H2	1295						
5	H2+H3	1790						
6	SN	8						
7	Weight P&M (kg)	209.8						
8								
9								
10								
11								
12								
13								
14								
15								

Customer	Date 2024-06-14	Company
Contact	Item no.	Issued by
Phone	Project	Phone
E-mail	Project ID Proiect redenumit 2024-06-14 09:53:20	E-mail

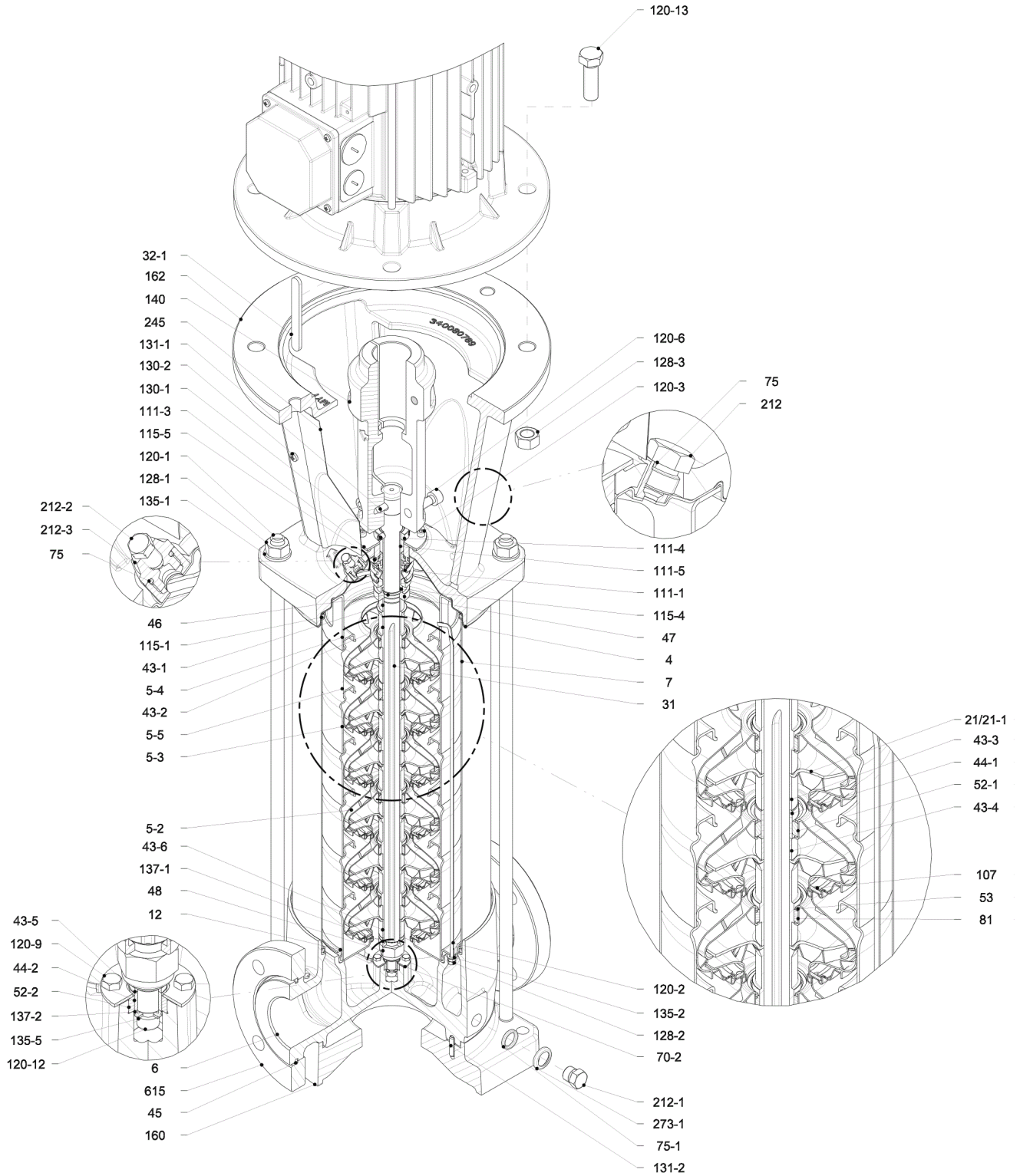

(2/3)

Construction

Pump Name EVMS32 11-2LF5HQ1BEG E/18.5

Customer	Date	2024-06-14	Company
Contact	Item no.		Issued by
Phone	Project		Phone
E-mail	Project ID	Proiect redenumit 2024-06-14 09:53:20	E-mail

N°	PART NAME	MATERIAL		DIMENSIONS	STANDARD	QTY
		EVMS	EVMSL			
4	Casing cover	EN 1.4301 (AISI 304)	EN 1.4404 (AISI 316L)			1
5-2	Intermediate casing	EN 1.4301 (AISI 304)	EN 1.4404 (AISI 316L)			8
5-3	Intermediate casing with bearing	EN 1.4301 (AISI 304)	EN 1.4404 (AISI 316L)			2
5-4	Discharge casing	EN 1.4301 (AISI 304)	EN 1.4404 (AISI 316L)			1
5-5	Top intermediate casing	EN 1.4301 (AISI 304)	EN 1.4404 (AISI 316L)			1
6	Bottom casing	EN 1.4308 (ASTM CF8)	EN 1.4408 (ASTM CF8M)			1
7	Outer casing	EN 1.4301 (AISI 304)	EN 1.4404 (AISI 316L)			1
12	Suction cover	EN 1.4301 (AISI 304)	EN 1.4404 (AISI 316L)			1
21	Impeller	EN 1.4301 (AISI 304)	EN 1.4404 (AISI 316L)			9
21-1	Reduced impeller	EN 1.4301 (AISI 304)	EN 1.4404 (AISI 316L)			2
31	Shaft	EN 1.4301 (AISI 304)	EN 1.4404 (AISI 316L)			1
32-1	Adjuster key	EN 1.4301 (AISI 304)				1
43-1	Shaft sleeve (mechanical seal)	EN 1.4301 (AISI 304)	EN 1.4404 (AISI 316L)			1
43-2	Shaft sleeve (intermediate)	EN 1.4301 (AISI 304)	EN 1.4404 (AISI 316L)			9
43-3	Shaft sleeve (bearing)	EN 1.4301 (AISI 304)	EN 1.4404 (AISI 316L)			2
43-4	Shaft sleeve (adjustment)	EN 1.4301 (AISI 304)	EN 1.4404 (AISI 316L)			2
43-5	Shaft sleeve (last stage)	EN 1.4301 (AISI 304)	EN 1.4404 (AISI 316L)			1
43-6	Shaft sleeve (adjustment)	EN 1.4301 (AISI 304)	EN 1.4404 (AISI 316L)			1
44-1	Shaft sleeve bearing	Tungsten carbide				2
44-2	Shaft sleeve (bearing)	Tungsten carbide				1
45	Flange holder	EN 1.4301 (AISI 304)				4
46	Ring (mechanical seal)	EN 1.4404 (AISI 316L)				1
47	Ring holder	EN 1.4404 (AISI 316L)				1
48	Impeller nut	EN 1.4301 (AISI 304) with inox insert	EN 1.4401 (AISI 316) with inox insert			1
52-1	Sleeve bearing	Tungsten carbide				2
52-2	Sleeve bearing (bottom casing)	Tungsten carbide				1
53	Bush holder	EN 1.4301 (AISI 304)	EN 1.4404 (AISI 316L)			10
70-2	Ring for bearing sleeve	EN 1.4301 (AISI 304)	EN 1.4404 (AISI 316L)			1
75	O-Ring (priming plug)	EPDM / FPM *		Ø12.37x2.62	OR 3050	2
75-1	O-Ring (drainage plug)	EPDM / FPM *				4
81	Bush	PTFE				9
107	Liner ring	EN 1.4301 (AISI 304) + PPS	EN 1.4404 (AISI 316L) + PPS			11
111-1	Mechanical seal	- - - **				1
111-3	Mechanical seal seat	EN 1.4301 (AISI 304)	EN 1.4401 (AISI 316)			1
111-4	Seal holder	EN 1.4404 (AISI 316L)				1
111-5	Mechanical seal cartridge sleeve	EN 1.4301 (AISI 304)	EN 1.4404 (AISI 316L)			1
115-1	O-Ring (outer casing)	EPDM / FPM *		Ø240.66x5.34	OR 6945	2
115-4	O-Ring (cartridge sleeve)	EPDM / FPM *		Ø23.39x3.53	OR 4093	1
115-5	O-Ring (seal flange)	EPDM / FPM *		Ø44.04x3.53	OR 4175	1
120-1	Tie rod	EN 1.4057 (AISI 431)				4
120-2	Tie rod (stage)	EN 1.4301 (AISI 304)	EN 1.4401 (AISI 316)			2
120-3	Screw (seal flange)	A2-70		M5x12	ISO 4762	4
120-6	Screw (pump coupling) above 11 kW	Galvanized steel 8.8 strength class ISO 898/1		M10x30	ISO 4762	4
120-9	Screw (bottom casing)	A2-70		M5x8	ISO 4017	4
120-12	Screw (shaft)	A2-70		M6x16	ISO 4762	1
120-13	Screw for motor MEC 160-180	Galvanized steel 8.8 strength class ISO 898/1		M16x50	ISO 4017	4
128-1	Nut (tie rod)	A2-70		M16	ISO 4032	4
128-2	Nut (casing tie rod)	A2-70		M5	ISO 4032	4
128-3	Nut (motor) MEC 160-180-200	Galvanized steel		M16	ISO 4032	4
130-1	Set screw	EN 1.4301 (AISI 304)		M6x8	ISO 4026	3
130-2	Screw for coupling guard	A2-70		M5x6	UNI 7687	4
131-1	Pin for shaft above 5.5 kW	Carbon Steel		Ø8X50	ISO 2338	1
131-2	Elastic pin	EN 1.4301 (AISI 304)		Ø6x26	ISO 8752	1
135-1	Washer (tie rod)	EN 1.4301 (AISI 304)		Ø16	ISO 7089	4
135-2	Washer (casing tie rod)	EN 1.4301 (AISI 304)	EN 1.4404 (AISI 316)	Ø5.1	UNI 1751	2
135-5	Washer (impeller nut)	EN 1.4301 (AISI 304)	EN 1.4404 (AISI 316L)			1
137-1	Impeller spacer	EN 1.4301 (AISI 304)	EN 1.4404 (AISI 316L)			1
137-2	Shaft spacer	EN 1.4301 (AISI 304)	EN 1.4404 (AISI 316L)			1
140	Coupling from 5.5 kW to 30 kW	Cast Iron EN GJL250 EN 1561				2
160	Base	Cast Iron EN GJL200 EN 1561				1
162	Motor bracket up to 30 kW	Cast Iron EN GJS 400-15 EN 1563				1
212	Priming plug	EN 1.4301 (AISI 304)	EN 1.4404 (AISI 316L)			1
212-1	Drainage plug	EN 1.4301 (AISI 304)	EN 1.4404 (AISI 316L)			4
212-2	Venting plug	EN 1.4401 (AISI 316)				1
212-3	Priming plug	EN 1.4301 (AISI 304)	EN 1.4404 (AISI 316L)			1
245	Coupling guard	EN 1.4301 (AISI 304)				2
273-1	Washer (drainage plug)	EN 1.4301 (AISI 304)	EN 1.4404 (AISI 316L)			4
615	Loose flange	Cast Iron EN GJS 500-7 EN 1563				2

* EPDM (standard)
FPM (option)

** see CONSTRUCTION 3/3

(3/3)

Construction

Pump Name EVMS32 11-2LF5HQ1BEG E/18.5

Customer	Date	2024-06-14	Company
Contact	Item no.		Issued by
Phone	Project		Phone
E-mail	Project ID	Proiect redenumit 2024-06-14 09:53:20	E-mail

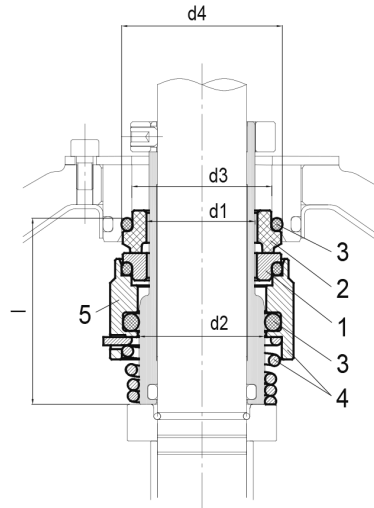

- Standard

Type key	Availability	Max operating pressure	Max operating temperature	Shaft seal type		Shaft seal material									
				Cartridge		1 Rotating part		2 Stationary part		3 Elastomers		4 Compression spring		5 Collar	
				Type	Code	Code	Code	Code	Code	Code	Code	Code	Code	Code	
HQ1BEG	●	25/35 bar	- 30°C to + 140°C	Balanced	(H)	SIC	(Q1)	Carbon	(B)	EPDM	(E)	AISI 316	(G)		

Max operating pressure	d1 [mm]	d2 [mm]	d3 [mm]	d4 [mm]	l [mm]
25 bar	28	33	37	43	50