

Technical Data

Pump Name

EVMS32 12-0LF5HQ1BEG E/22

Customer	Date	2024-06-14	Company
Contact	Item no.		Issued by
Phone	Project		Phone
E-mail	Project ID	Proiect redenumit 2024-06-14 09:53:20	E-mail

Requested data

1	Pump type	VERTICAL MULTISTAGE PUMP	Fluid	Water
2	Number of pumps / Reserve	1 / 0	Liquid temperature	°C
3	Flow	m³/h	Kin. viscosity	mm²/s
4	Head	m	Vapour pressure	bar
5	Geodetic head	m	PH value	
6	Inlet pressure (pin)	bar	Density	kg/m³
7	Available system NPSH		Solids	Weight %
8	Ambient temperature	°C		

Pump

9	Pump Name	EVMS32 12-0LF5HQ1BEG E/22	Frequency	Hz	50	
10	Design	VERTICAL MULTISTAGE PUMP	Installation type		Loose flange	
11	Manufacturer	EBARA	Impeller Diameter	Max.	mm	
12	Speed	rpm		2950	Designed	mm
13	No. of Stage			12	Min.	mm
14	Connection	Suction side	Flow	Operating	m³/h	
15	Connection	Discharge side		Max-	m³/h	
16	Max Working Pressure	bar		30	Min-	m³/h
17	Shut-off head	bar	24.96	Head	Operating	
18	Total weight	kg	See the table of "Dimensions".		- (Qmax.)	m
19	Shaft power	kW			- (Qmin.)	m
20			Max. Shaft Power at max. impeller	kW	21.60	
21	Required pump NPSH	m	Efficiency	%		

Materials

22	Impeller	AISI 304	
23	Intermediate casing	AISI 304	
24	Bottom casing	EN 1.4308 (ASTM CF8)	
25	Casing cover	AISI 304	
26	Shaft	AISI 304	
27	O-ring	EPDM	

Motor

28	Manufacturer	ATB	Insulation class	F	
29	Type	TEFC_EVMS32 12-0/22_400_Three Phase	Phases	3~	
30	Specific design	IE3 / 50 Hz / Pole pairs 1	Frame size	180	
31	Rated power	kW	22	Weight	kg
32	Number of poles		2	Electric voltage	V
33	Speed	rpm	2950	Electric current	A
34	Degree of protection		IP56		
35					

Remarks

Performance Curve

Pump Name

EVMS32 12-0LF5HQ1BEG E/22

Customer	Date	2024-06-14	Company
Contact	Item no.		Issued by
Phone	Project		Phone
E-mail	Project ID	Proiect redenumit 2024-06-14 09:53:20	E-mail

Requested data

1	Flow	m³/h	
2	Head	m	
3	Geodetic head	m	

Pump

Operating flow	m³/h		Frequency	Hz	50
Operating head	m		Number of poles		2
Impeller diameter designed	mm	118	Speed	rpm	2950

Test standard: ISO 9906:2012 - Grade3B

Water; 20°C; 998.3kg/m³; 1mm²/s

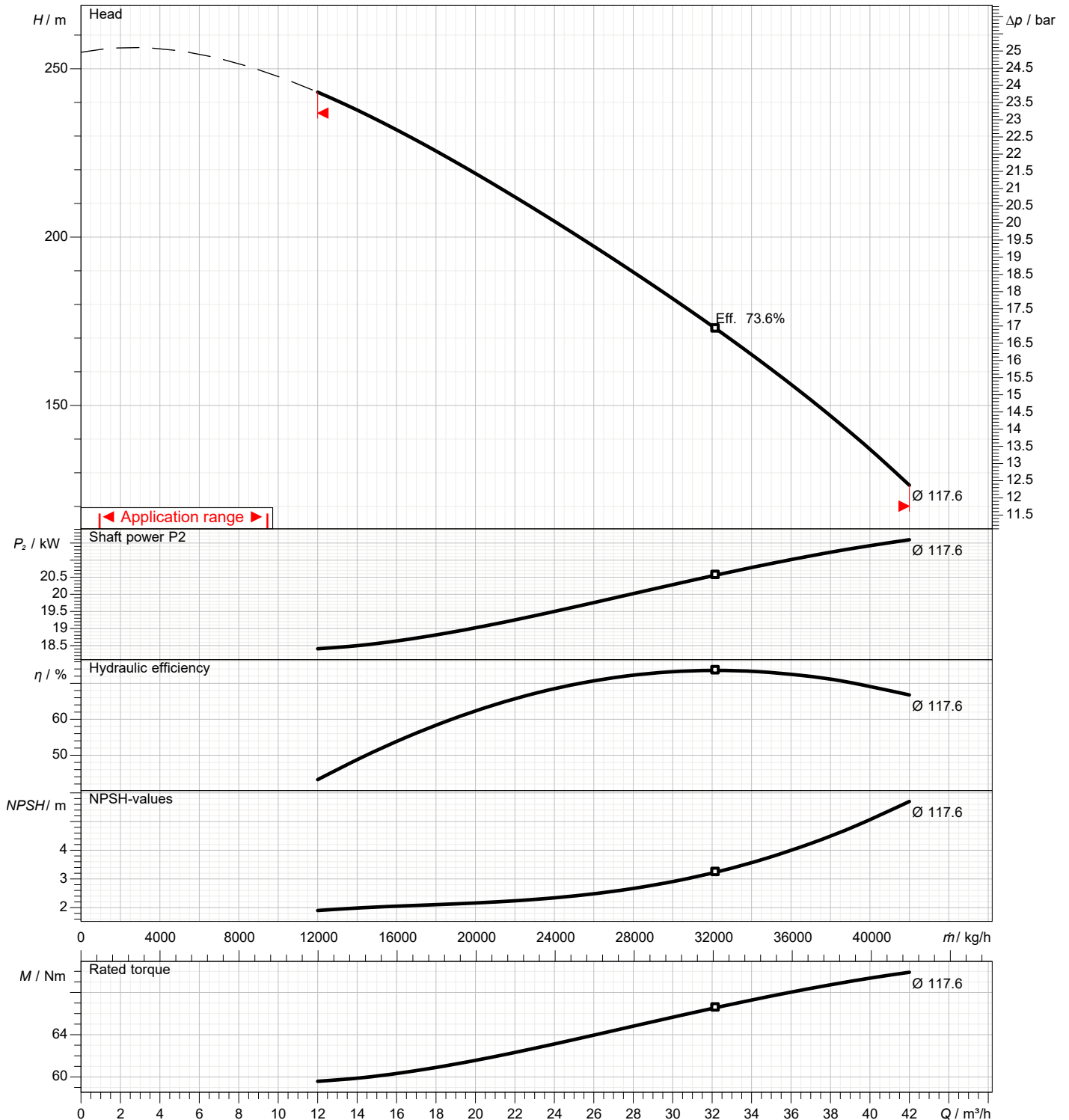

Dimensions

Pump Name EVMS32 12-0LF5HQ1BEG E/22

Customer	Date 2024-06-14	Company
Contact	Item no.	Issued by
Phone	Project	Phone
E-mail	Project ID Proiect redenumit 2024-06-14 09:53:20	E-mail

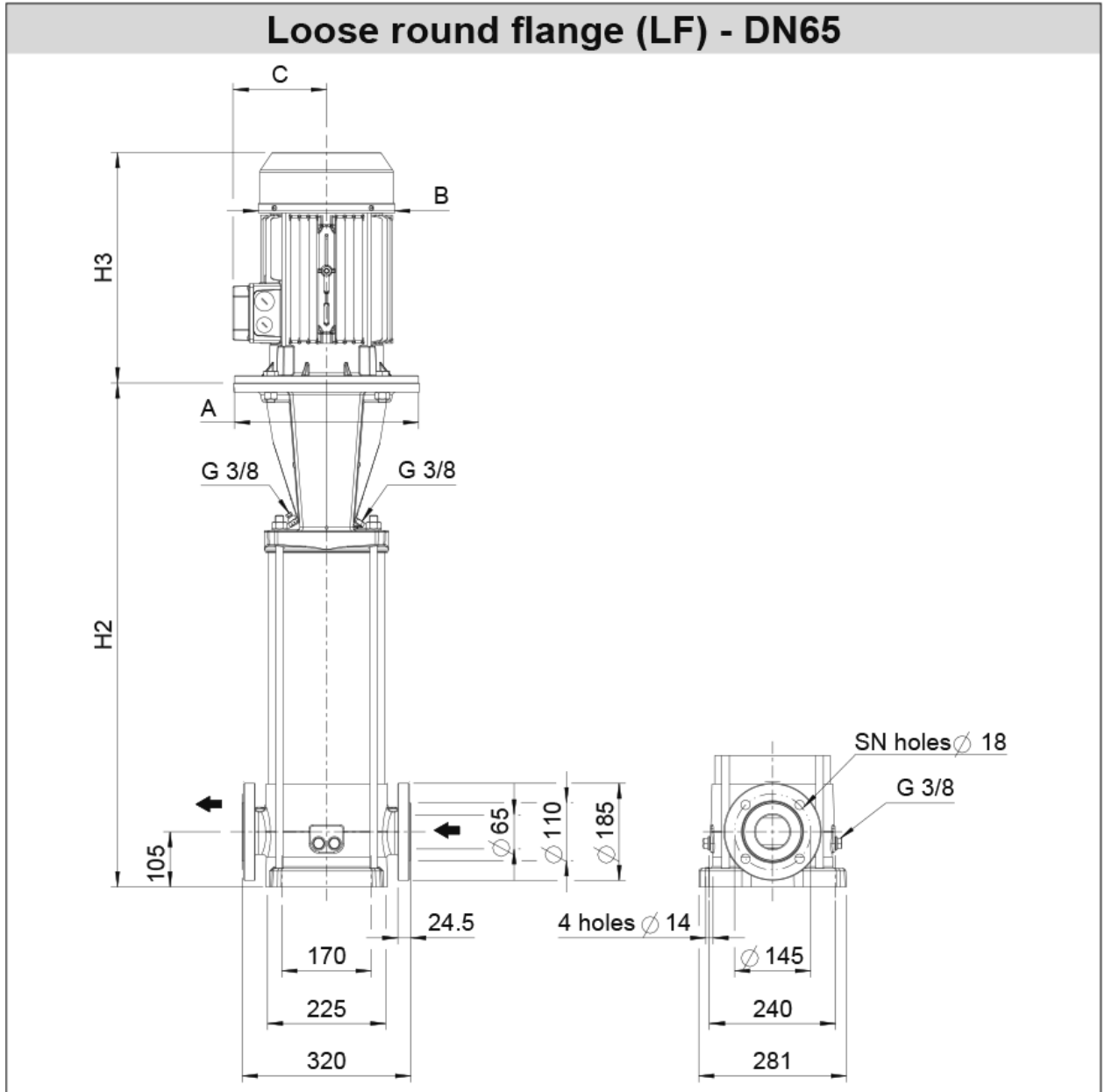

Dimensions in		mm						
1	A	Dia350						
2	B	354						
3	C	260						
4	H2	1365						
5	H2+H3	1917						
6	SN	8						
7	Weight P&M (kg)	241.8						
8								
9								
10								
11								
12								
13								
14								
15								

(1/3)

Construction

Pump Name EVMS32 12-0LF5HQ1BEG E/22

Customer	Date 2024-06-14	Company
Contact	Item no.	Issued by
Phone	Project	Phone
E-mail	Project ID Proiect redenumit 2024-06-14 09:53:20	E-mail

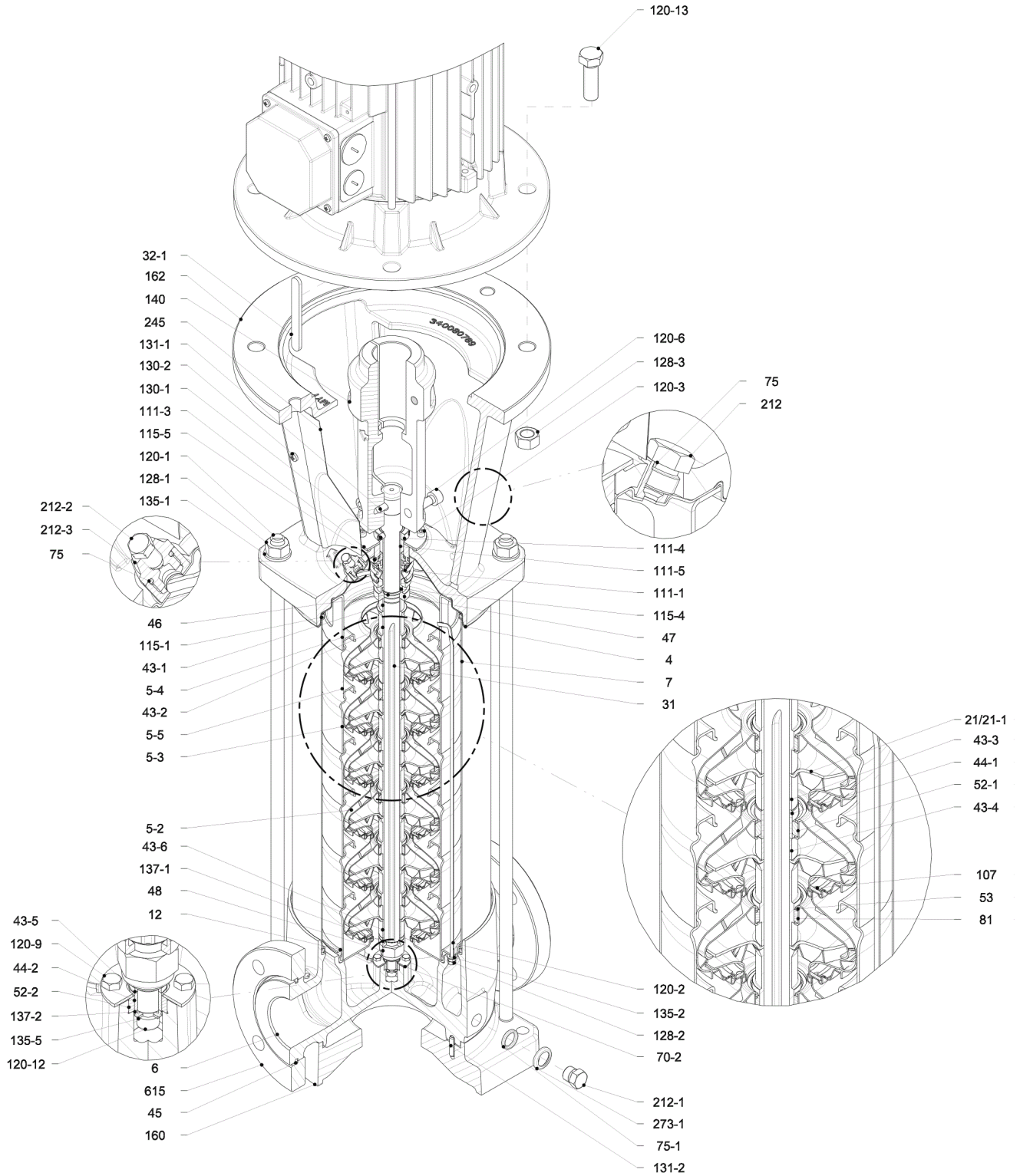

(2/3)

Construction

Pump Name EVMS32 12-0LF5HQ1BEG E/22

Customer	Date	2024-06-14	Company
Contact	Item no.		Issued by
Phone	Project		Phone
E-mail	Project ID	Proiect redenumit 2024-06-14 09:53:20	E-mail

N°	PART NAME	MATERIAL		DIMENSIONS	STANDARD	QTY
		EVMS	EVMSL			
4	Casing cover	EN 1.4301 (AISI 304)	EN 1.4404 (AISI 316L)			1
5-2	Intermediate casing	EN 1.4301 (AISI 304)	EN 1.4404 (AISI 316L)			9
5-3	Intermediate casing with bearing	EN 1.4301 (AISI 304)	EN 1.4404 (AISI 316L)			2
5-4	Discharge casing	EN 1.4301 (AISI 304)	EN 1.4404 (AISI 316L)			1
5-5	Top intermediate casing	EN 1.4301 (AISI 304)	EN 1.4404 (AISI 316L)			1
6	Bottom casing	EN 1.4308 (ASTM CF8)	EN 1.4408 (ASTM CF8M)			1
7	Outer casing	EN 1.4301 (AISI 304)	EN 1.4404 (AISI 316L)			1
12	Suction cover	EN 1.4301 (AISI 304)	EN 1.4404 (AISI 316L)			1
21	Impeller	EN 1.4301 (AISI 304)	EN 1.4404 (AISI 316L)			12
31	Shaft	EN 1.4301 (AISI 304)	EN 1.4404 (AISI 316L)			1
32-1	Adjuster key	EN 1.4301 (AISI 304)				1
43-1	Shaft sleeve (mechanical seal)	EN 1.4301 (AISI 304)	EN 1.4404 (AISI 316L)			1
43-2	Shaft sleeve (intermediate)	EN 1.4301 (AISI 304)	EN 1.4404 (AISI 316L)			10
43-3	Shaft sleeve (bearing)	EN 1.4301 (AISI 304)	EN 1.4404 (AISI 316L)			2
43-4	Shaft sleeve (adjustment)	EN 1.4301 (AISI 304)	EN 1.4404 (AISI 316L)			2
43-5	Shaft sleeve (last stage)	EN 1.4301 (AISI 304)	EN 1.4404 (AISI 316L)			1
43-6	Shaft sleeve (adjustment)	EN 1.4301 (AISI 304)	EN 1.4404 (AISI 316L)			1
44-1	Shaft sleeve bearing	Tungsten carbide				2
44-2	Shaft sleeve (bearing)	Tungsten carbide				1
45	Flange holder	EN 1.4301 (AISI 304)				4
46	Ring (mechanical seal)	EN 1.4404 (AISI 316L)				1
47	Ring holder	EN 1.4404 (AISI 316L)				1
48	Impeller nut	EN 1.4301 (AISI 304) with inox insert	EN 1.4401 (AISI 316) with inox insert			1
52-1	Sleeve bearing	Tungsten carbide				2
52-2	Sleeve bearing (bottom casing)	Tungsten carbide				1
53	Bush holder	EN 1.4301 (AISI 304)	EN 1.4404 (AISI 316L)			11
70-2	Ring for bearing sleeve	EN 1.4301 (AISI 304)	EN 1.4404 (AISI 316L)			1
75	O-Ring (priming plug)	EPDM / FPM *		Ø12.37x2.62	OR 3050	2
75-1	O-Ring (drainage plug)	EPDM / FPM *				4
81	Bush	PTFE				10
107	Liner ring	EN 1.4301 (AISI 304) + PPS	EN 1.4404 (AISI 316L) + PPS			12
111-1	Mechanical seal	- - - **				1
111-3	Mechanical seal seat	EN 1.4301 (AISI 304)	EN 1.4401 (AISI 316)			1
111-4	Seal holder	EN 1.4404 (AISI 316L)				1
111-5	Mechanical seal cartridge sleeve	EN 1.4301 (AISI 304)	EN 1.4404 (AISI 316L)			1
115-1	O-Ring (outer casing)	EPDM / FPM *		Ø240.66x5.34	OR 6945	2
115-4	O-Ring (cartridge sleeve)	EPDM / FPM *		Ø23.39x3.53	OR 4093	1
115-5	O-Ring (seal flange)	EPDM / FPM *		Ø44.04x3.53	OR 4175	1
120-1	Tie rod	EN 1.4057 (AISI 431)				4
120-2	Tie rod (stage)	EN 1.4301 (AISI 304)	EN 1.4401 (AISI 316)			2
120-3	Screw (seal flange)	A2-70		M5x12	ISO 4762	4
120-6	Screw (pump coupling)	above 11 kW	Galvanized steel 8.8 strength class ISO 898/1	M10x30	ISO 4762	4
120-9	Screw (bottom casing)	A2-70		M5x8	ISO 4017	4
120-12	Screw (shaft)	A2-70		M6x16	ISO 4762	1
120-13	Screw for motor	MEC 160-180	Galvanized steel 8.8 strength class ISO 898/1	M16x50	ISO 4017	4
128-1	Nut (tie rod)	A2-70		M16	ISO 4032	4
128-2	Nut (casing tie rod)	A2-70		M5	ISO 4032	4
128-3	Nut (motor)	MEC 160-180-200	Galvanized steel	M16	ISO 4032	4
130-1	Set screw	EN 1.4301 (AISI 304)		M6x8	ISO 4026	3
130-2	Screw for coupling guard	A2-70		M5x6	UNI 7687	4
131-1	Pin for shaft	above 5.5 kW	Carbon Steel	Ø8X50	ISO 2338	1
131-2	Elastic pin	EN 1.4301 (AISI 304)		Ø6x26	ISO 8752	1
135-1	Washer (tie rod)	EN 1.4301 (AISI 304)		Ø16	ISO 7089	4
135-2	Washer (casing tie rod)	EN 1.4301 (AISI 304)	EN 1.4404 (AISI 316)	Ø5.1	UNI 1751	2
135-5	Washer (impeller nut)	EN 1.4301 (AISI 304)	EN 1.4404 (AISI 316L)			1
137-1	Impeller spacer	EN 1.4301 (AISI 304)	EN 1.4404 (AISI 316L)			1
137-2	Shaft spacer	EN 1.4301 (AISI 304)	EN 1.4404 (AISI 316L)			1
140	Coupling	from 5.5 kW to 30 kW	Cast Iron EN GJL250 EN 1561			2
160	Base	Cast Iron EN GJL200 EN 1561				1
162	Motor bracket	up to 30 kW	Cast Iron EN GJS 400-15 EN 1563			1
212	Priming plug	EN 1.4301 (AISI 304)	EN 1.4404 (AISI 316L)			1
212-1	Drainage plug	EN 1.4301 (AISI 304)	EN 1.4404 (AISI 316L)			4
212-2	Venting plug	EN 1.4401 (AISI 316)				1
212-3	Priming plug	EN 1.4301 (AISI 304)	EN 1.4404 (AISI 316L)			1
245	Coupling guard	EN 1.4301 (AISI 304)				2
273-1	Washer (drainage plug)	EN 1.4301 (AISI 304)	EN 1.4404 (AISI 316L)			4
615	Loose flange	Cast Iron EN GJS 500-7 EN 1563				2

* EPDM (standard)
FPM (option)

** see CONSTRUCTION 3/3

(3/3)

Construction

Pump Name EVMS32 12-0LF5HQ1BEG E/22

Customer	Date	2024-06-14	Company
Contact	Item no.		Issued by
Phone	Project		Phone
E-mail	Project ID	Proiect redenumit 2024-06-14 09:53:20	E-mail

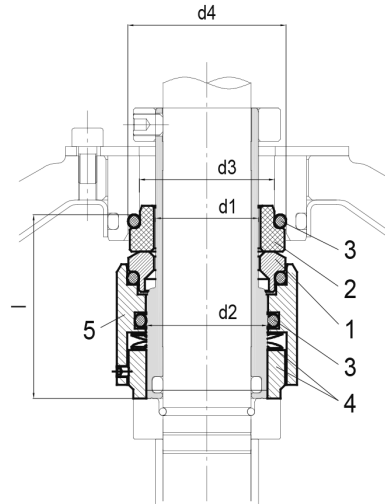

- Standard

Type key	Availability	Max operating pressure	Max operating temperature	Shaft seal type		Shaft seal material									
				Cartridge		1		2		3		4		5	
				Type	Code	Rotating part	Code	Stationary part	Code	Elastomers	Code	Compression spring	Collar	Code	
HQ1BEG	●	25/35 bar	- 30°C to + 140°C	Balanced	(H)	SiC	(Q1)	Carbon	(B)	EPDM	(E)	AISI 316	(G)		

Max operating pressure	d1 [mm]	d2 [mm]	d3 [mm]	d4 [mm]	l [mm]
35 bar	28	33	37	43	50