

Technical data

Pump name EVMS45 8-2LF5HQ1BEG E/30

Customer	Date	2024-06-14	Company
Contact	Item no.		Issued by
Phone	Project		Phone
E-mail	Project ID	Project redenumit 2024-06-14 09:53:	E-mail

Requested data

1	Pump type	VERTICAL MULTISTAGE PUMP	Fluid	Water
2	Number of pumps / Reserve	1 / 0	Liquid temperature °C	20
3	Flow m ³ /h		Kin. viscosity mm ² /s	1.005
4	Head m		Vapour pressure bar	0.0234
5	Geodetic head m		PH value	
6	Inlet pressure (pin) bar	0	Density kg/m ³	998.3
7	Available system NPSH		Solids Weight %	0
8	Ambient temperature °C	20		

Pump

9	Pump name	EVMS45 8-2LF5HQ1BEG E/30	Frequency Hz	50
10	Design	VERTICAL MULTISTAGE PUMP	Installation type	Loose flange
11	Manufacturer	EBARA	Impeller Diameter	Max. mm - Designed mm 141 (No.6) / 128 (No.2) Min. mm -
12	Speed rpm	2950		
13	No. of Stage	8		
14	Connection Suction side		Flow	Operating m ³ /h
15	Connection Discharge side			Max- m ³ /h 60 Min- m ³ /h 21
16	Max Working Pressure bar	25		
17	Shut-off head bar	20.50	Head	Operating m - (Qmax.) m 116.6 - (Qmin.) m 192.8
18	Total weight kg	See the table of "Dimensions".		
19	Shaft power kW			
20			Max. Shaft Power at max. impeller kW	28.40
21	Required pump NPSH m		Efficiency %	

Materials

22	Impeller	AISI 304		
23	Intermediate casing	AISI 304		
24	Bottom casing	EN 1.4308 (ASTM CF8)		
25	Casing cover	AISI 304		
26	Shaft	AISI 304		
27	O-ring	EPDM		

Motor

28	Manufacturer	ATB	Insulation class	F
29	Type	TEFC_EVMS45 8-2/30_400_Three Phase	Phases	3~
30	Specific design	IE3 / 50 Hz / Pole pairs 1	Frame size	200
31	Rated power kW	30	Weight kg	168
32	Number of poles	2	Electric voltage V	400
33	Speed rpm	2945	Electric current A	51
34	Degree of protection	IP56		
35				

Remarks

Performance curve

Pump name **EVMS45 8-2LF5HQ1BEG E/30**

Customer	Date	2024-06-14	Company
Contact	Item no.		Issued by
Phone	Project		Phone
E-mail	Project ID	Proiect redenumit 2024-06-14 09:53:	E-mail

Requested data

1	Flow	m ³ /h	
2	Head	m	
3	Geodetic head	m	

Pump

Operating flow	m ³ /h	Impeller Diameter Designed	mm	141 (No.6) / 128 (No.2)
Operating head	m	Frequency	Hz	50
		Speed	rpm	2950

Test standard: ISO 9906:2012 - Grade3B

Water; 20°C; 998.3kg/m³; 1mm²/s

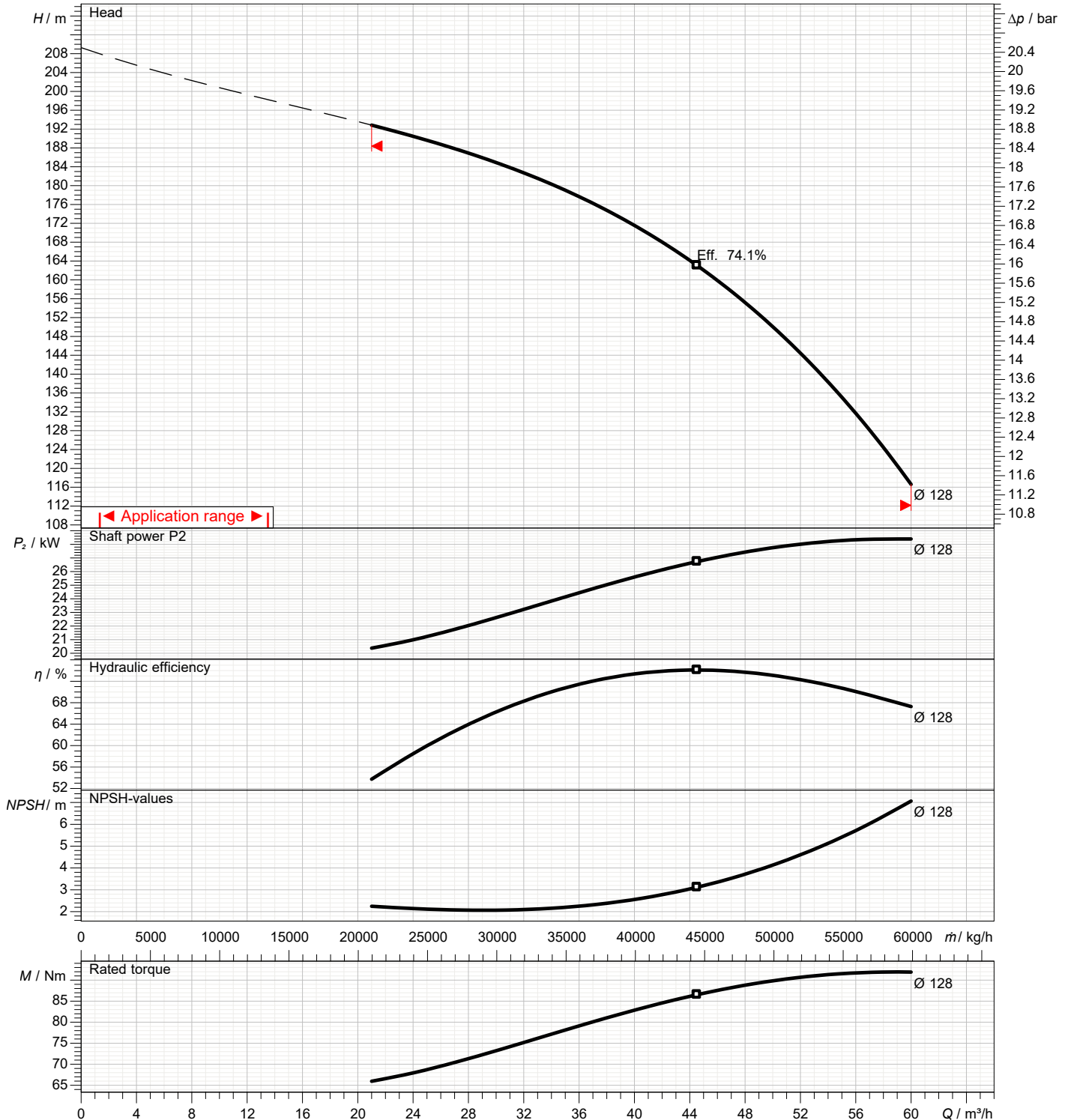

Dimensions

Pump Name EVMS45 8-2LF5HQ1BEG E/30

Customer	Date 2024-06-14	Company
Contact	Item no.	Issued by
Phone	Project	Phone
E-mail	Project ID Proiect redenumit 2024-06-14 09:53:20	E-mail

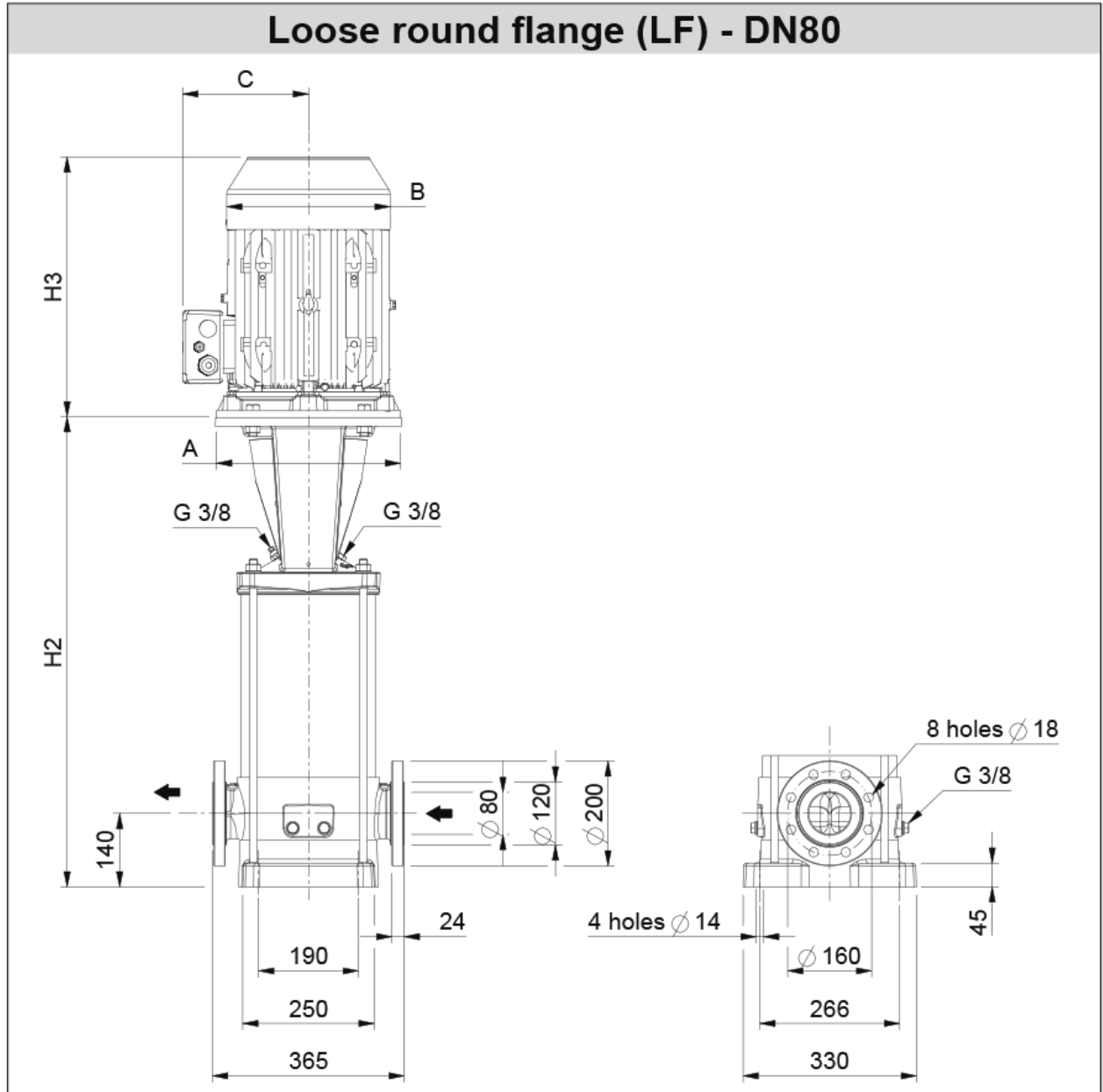

Dimensions in		mm					
1	A	Dia400					
2	B	354					
3	C	280					
4	H2	1184					
5	H2+H3	1736					
6	Weight P&M (kg)	291					
7							
8							
9							
10							
11							
12							
13							
14							
15							

(1/3) Construction

Pump Name EVMS45 8-2LF5HQ1BEG E/30

Customer	Date 2024-06-14	Company
Contact	Item no.	Issued by
Phone	Project	Phone
E-mail	Project ID Proiect redenumit 2024-06-14 09:53:20	E-mail

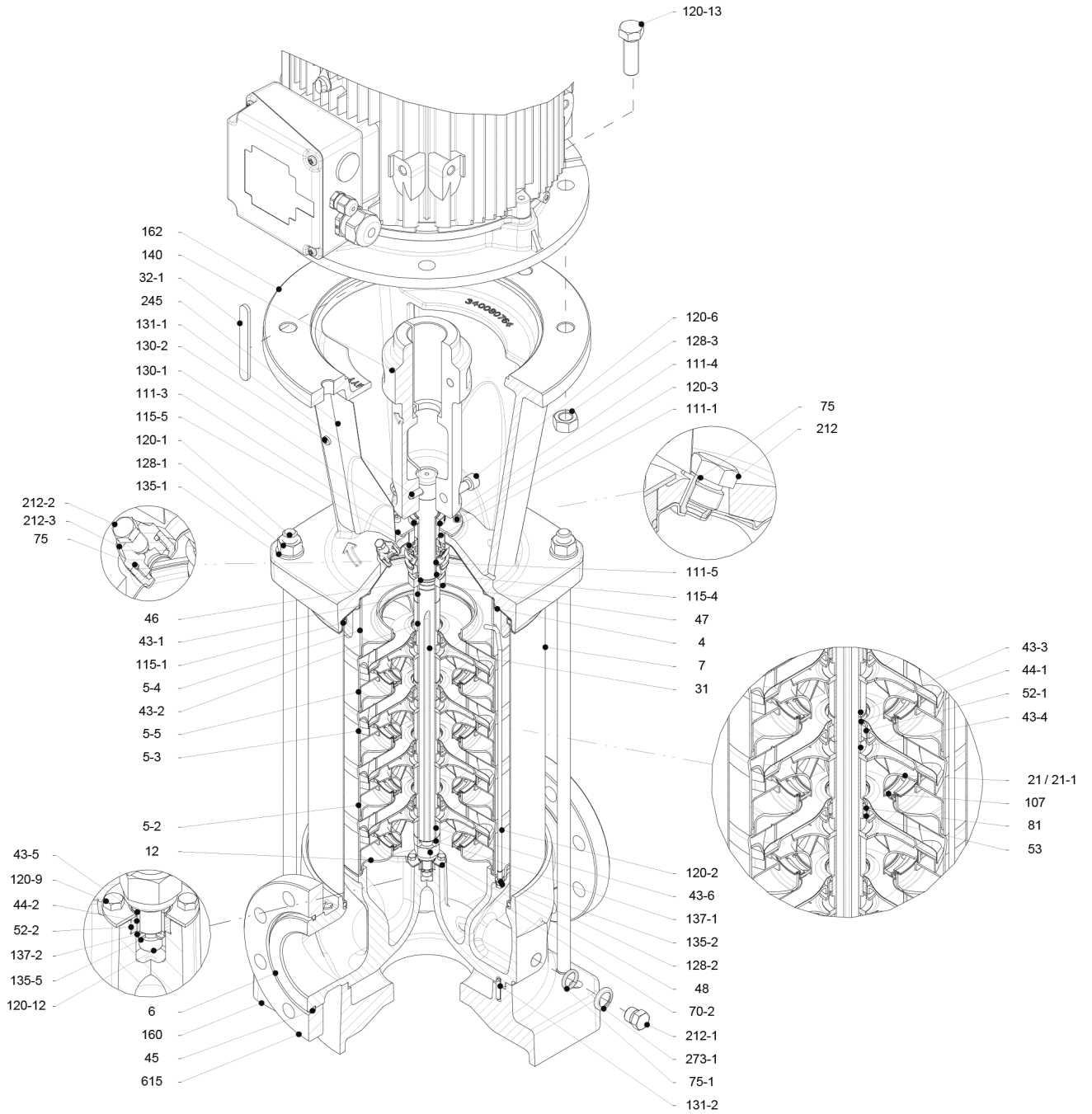

(2/3)

Construction

Pump Name EVMS45 8-2LF5HQ1BEG E/30

Customer	Date	2024-06-14	Company
Contact	Item no.		Issued by
Phone	Project		Phone
E-mail	Project ID	Project redenumit 2024-06-14 09:53:20	E-mail

N°	PART NAME	MATERIAL		DIMENSIONS	STANDARD	QTY
		EVMS	EVMSL			
4	Casing cover	EN 1.4301 (AISI 304)	EN 1.4404 (AISI 316L)			1
5-2	Intermediate casing	EN 1.4301 (AISI 304)	EN 1.4404 (AISI 316L)			6
5-3	Intermediate casing with bearing	EN 1.4301 (AISI 304)	EN 1.4404 (AISI 316L)			1
5-4	Discharge casing	EN 1.4301 (AISI 304)	EN 1.4404 (AISI 316L)			1
5-5	Top intermediate casing	EN 1.4301 (AISI 304)	EN 1.4404 (AISI 316L)			1
6	Bottom casing	EN 1.4308 (ASTM CF8)	EN 1.4408 (ASTM CF8M)			1
7	Outer casing	EN 1.4301 (AISI 304)	EN 1.4404 (AISI 316L)			1
12	Suction cover	EN 1.4301 (AISI 304)	EN 1.4404 (AISI 316L)			1
21	Impeller	EN 1.4301 (AISI 304)	EN 1.4404 (AISI 316L)			6
21-1	Reduced impeller	EN 1.4301 (AISI 304)	EN 1.4404 (AISI 316L)			2
31	Shaft	EN 1.4301 (AISI 304)	EN 1.4404 (AISI 316L) - EN 1.4462 (AISI 329A)			1
32-1	Adjuster key	EN 1.4301 (AISI 304)				1
43-1	Shaft sleeve (mechanical seal)	EN 1.4301 (AISI 304)	EN 1.4404 (AISI 316L)			1
43-2	Shaft sleeve (intermediate)	EN 1.4301 (AISI 304)	EN 1.4404 (AISI 316L)			7
43-3	Shaft sleeve (bearing)	EN 1.4301 (AISI 304)	EN 1.4404 (AISI 316L)			1
43-4	Shaft sleeve (adjustment)	EN 1.4301 (AISI 304)	EN 1.4404 (AISI 316L)			1
43-5	Shaft sleeve (last stage)	EN 1.4301 (AISI 304)	EN 1.4404 (AISI 316L)			1
43-6	Shaft sleeve (adjustment)	EN 1.4301 (AISI 304)	EN 1.4404 (AISI 316L)			1
44-1	Shaft sleeve bearing	Tungsten carbide				1
44-2	Shaft sleeve (bearing)	Tungsten carbide				1
45	Flange holder	EN 1.4301 (AISI 304)				4
46	Ring (mechanical seal)	EN 1.4404 (AISI 316L)				1
47	Ring holder	EN 1.4404 (AISI 316L)				1
48	Impeller nut	EN 1.4301 (AISI 304) with inox insert	EN 1.4401 (AISI 316) with inox insert			1
52-1	Sleeve bearing	Tungsten carbide				1
52-2	Bearing sleeve (bottom casing)	Tungsten carbide				1
53	Bush holder	EN 1.4301 (AISI 304)	EN 1.4404 (AISI 316L)			8
70-2	Ring for bearing sleeve	EN 1.4301 (AISI 304)	EN 1.4404 (AISI 316L)			1
75	O-Ring (priming plug)	EPDM / FPM **		Ø12.37x2.62	OR 3050	2
75-1	O-Ring (drainage plug)	EPDM / FPM **				4
81	Bush	PTFE				7
107	Liner ring	EN 1.4301 (AISI 304) + PPS	EN 1.4404 (AISI 316L) + PPS			8
111-1	Mechanical seal	---				1
111-3	Mechanical seal seat	EN 1.4301 (AISI 304)	EN 1.4401 (AISI 316)			1
111-4	Seal holder	EN 1.4404 (AISI 316L)				1
111-5	Mechanical seal cartridge sleeve	EN 1.4301 (AISI 304)	EN 1.4404 (AISI 316L)			1
115-1	O-Ring (outer casing)	EPDM / FPM **		Ø240.66x5.34	OR 6945	2
115-4	O-Ring (cartridge sleeve)	EPDM / FPM **		Ø23.39x3.53	OR 4093	1
115-5	O-Ring (seal flange)	EPDM / FPM **		Ø44.04x3.53	OR 4175	1
120-1	Tie rod	EN 1.4057 (AISI 431)				4
120-2	Tie rod (stage)	EN 1.4301 (AISI 304)	EN 1.4401 (AISI 316)			2
120-3	Screw (seal flange)	A2-70		M5x12	ISO 4762	4
120-6	Screw (pump coupling)	from 11 kW to 30 kW	Galvanized steel 8.8 strength class ISO 898/1	M10x30	ISO 4762	4
120-9	Screw (bottom casing)	A2-70		M5x8	ISO 4017	4
120-12	Screw (shaft)	A2-70		M6x16	ISO 4762	1
120-13	Screw for motor	MEC 200-225	Galvanized steel 8.8 strength class ISO 898/1	M16x60	ISO 4014	4
128-1	Nut (tie rod)	A2-70		M16	ISO 4032	4
128-2	Nut (casing tie rod)	A2-70		M5	ISO 4032	4
128-3	Nut (motor)	MEC 160-180-200-225	Galvanized steel	M16	ISO 4032	4
130-1	Set screw	EN 1.4301 (AISI 304)		M6x8	ISO 4026	3
130-2	Screw for coupling guard	A2-70		M5x6	UNI 7687	4
131-1	Pin for shaft	above 5.5 kW	Carbon Steel	Ø8X50	ISO 2338	1
131-2	Elastic pin	EN 1.4301 (AISI 304)		Ø6x26	ISO 8752	1
135-1	Washer (tie rod)	EN 1.4301 (AISI 304)		Ø16	ISO 7089	4
135-2	Washer (casing tie rod)	EN 1.4301 (AISI 304)	EN 1.4404 (AISI 316)	Ø5.1	UNI 1751	2
135-5	Washer (impeller nut)	EN 1.4301 (AISI 304)	EN 1.4404 (AISI 316L)			1
137-1	Impeller spacer	EN 1.4301 (AISI 304)	EN 1.4404 (AISI 316L)			1
137-2	Shaft spacer	EN 1.4301 (AISI 304)	EN 1.4404 (AISI 316L)			1
140	Coupling	from 5.5 kW to 30 kW	Cast Iron EN GJL250 EN 1561			2
160	Base	Cast Iron EN GJL200 EN 1561				1
162	Motor bracket	up to 30 kW	Cast Iron EN GJS 400-15 EN 1563			1
212	Priming plug	EN 1.4301 (AISI 304)	EN 1.4404 (AISI 316L)			1
212-1	Drainage plug	EN 1.4301 (AISI 304)	EN 1.4404 (AISI 316L)			4
212-2	Venting plug	EN 1.4401 (AISI 316)				1
212-3	Priming plug	EN 1.4301 (AISI 304)	EN 1.4404 (AISI 316L)			1
245	Coupling guard	EN 1.4301 (AISI 304)				2
273-1	Washer (drainage plug)	EN 1.4301 (AISI 304)	EN 1.4404 (AISI 316L)			4
615	Loose flange	Cast Iron EN GJS 500-7 EN 1563				2

* EPDM (standard)
FPM (option)

** see CONSTRUCTION 3/3

(3/3)

Construction

Pump Name EVMS45 8-2LF5HQ1BEG E/30

Customer	Date	2024-06-14	Company
Contact	Item no.		Issued by
Phone	Project		Phone
E-mail	Project ID	Proiect redenumit 2024-06-14 09:53:20	E-mail

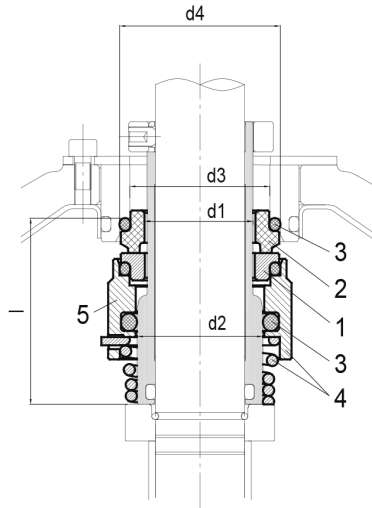

- Standard

Type key	Availability	Max operating pressure	Max operating temperature	Shaft seal type		Shaft seal material									
				Cartridge		1 Rotating part		2 Stationary part		3 Elastomers		4 Compression spring		5 Collar	
				Type	Code	Code	Code	Code	Code	Code	Code	Code	Code		
HQ1BEG	●	25/35 bar	- 30°C to + 140°C	Balanced	(H)	SIC	(Q1)	Carbon	(B)	EPDM	(E)	AISI 316	(G)		

Max operating pressure	d1 [mm]	d2 [mm]	d3 [mm]	d4 [mm]	l [mm]
25 bar	28	33	37	43	50