

Technical Data

Pump Name

EVMSG-K20 1N5Q1BEGE/1.5 TT

Customer	Date	2024-06-14	Company
Contact	Item no.		Issued by
Phone	Project		Phone
E-mail	Project ID	Proiect redenumit 2024-06-14 17:13:34	E-mail

Requested data

1	Pump type	VERTICAL MULTISTAGE PUMP	Fluid	Water
2	Number of pumps / Reserve	1 / 0	Liquid temperature	°C
3	Flow	m³/h	Kin. viscosity	mm²/s
4	Head	m	Vapour pressure	bar
5	Geodetic head	m	PH value	
6	Inlet pressure (pin)	bar	Density	kg/m³
7	Available system NPSH		Solids	Weight %
8	Ambient temperature	°C		

Pump

9	Pump Name	EVMSG-K20 1N5Q1BEGE/1.5 TT	Frequency	Hz	50		
10	Design	VERTICAL MULTISTAGE PUMP	Installation type		Oval flange (STANDARD)		
11	Manufacturer	EBARA	Impeller Diameter	Max.	mm		
12	Speed	rpm		2850	Designed	mm	
13	No. of Stage			1	Min.	mm	
14	Connection	Suction side	Flow	Operating	m³/h		
15	Connection	Discharge side		Max-	m³/h	28.8	
16	Max Working Pressure	bar		16	Min-	m³/h	10.8
17	Shut-off head	bar	1.67	Head	Operating	m	
18	Total weight	kg	See the table of "Dimensions".		- (Qmax.)	m	2.3
19	Shaft power	kW			- (Qmin.)	m	14.3
20			Max. Shaft Power at max. impeller	kW		1.25	
21	Required pump NPSH	m	Efficiency	%			

Materials

22	Impeller	AISI 304		
23	Intermediate casing	AISI 304		
24	Bottom casing	Cast iron		
25	Shaft	AISI 304		
26	O-ring	EPDM		
27				

Motor

28	Manufacturer	ETM	Insulation class	F	
29	Type	TEFC_EVMS-K20 1/1.5 TT_400_Three Phase	Phases	3~	
30	Specific design	IE3 / 50 Hz / Pole pairs 1	Frame size	90	
31	Rated power	kW	1.5	Weight	kg
32	Number of poles	2	Electric voltage	V	400
33	Speed	rpm	2885	Electric current	A
34	Degree of protection	IP 55			
35					

Remarks

Performance Curve

Pump Name

EVMSG-K20 1N5Q1BEGE/1.5 TT

Customer	Date	2024-06-14	Company
Contact	Item no.		Issued by
Phone	Project		Phone
E-mail	Project ID	Proiect redenumit 2024-06-14 17:13:34	E-mail

Requested data

1	Flow	m³/h	
2	Head	m	
3	Geodetic head	m	

Pump

Operating flow	m³/h		Frequency	Hz	50
Operating head	m		Number of poles		2
Impeller diameter designed	mm	113	Speed	rpm	2850

Test standard: ISO 9906:2012 - Grade3B

Water; 20°C; 998.3kg/m³; 1mm²/s

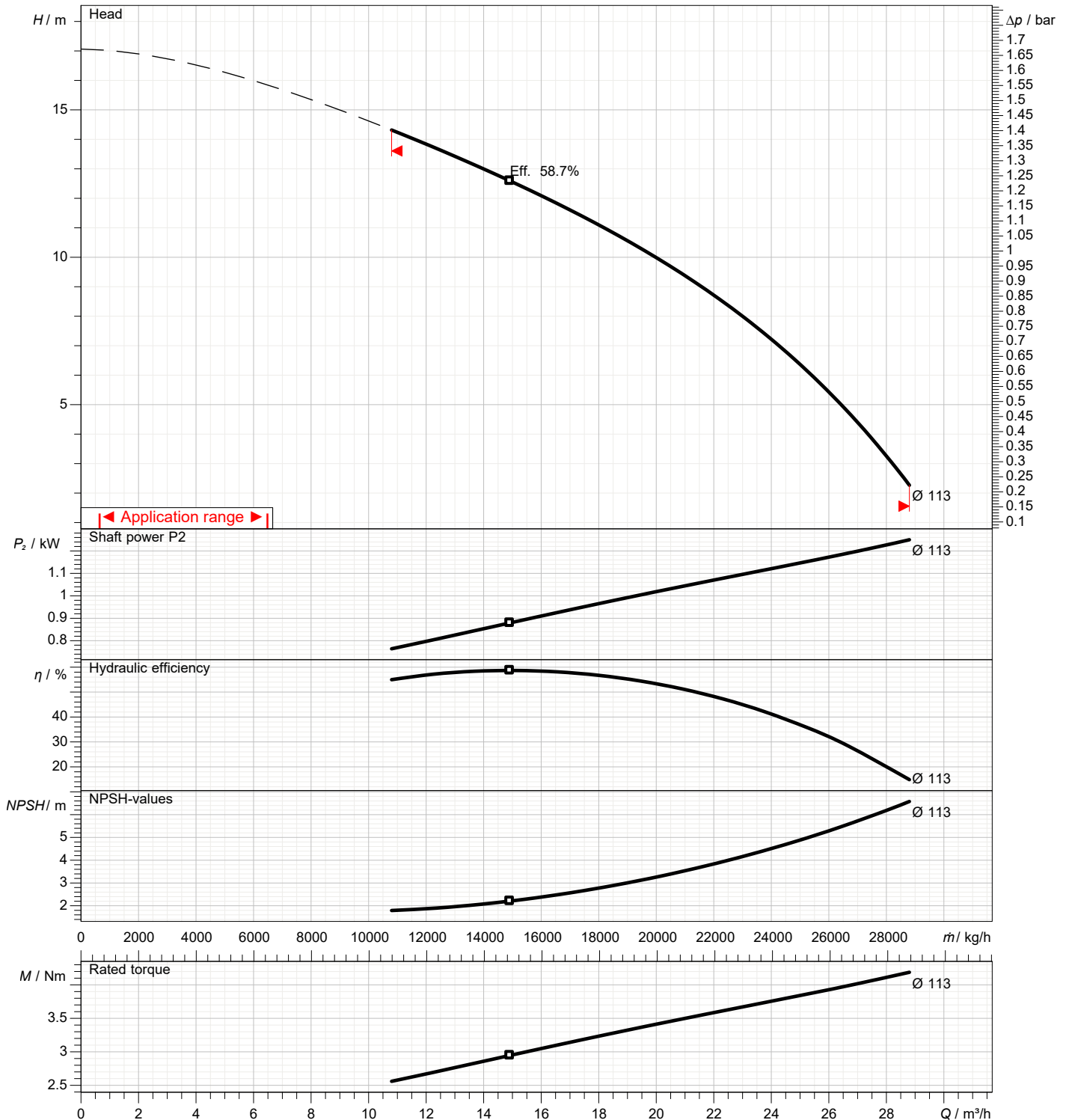

Dimensions

Pump name EVMSG-K20 1N5Q1BEGE/1.5 TT

Customer	Date 2024-06-14	Company
Contact	Item no.	Issued by
Phone	Project	Phone
E-mail	Project ID Proiect redenumit 2024-06-14 17:13:34	E-mail

EVMSG-K20

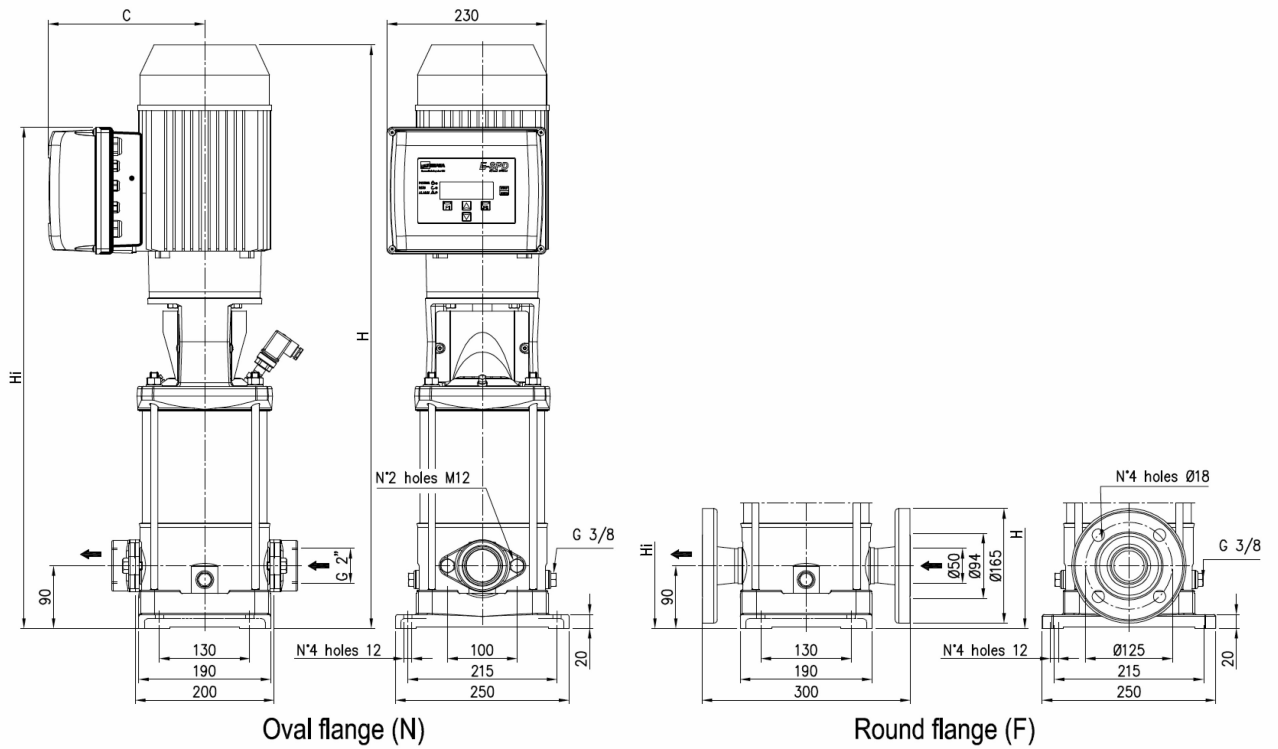

Dimensions in		mm						
1	C	203						
2	C	119						
3	H	678						
4	Hi	632						
5								
6								
7								
8								
9								
10								
11								
12								
13								
14								
15								

(1/2) Construction

Pump name EVMSG-K20 1N5Q1BEGE/1.5 TT

Customer	Date 2024-06-14	Company
Contact	Item no.	Issued by
Phone	Project	Phone
E-mail	Project ID Proiect redenumit 2024-06-14 17:13:34	E-mail

EVMS-K

EVMSL-K

EVMSG-K



POS	PART NAME	MATERIAL	QUANTITY
1	EVMSG-K PUMP	EN-GJL-250 (CAST IRON)	1
	EVMS-K PUMP	EN 1.4301 (AISI 304)	1
	EVMSL-K PUMP	EN 1.4404 (AISI 316L)	1
2	ELETRIC MOTOR	ALUMINIUM	1
3	INVERTER	ALUMINIUM-PLASTIC	1
4	PRESSURE TRANSDUCER	EN 1.4301 (AISI 304)	1

(2/2)

Construction

Pump name EVMSG-K20 1N5Q1BEGE/1.5 TT

Customer	Date 2024-06-14	Company
Contact	Item no.	Issued by
Phone	Project	Phone
E-mail	Project ID Proiect redenumit 2024-06-14 17:13:34	E-mail

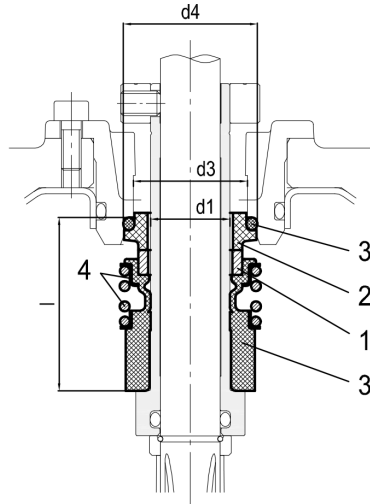

● : Standard

Pump model	Max operating temperature	Shaft seal type		Shaft seal material								Type key		
		Cartridge		1		2		3		4			5	
		Unbalanced	Balanced	Rotating Part	Code	Stationary Part	Code	Elastomers	Code	Compression spring	Collar		Code	
up to 16 bar	- 30°C to + 120°C	●		SiC	(Q1)	Carbon	(B)	EPDM	(E)	AISI 316		(G)	Q1BEG	

Max operating pressure	d1 [mm]	d2 [mm]	d3 [mm]	d4 [mm]	l [mm]
16 bar	20	-	29	35	37.5