

Technical Data

Pump Name

EVMSG32 1-0F6BQ1EG/3.0

Customer	Date	2024-07-02	Company
Contact	Item no.		Issued by
Phone	Project		Phone
E-mail	Project ID	Proiect redenumit 2024-07-02 22:34:28	E-mail

Requested data

1	Pump type	VERTICAL MULTISTAGE PUMP	Fluid	Water
2	Number of pumps / Reserve	1 / 0	Liquid temperature	°C
3	Flow	m³/h	Kin. viscosity	mm²/s
4	Head	m	Vapour pressure	bar
5	Geodetic head	m	PH value	
6	Inlet pressure (pin)	bar	Density	kg/m³
7	Available system NPSH		Solids	Weight %
8	Ambient temperature	°C		

Pump

9	Pump Name	EVMSG32 1-0F6BQ1EG/3.0	Frequency	Hz	60	
10	Design	VERTICAL MULTISTAGE PUMP	Installation type		Round flange	
11	Manufacturer	EBARA	Impeller Diameter	Max.	mm	
12	Speed	rpm		3450	Designed	mm
13	No. of Stage			1	Min.	mm
14	Connection	Suction side	Flow	Operating	m³/h	
15	Connection	Discharge side		Max-	m³/h	48
16	Max Working Pressure	bar		16	Min-	m³/h
17	Shut-off head	bar	2.82	Head	Operating	m
18	Total weight	kg	See the table of "Dimensions".		- (Qmax.)	m
19	Shaft power	kW			- (Qmin.)	m
20			Max. Shaft Power at max. impeller	kW	3.00	
21	Required pump NPSH	m	Efficiency	%		

Materials

22	Impeller	AISI 304		
23	Intermediate casing	AISI 304		
24	Bottom casing	Cast Iron EN GJL-250 EN 1561		
25	Casing cover	AISI 304		
26	Shaft	AISI 304		
27	O-ring	EPDM		

Motor

28	Manufacturer	ETM	Insulation class	F	
29	Type	TEFC_EVMS32 1-0/3.0_220_Three Phase	Phases	3~	
30	Specific design	- / 60 Hz / Pole pairs 1	Frame size	100	
31	Rated power	kW	3	Weight	kg
32	Number of poles		2	Electric voltage	V
33	Speed	rpm	3500	Electric current	A
34	Degree of protection	IP55			
35					

Remarks

Performance Curve

Pump Name

EVMSG32 1-0F6BQ1EG/3.0

Customer	Date	2024-07-02	Company
Contact	Item no.		Issued by
Phone	Project		Phone
E-mail	Project ID	Project redenumit 2024-07-02 22:34:28	E-mail

Requested data

1	Flow	m³/h	
2	Head	m	
3	Geodetic head	m	

Pump

Operating flow	m³/h		Frequency	Hz	60
Operating head	m		Number of poles		2
Impeller diameter designed	mm	118	Speed	rpm	3450

Test standard: ISO 9906:2012 - Grade3B

Water; 20°C; 998.3kg/m³; 1mm²/s

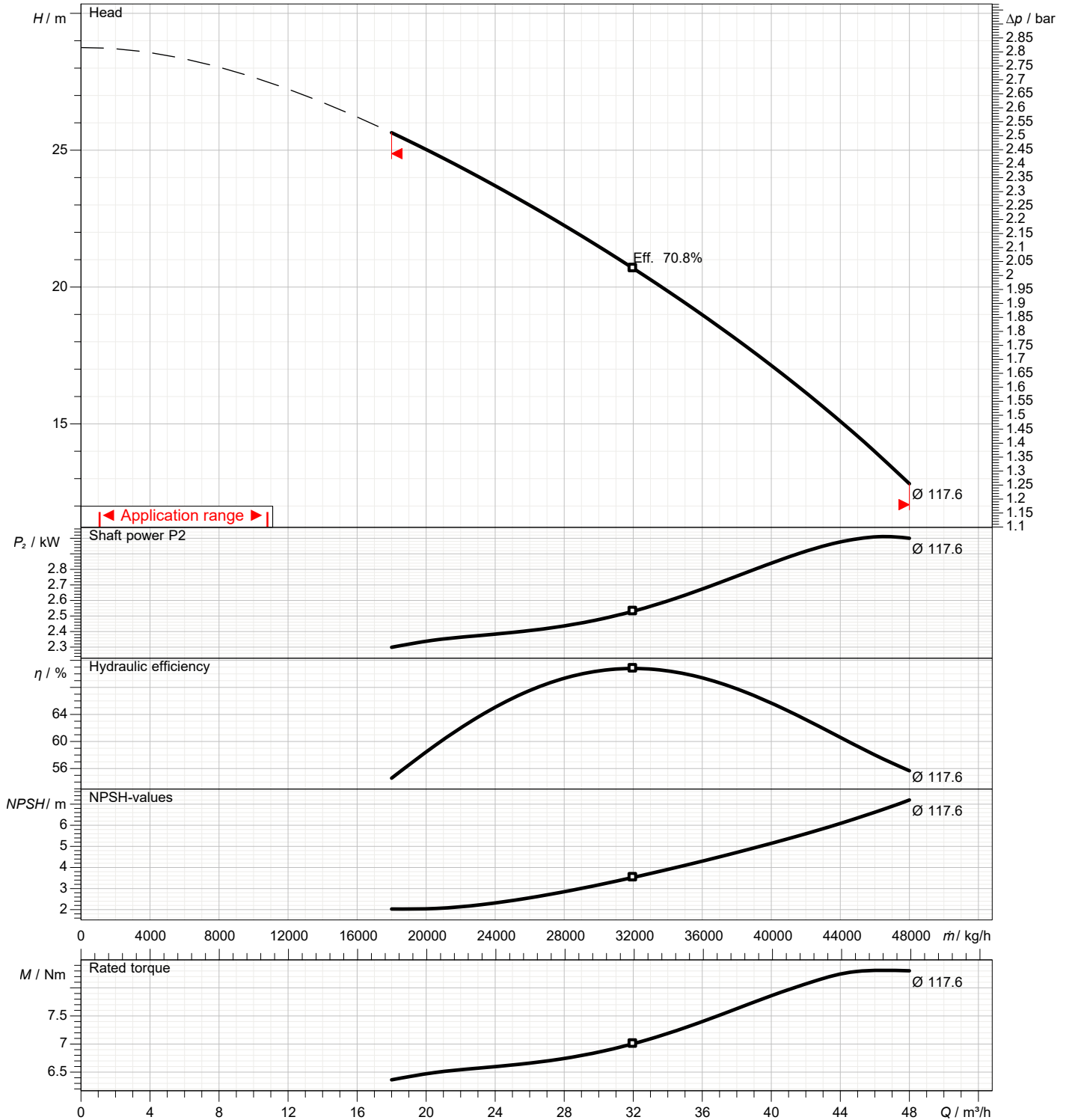

Dimensions

Pump Name EVMSG32 1-0F6BQ1EG/3.0

Customer	Date 2024-07-02	Company
Contact	Item no.	Issued by
Phone	Project	Phone
E-mail	Project ID Proiect redenumit 2024-07-02 22:34:28	E-mail

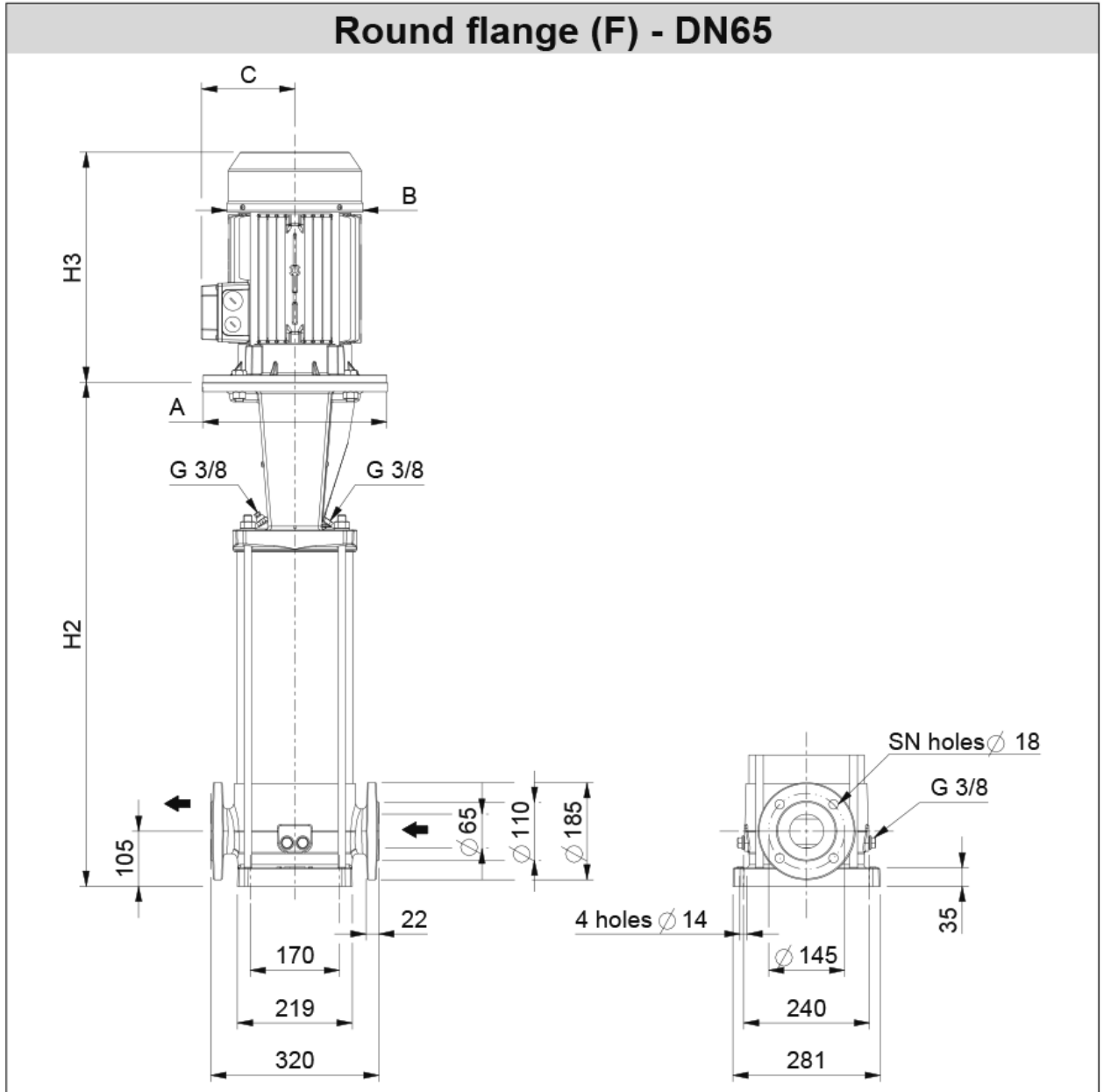

Dimensions in		mm						
1	A	Dia160						
2	B	176						
3	C	123						
4	H2	461						
5	H2+H3	803						
6	SN	4						
7	Weight P&M (kg)	67.3						
8								
9								
10								
11								
12								
13								
14								
15								

(1/3)

Construction

Pump Name EVMSG32 1-0F6BQ1EG/3.0

Customer	Date 2024-07-02	Company
Contact	Item no.	Issued by
Phone	Project	Phone
E-mail	Project ID Proiect redenumit 2024-07-02 22:34:28	E-mail

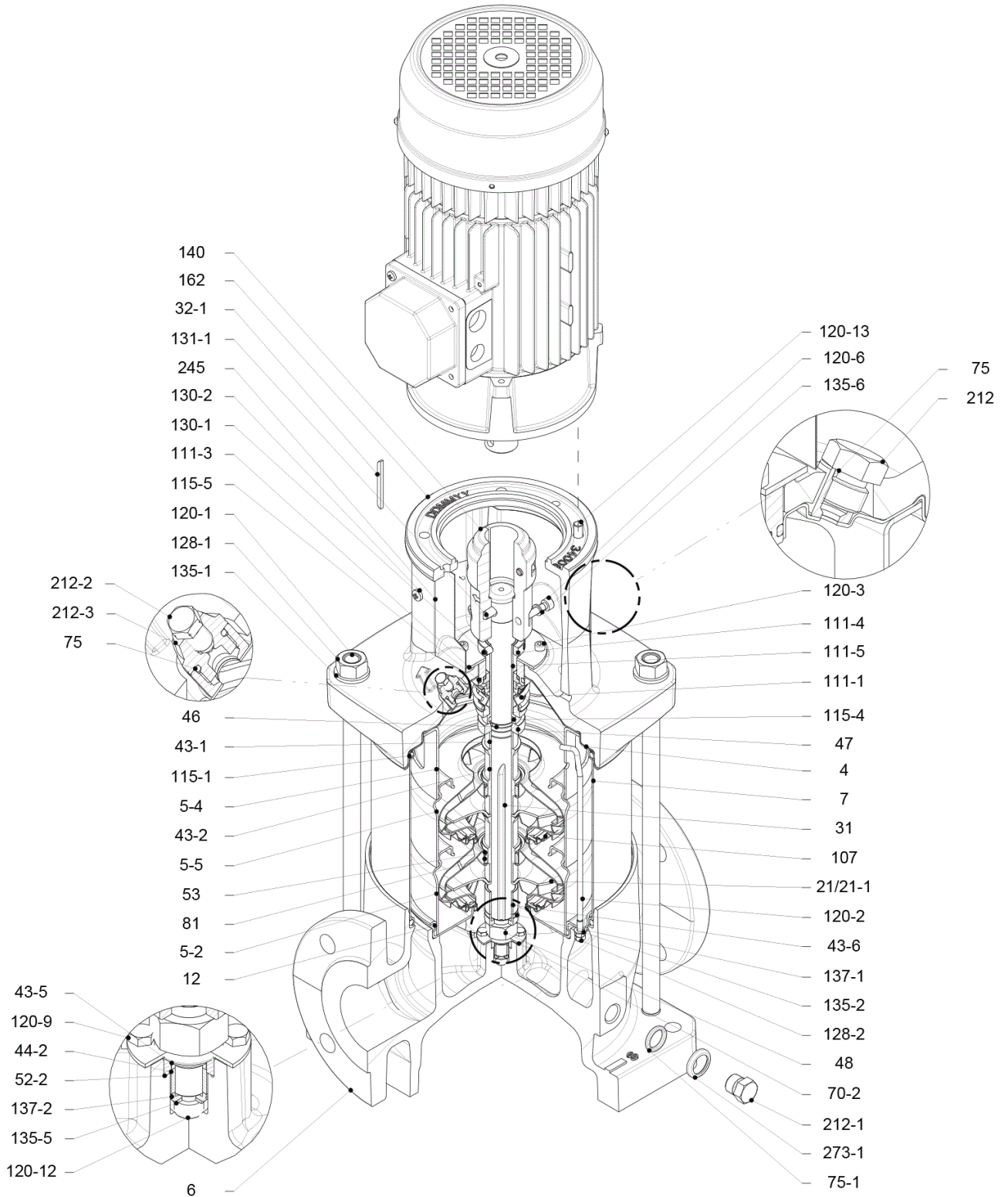

(2/3)

Construction

Pump Name EVMSG32 1-0F6BQ1EG/3.0

Customer	Date	2024-07-02	Company
Contact	Item no.		Issued by
Phone	Project		Phone
E-mail	Project ID	Proiect redenumit 2024-07-02 22:34:28	E-mail

N°	PART NAME	MATERIAL EVMSG	DIMENSIONS	STANDARD	QTY
4	Casing cover	EN 1.4301 (AISI 304)			1
5-4	Discharge casing	EN 1.4301 (AISI 304)			1
5-5	Top intermediate casing	EN 1.4301 (AISI 304)			1
6	Bottom casing	Cast Iron EN GJL-250 EN 1561 Cast Iron EN GJS 400-15 EN 1563			1
7	Outer casing	EN 1.4301 (AISI 304)			1
12	Suction cover	EN 1.4301 (AISI 304)			1
21	Impeller	EN 1.4301 (AISI 304)			1
31	Shaft	EN 1.4301 (AISI 304)			1
32-1	Adjuster key	EN 1.4301 (AISI 304)			1
43-1	Shaft sleeve (mechanical seal)	EN 1.4301 (AISI 304)			1
43-2	Shaft sleeve (intermediate)	EN 1.4301 (AISI 304)			1
43-5	Shaft sleeve (last stage)	EN 1.4301 (AISI 304)			1
43-6	Shaft sleeve (adjustment)	EN 1.4301 (AISI 304)			1
44-2	Shaft sleeve (bearing)	Tungsten carbide			1
46	Ring (mechanical seal)	EN 1.4404 (AISI 316L)			1
47	Ring holder	EN 1.4301 (AISI 304)			1
48	Impeller nut	EN 1.4301 (AISI 304) with inox insert			1
52-2	Sleeve bearing (bottom casing)	Tungsten carbide			1
53	Bush holder	EN 1.4301 (AISI 304)			1
70-2	Ring for bearing sleeve	EN 1.4301 (AISI 304)			1
75	O-Ring (priming plug)	EPDM / FPM *	Ø12.37x2.62	OR 3050	2
75-1	O-Ring (drainage plug)	EPDM / FPM *			4
81	Bush	PTFE			1
107	Liner ring	EN 1.4301 (AISI 304) + PPS			1
111-1	Mechanical seal	- - - **			1
111-3	Mechanical seal seat	EN 1.4301 (AISI 304)			1
111-4	Seal holder	EN 1.4404 (AISI 316L)			1
111-5	Mechanical seal cartridge sleeve	EN 1.4301 (AISI 304)			1
115-1	O-Ring (outer casing)	EPDM / FPM *	Ø240.66x5.34	OR 6945	2
115-4	O-Ring (cartridge sleeve)	EPDM / FPM *	Ø23.39x3.53	OR 4093	1
115-5	O-Ring (seal flange)	EPDM / FPM *	Ø44.04x3.53	OR 4175	1
120-1	Tie rod	EN 1.4057 (AISI 431)			4
120-2	Tie rod (stage)	EN 1.4301 (AISI 304)			2
120-3	Screw (seal flange)	A2-70	M5x12	ISO 4762	4
120-6	Screw (pump coupling)	up to 4.0 kW Galvanized steel 8.8 strength class ISO 898/1	M6x25	ISO 4762	4
120-9	Screw (bottom casing)	A2-70	M5x8	ISO 4017	4
120-12	Screw (shaft)	A2-70	M6x16	ISO 4762	1
120-13	Screw for motor	MEC 100-112 Galvanized steel 8.8 strength class ISO 898/1	M8x20	ISO 4017	4
128-1	Nut (tie rod)	A2-70	M16	ISO 4032	4
128-2	Nut (casing tie rod)	A2-70	M5	ISO 4032	8
128-6	Nut (aluminium coupling)	MEC 100-112 Galvanized steel	M6	ISO 4032	4
130-1	Set screw	EN 1.4301 (AISI 304)	M6x8	ISO 4026	3
130-2	Screw for coupling guard	A2-70	M5x6	UNI 7687	4
131-1	Pin for shaft	up to 4.0 kW Carbon Steel	Ø8x42	ISO 2338	1
135-1	Washer (tie rod)	EN 1.4301 (AISI 304)	Ø16	ISO 7089	4
135-2	Washer (casing tie rod)	EN 1.4301 (AISI 304)	Ø5.1	UNI 1751	2
135-5	Washer (impeller nut)	EN 1.4301 (AISI 304)			1
135-6	Washer (aluminium coupling)	up to 4.0 kW Carbon Steel			4
137-1	Impeller spacer	EN 1.4301 (AISI 304)			1
137-2	Shaft spacer	EN 1.4301 (AISI 304)			1
140	Coupling	up to 4.0 kW Die cast Aluminium EN AB-AISI11 Cu2 (Fe)			2
162	Motor bracket	up to 30 kW Cast Iron EN GJS 400-15 EN 1563			1
212	Priming plug	EN 1.4301 (AISI 304)			1
212-1	Drainage plug	EN 1.4301 (AISI 304)			4
212-2	Venting plug	EN 1.4401 (AISI 316)			1
212-3	Priming plug	EN 1.4301 (AISI 304)			1
245	Coupling guard	EN 1.4301 (AISI 304)			2
273-1	Washer (drainage plug)	EN 1.4301 (AISI 304)			4

* EPDM (standard)
FPM (option)

** see CONSTRUCTION 3/3

(3/3)

Construction

Pump Name EVMSG32 1-0F6BQ1EG/3.0

Customer	Date 2024-07-02	Company
Contact	Item no.	Issued by
Phone	Project	Phone
E-mail	Project ID Proiect redenumit 2024-07-02 22:34:28	E-mail

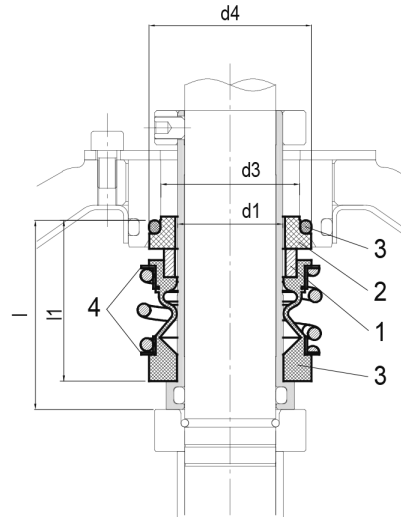

- Standard

Type key	Availability	Max operating pressure	Max operating temperature	Shaft seal type		Shaft seal material							
				Type	Code	1 Rotating part	Code	2 Stationary part	Code	3 Elastomers	Code	4 Compression spring	5 Collar
BQ1EG	●	16 bar	- 30°C to + 120°C	Unbalanced	(-)	Carbon	(B)	SiC	Q1	EPDM	(E)	AISI 316	(G)

Max operating pressure	d1 [mm]	d3 [mm]	d4 [mm]	l [mm]	l1 [mm]
16 bar	28	37	43	50	42.5