

# Technical Data

Pump Name

GS2 40-250-260/B/30

Customer	Date	2024-06-14	Company
Contact	Item no.		Issued by
Phone	Project		Phone
E-mail	Project ID	Proiect redenumit 2024-06-14 18:50:3	E-mail

## Requested data

1	Pump type	End Suction Volute Pump	Fluid	Water
2	Number of pumps / Reserve	1 / 0	Liquid temperature	°C 20
3	Flow	m³/h	Kin. viscosity	mm²/s 1.005
4	Head	m	Vapour pressure	bar 0.0234
5	Geodetic head	m	PH value	
6	Inlet pressure (pin)	bar	Density	kg/m³ 998.3
7	Available system NPSH		Solids	Weight % 0
8	Ambient temperature	°C 20		

## Pump

9	Pump Name	GS2 40-250-260/B/30	Frequency	Hz	50
10	Design	End Suction Volute Pump	Installation type	with base, motor	
11	Manufacturer	EBARA	Impeller Diameter	Max.	mm 260
12	Speed	rpm 2900		Designed	mm 260
13	No. of Stage	1		Min.	mm 211
14	Connection	Suction side EN PN16	Flow	Operating	m³/h
15	Connection	Discharge side EN PN16		Max-	m³/h 81.2
16	Max Working Pressure	bar 16		Min-	m³/h 10.6
17	Shut-off head	bar 9.40	Head	Operating	m
18	Total weight	kg See the table of "Dimensions".		- (Qmax.)	m 75.8
19	Shaft power	kW		- (Qmin.)	m 96.2
20			Max. Shaft Power at max. impeller	kW	24.20
21	Required pump NPSH	m	Efficiency	%	

## Materials

22	Casing	Cast iron		
23	Impeller	Cast iron		
24	Shaft	Cr. Steel		
25	Case wear ring	Bronze		
26	O-ring	EPDM		
27	Mechanical seal	SiC/Carbon/EPDM		

## Motor

28	Manufacturer	TECHTOP	Insulation class	F
29	Type	200L1_30_3_400	Phases	3~
30	Specific design	TEFC/B3/IE3/TC / 50 Hz / Pole pairs 1	Frame size	200L1
31	Rated power	kW 30	Weight	kg 261
32	Number of poles	2	Electric voltage	V 400
33	Speed	rpm 2925	Electric current	A 52.7
34	Degree of protection	IP55		
35				

## Remarks

# Performance Curve

Pump Name

GS2 40-250-260/B/30

Customer	Date	2024-06-14	Company
Contact	Item no.		Issued by
Phone	Project		Phone
E-mail	Project ID	Proiect redenumit 2024-06-14 18:50:31	E-mail

**Requested data**

1	Flow	m³/h	
2	Head	m	
3	Geodetic head	m	

**Pump**

Operating flow	m³/h		Frequency	Hz	50
Operating head	m		Number of poles		2
Impeller diameter designed	mm	260	Speed	rpm	2900

Test standard: ISO 9906:2012 - Grade3B

Water; 20°C; 998.3kg/m³; 1mm²/s

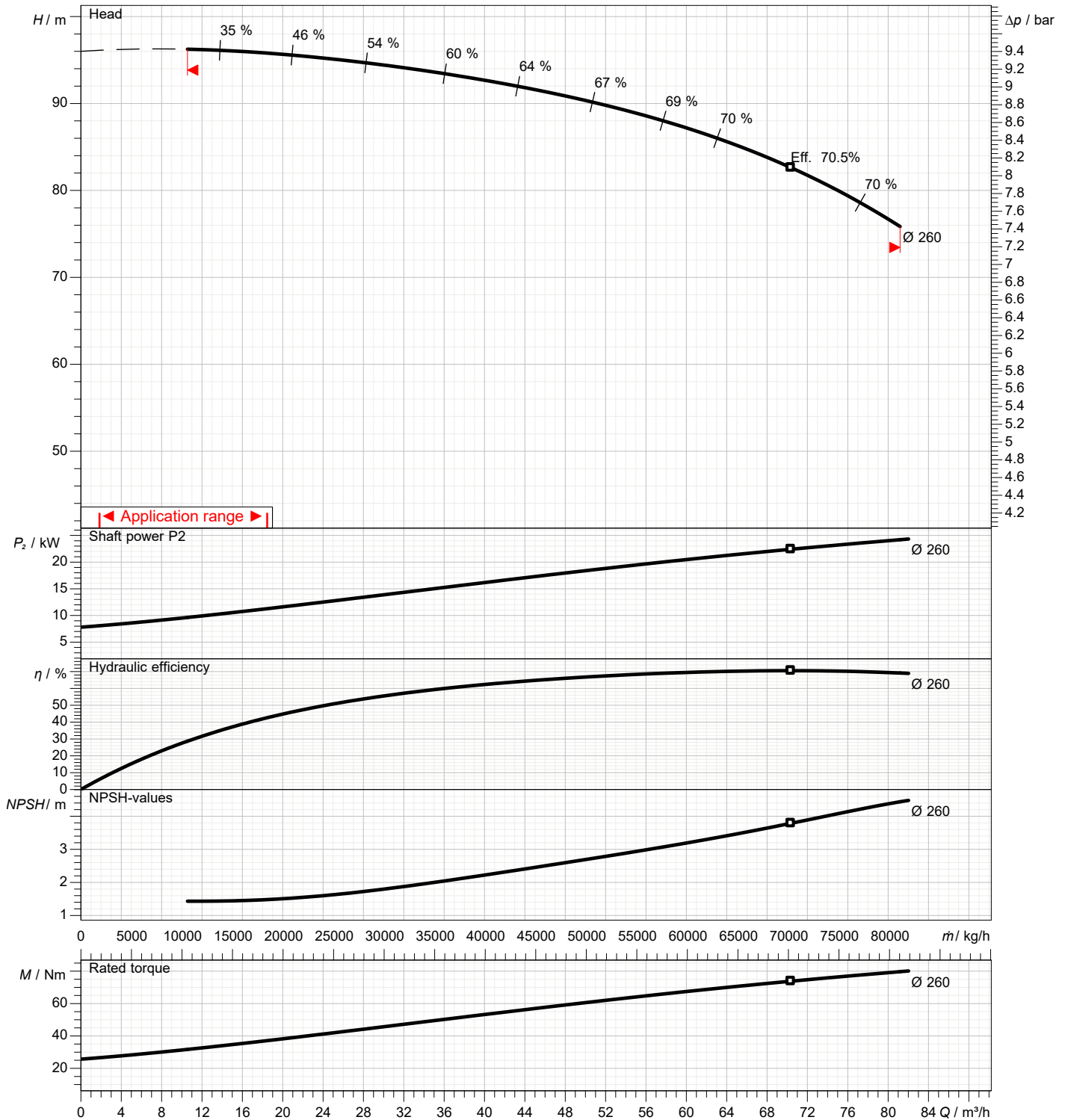

# Dimensions

Pump name GS2 40-250-260/B/30

Customer	Date 2024-06-14	Company
Contact	Item no.	Issued by
Phone	Project	Phone
E-mail	Project ID Proiect redenumit 2024-06-14 18:50:31	E-mail

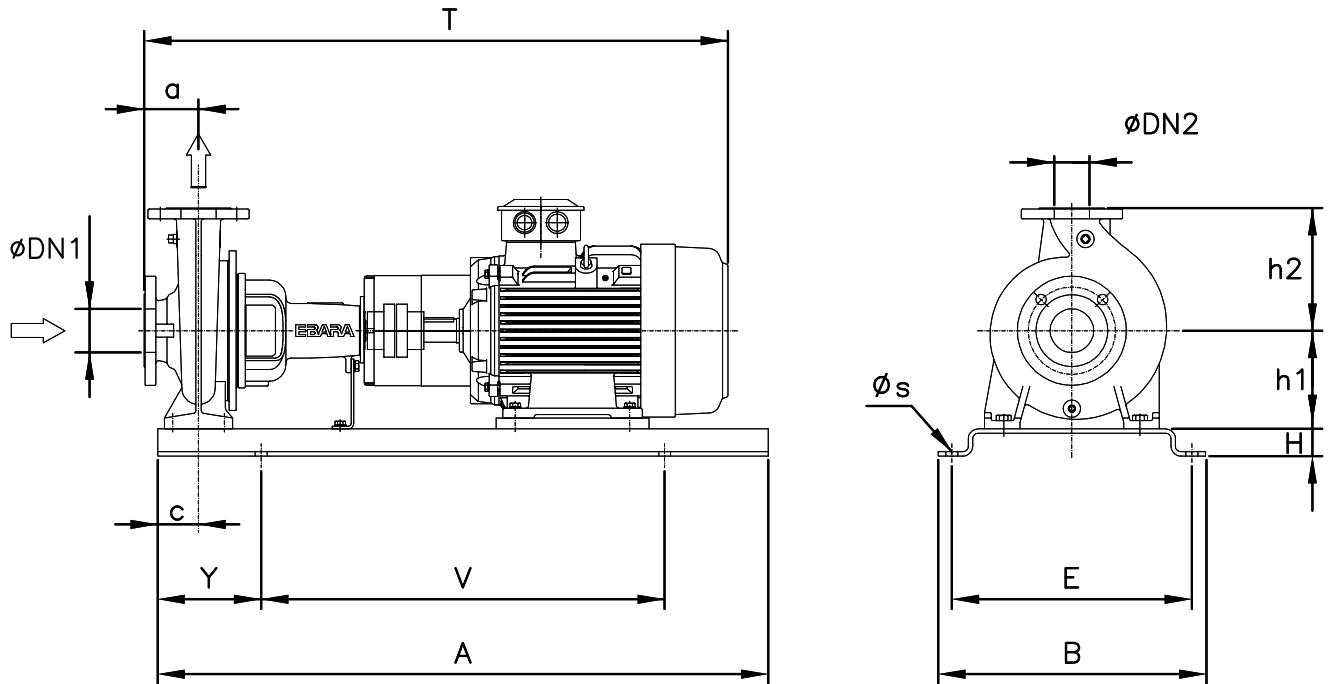

Total weight : 323 kg

Pump dimensions		mm	Suction side	mm	Discharge side	mm
a	100		A	185	A	150
A	1120		d	19	d	19
B	610		D1	145	D1	110
c	100		D2	118	D2	84
DN1	65		dn	65	dn	40
DN2	40		N	4(Num)	N	4(Num)
E	550		t	2	t	2
H	50		T	20	T	18
h1	180					
h2	225					
s	22					
T	1230					
V	740					
Y	190					

# Construction

Pump name GS2 40-250-260/B/30

Customer	Date 2024-06-14	Company
Contact	Item no.	Issued by
Phone	Project	Phone
E-mail	Project ID Proiect redenumit 2024-06-14 18:50:31	E-mail