

Technical Data

Pump Name

GS2 80-250-270/B/90

Customer	Date	2024-06-14	Company
Contact	Item no.		Issued by
Phone	Project		Phone
E-mail	Project ID	Proiect redenumit 2024-06-14 18:50:3	E-mail

Requested data

1	Pump type	End Suction Volute Pump	Fluid	Water
2	Number of pumps / Reserve	1 / 0	Liquid temperature	°C
3	Flow	m³/h	Kin. viscosity	mm²/s
4	Head	m	Vapour pressure	bar
5	Geodetic head	m	PH value	
6	Inlet pressure (pin)	bar	Density	kg/m³
7	Available system NPSH		Solids	Weight %
8	Ambient temperature	°C		

Pump

9	Pump Name	GS2 80-250-270/B/90	Frequency	Hz	50	
10	Design	End Suction Volute Pump	Installation type		with base, motor	
11	Manufacturer	EBARA	Impeller Diameter	Max.	mm	
12	Speed	rpm		2900	Designed	mm
13	No. of Stage	1		Min.	mm	220
14	Connection	Suction side	EN	PN16	Flow	
15	Connection	Discharge side	EN	PN16		Operating
16	Max Working Pressure	bar	16			m³/h
17	Shut-off head	bar	9.63	Head	Operating	
18	Total weight	kg	See the table of "Dimensions".		- (Qmax.)	m
19	Shaft power	kW			- (Qmin.)	m
20				Max. Shaft Power at max. impeller	kW	
21	Required pump NPSH	m		Efficiency	%	

Materials

22	Casing	Cast iron		
23	Impeller	Cast iron		
24	Shaft	Cr. Steel		
25	Case wear ring	Bronze		
26	O-ring	EPDM		
27	Mechanical seal	SiC/Carbon/EPDM		

Motor

28	Manufacturer	TECHTOP	Insulation class	F	
29	Type	280M_90_3_400	Phases	3~	
30	Specific design	TEFC/B3/IE3/TC / 50 Hz / Pole pairs 1	Frame size	280M_2P	
31	Rated power	kW	90	Weight	kg
32	Number of poles	2	Electric voltage	V	400
33	Speed	rpm	2940	Electric current	A
34	Degree of protection	IP55			
35					

Remarks

Performance Curve

Pump Name

GS2 80-250-270/B/90

Customer	Date	2024-06-14	Company
Contact	Item no.		Issued by
Phone	Project		Phone
E-mail	Project ID	Project redenumit 2024-06-14 18:50:31	E-mail

Requested data

1	Flow	m³/h	
2	Head	m	
3	Geodetic head	m	

Pump

Operating flow	m³/h		Frequency	Hz	50
Operating head	m		Number of poles		2
Impeller diameter designed	mm	270	Speed	rpm	2900

Test standard: ISO 9906:2012 - Grade3B

Water; 20°C; 998.3kg/m³; 1mm²/s

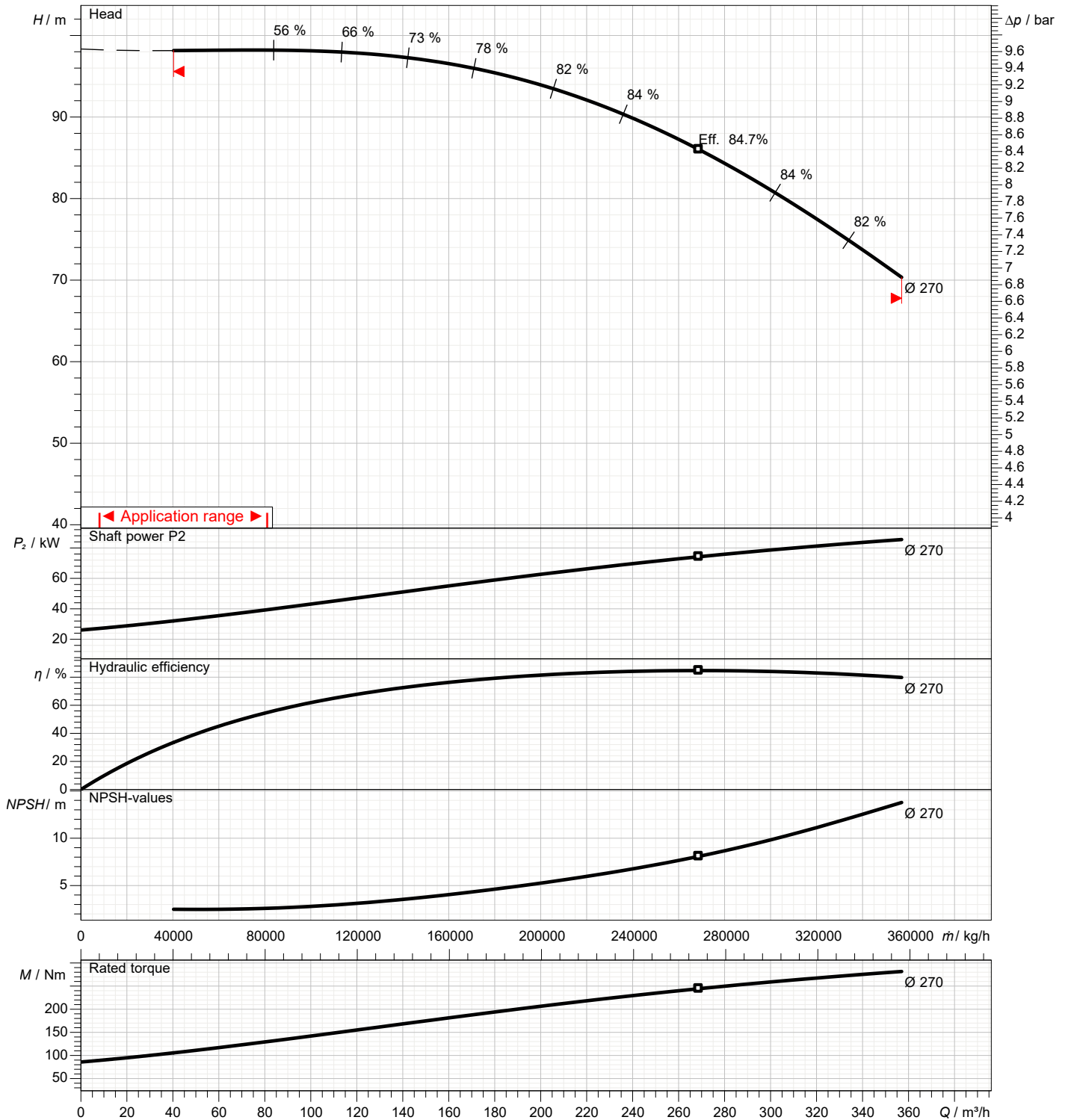

Dimensions

Pump name GS2 80-250-270/B/90

Customer	Date 2024-06-14	Company
Contact	Item no.	Issued by
Phone	Project	Phone
E-mail	Project ID Proiect redenumit 2024-06-14 18:50:31	E-mail

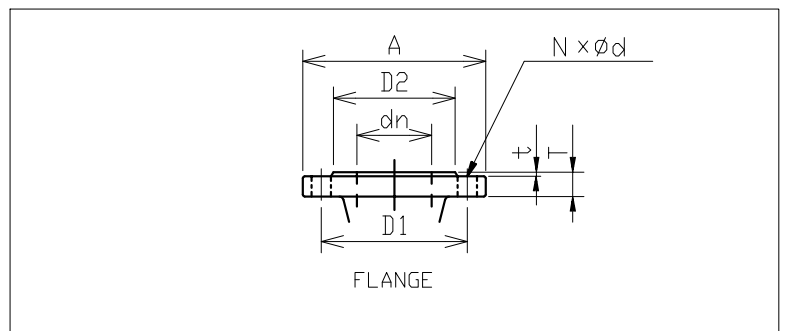
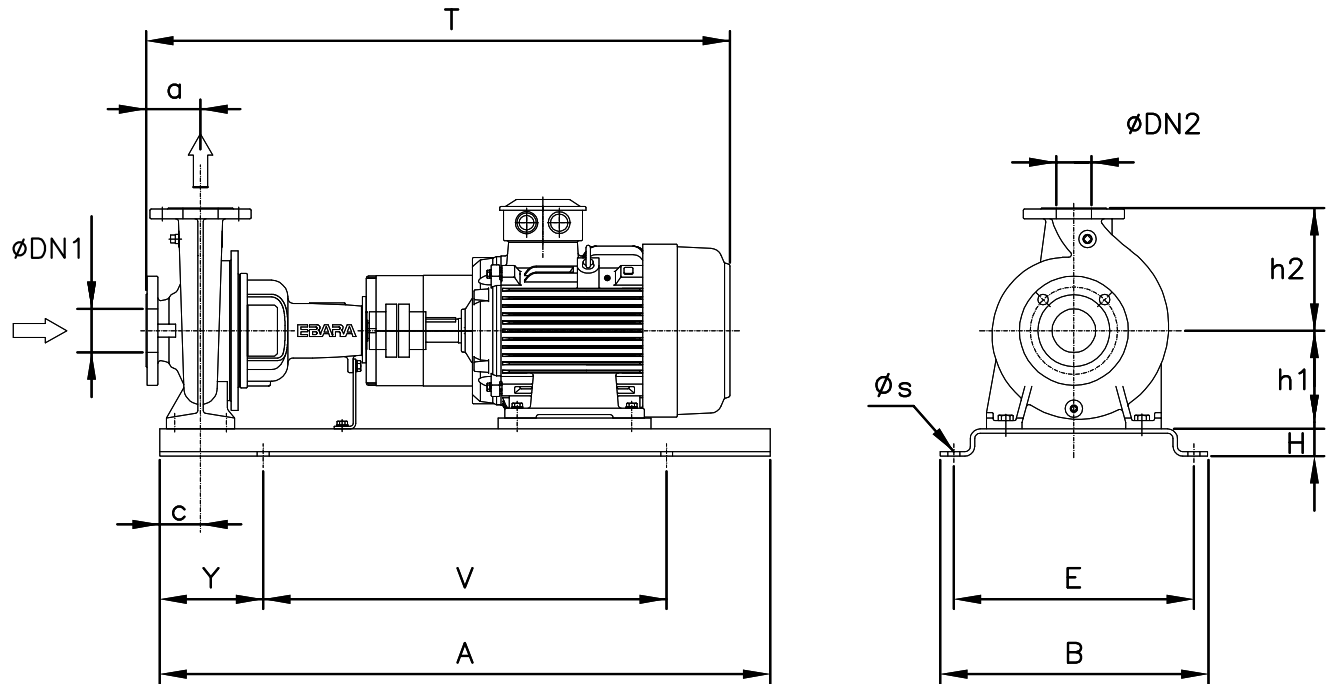

Total weight : 929 kg

Pump dimensions		mm	Suction side	mm	Discharge side	mm
a	125		A	220	A	200
A	1800		d	19	d	19
B	730		D1	180	D1	160
c	125		D2	156	D2	132
DN1	100		dn	100	dn	80
DN2	80		N	8(Num)	N	8(Num)
E	670		t	2	t	2
H	100		T	24	T	22
h1	200					
h2	280					
s	26					
T	1669					
V	1200					
Y	300					

Construction

Pump name GS2 80-250-270/B/90

Customer	Date 2024-06-14	Company
Contact	Item no.	Issued by
Phone	Project	Phone
E-mail	Project ID Proiect redenumit 2024-06-14 18:50:31	E-mail