

# Technical Data

Pump Name

GS4 200-500-530/M/315

Customer	Date	2024-06-14	Company
Contact	Item no.		Issued by
Phone	Project		Phone
E-mail	Project ID	Proiect redenumit 2024-06-14 18:50:3	E-mail

## Requested data

1	Pump type	End Suction Volute Pump	Fluid	Water
2	Number of pumps / Reserve	1 / 0	Liquid temperature	°C
3	Flow	m³/h	Kin. viscosity	mm²/s
4	Head	m	Vapour pressure	bar
5	Geodetic head	m	PH value	
6	Inlet pressure (pin)	bar	Density	kg/m³
7	Available system NPSH		Solids	Weight %
8	Ambient temperature	°C		

## Pump

9	Pump Name	GS4 200-500-530/M/315	Frequency	Hz	50	
10	Design	End Suction Volute Pump	Installation type	with fabricated base, motor		
11	Manufacturer	EBARA	Impeller Diameter	Max.	mm	
12	Speed	rpm		1450	Designed	mm
13	No. of Stage	1		Min.	mm	411
14	Connection	Suction side	EN	PN16	Flow	
15	Connection	Discharge side	EN	PN16		Operating
16	Max Working Pressure	bar	16	Max-		m³/h
17	Shut-off head	bar	9.40	Min-	m³/h	
18	Total weight	kg	See the table of "Dimensions".	Head	Operating	
19	Shaft power	kW			- (Qmax.)	m
20					- (Qmin.)	m
21	Required pump NPSH	m		Max. Shaft Power at max. impeller	kW	
				Efficiency	%	

## Materials

22	Casing	Cast iron		
23	Impeller	Ductile cast iron		
24	Shaft	Cr. Steel		
25	Case wear ring	Bronze		
26	O-ring	EPDM		
27	Mechanical seal	SiC/Carbon/EPDM		

## Motor

28	Manufacturer	TECHTOP	Insulation class	F	
29	Type	355L1_315_3_400	Phases	3~	
30	Specific design	TEFC/B3/IE3/TC / 50 Hz / Pole pairs 2	Frame size	355L1	
31	Rated power	kW	315	Weight	kg
32	Number of poles	4	Electric voltage	V	400
33	Speed	rpm	1480	Electric current	A
34	Degree of protection	IP55			
35					

## Remarks

# Performance Curve

Pump Name

GS4 200-500-530/M/315

Customer	Date	2024-06-14	Company
Contact	Item no.		Issued by
Phone	Project		Phone
E-mail	Project ID	Project redenumit 2024-06-14 18:50:31	E-mail

## Requested data

1	Flow	m³/h	
2	Head	m	
3	Geodetic head	m	

## Pump

Operating flow	m³/h		Frequency	Hz	50
Operating head	m		Number of poles		4
Impeller diameter designed	mm	530	Speed	rpm	1450

Test standard: ISO 9906:2012 - Grade3B

Water; 20°C; 998.3kg/m³; 1mm²/s

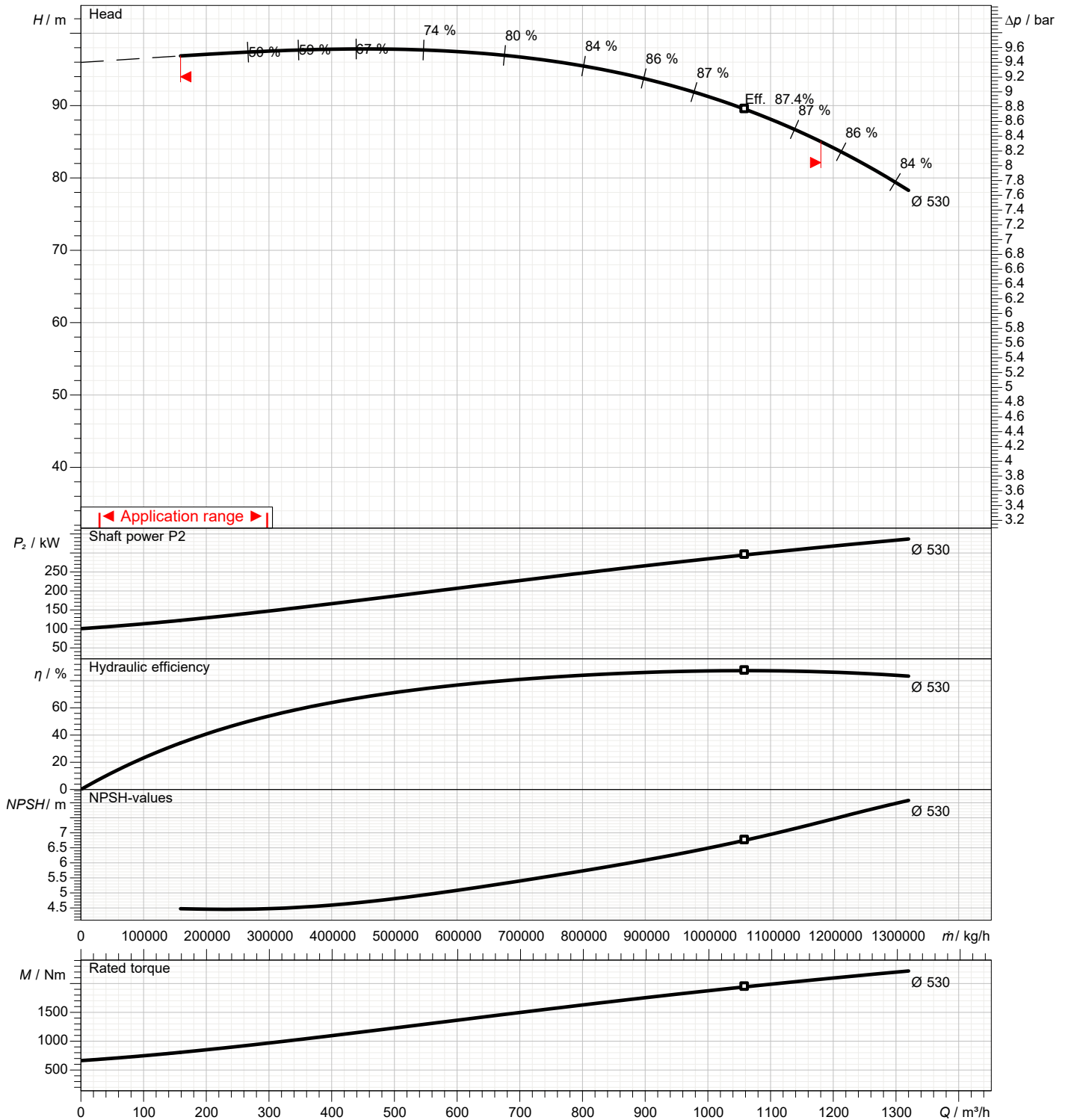

# Dimensions

Pump name GS4 200-500-530/M/315

Customer	Date 2024-06-14	Company
Contact	Item no.	Issued by
Phone	Project	Phone
E-mail	Project ID Proiect redenumit 2024-06-14 18:50:3	E-mail

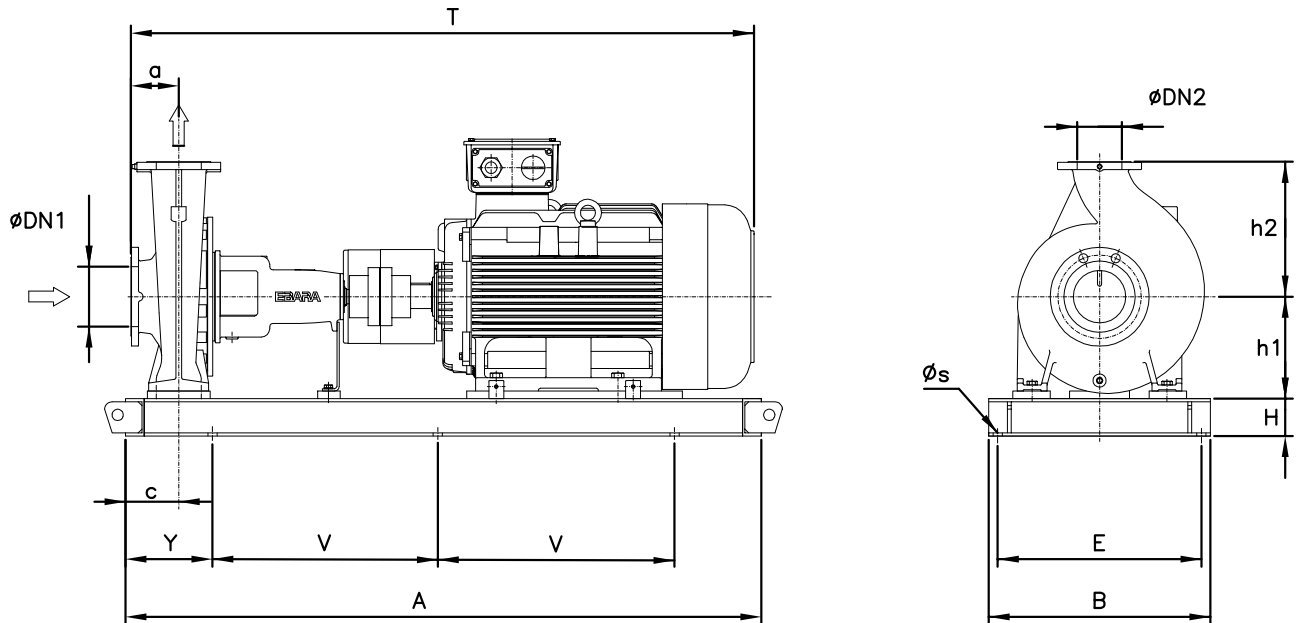

Total weight : 2638 kg

Pump dimensions		mm	Suction side	mm	Discharge side	mm
a	200		A	405	A	340
A	2400		d	28	d	23
B	870		D1	355	D1	295
c	315		D2	319	D2	266
DN1	250		dn	250	dn	200
DN2	200		N	12(Num)	N	12(Num)
E	810		t	2	t	2
H	160		T	32	T	30
h1	435					
h2	630					
s	20					
T	2505					
V	950					
Y	250					

# Construction

Pump name GS4 200-500-530/M/315

Customer	Date 2024-06-14	Company
Contact	Item no.	Issued by
Phone	Project	Phone
E-mail	Project ID Project redenumit 2024-06-14 18:50:31	E-mail