

# Technical data

Pump name

GSD2 32-160.1/B1/A 3

Customer	Date	2024-06-16	Company
Contact	Item no.		Issued by
Phone	Project		Phone
E-mail	Project ID	Proiect redenumit 2024-06-16 12:31:28.:	E-mail

## Requested data

1	Pump type	End Suction Volute Pump	Fluid	Water
2	Number of pumps / Reserve	1 / 0	Liquid temperature	°C 20
3	Flow	m³/h	Kin. viscosity	mm²/s 1.005
4	Head	m	Vapour pressure	bar 0.0234
5	Geodetic head	m	PH value	
6	Inlet pressure (pin)	bar 0	Density	kg/m³ 998.3
7	Available system NPSH		Solids	Weight % 0
8	Ambient temperature	°C 20		

## Pump

9	Pump name	GSD2 32-160.1/B1/A 3	Frequency	Hz 50
10	Item number	2697001004	Installation type	Standard (without base)
11	Design	End Suction Volute Pump	Impeller Diameter	Max. mm 152
12	Manufacturer	EBARA		Designed mm 152
13	Speed	rpm 2890		Min. mm 152
14	No. of Stage	1	Flow	Operating m³/h
15	Connection Suction side	EN 1092-1 PN16		Max- m³/h 28.9
16	Connection Discharge side	EN 1092-1 PN16		Min- m³/h 3.55
17	Max Working Pressure	bar 16	Head	Operating m
18	Shut-off head	bar 2.89		- (Qmax.) m 22.7
19	Total weight	kg See the table of "Dimensions".		- (Qmin.) m 29.8
20	Shaft power	kW	Max. Shaft Power at max. impeller	kW 2.88
21	Required pump NPSH	m	Efficiency	%

## Materials

22	Impeller	Cast iron	
23	Casing	Cast iron	
24	Shaft (wet extension)	AISI 420	
25	Liner ring	Bronze	
26	O-ring	EPDM	
27			

## Motor

28	Manufacturer	FELM	Insulation class	F
29	Type	100L_B5_3_3_400_2	Phases	3~
30	Specific design	IE3 / 50 Hz / Pole pairs 1	Frame size	100L
31	Rated power	kW 3	Weight	kg 25
32	Number of poles	2	Electric voltage	V 400
33	Speed	rpm 2850	Electric current	A 5.72
34	Degree of protection	IP55		
35				

## Remarks

# Performance curve

Pump name

GSD2 32-160.1/B1/A 3

Customer	Date	2024-06-16	Company
Contact	Item no.		Issued by
Phone	Project		Phone
E-mail	Project ID	Proiect redenumit 2024-06-16 12:31:28.;	E-mail

## Requested data

1	Flow	m³/h	
2	Head	m	
3	Geodetic head	m	

## Pump

Operating flow	m³/h		Frequency	Hz	50
Operating head	m		Number of poles		2
ImpellerDiameter Designed	mm	152	Speed	rpm	2850

Test standard: ISO 9906:2012 - Grade3B

Water; 20°C; 998.3kg/m³; 1mm²/s

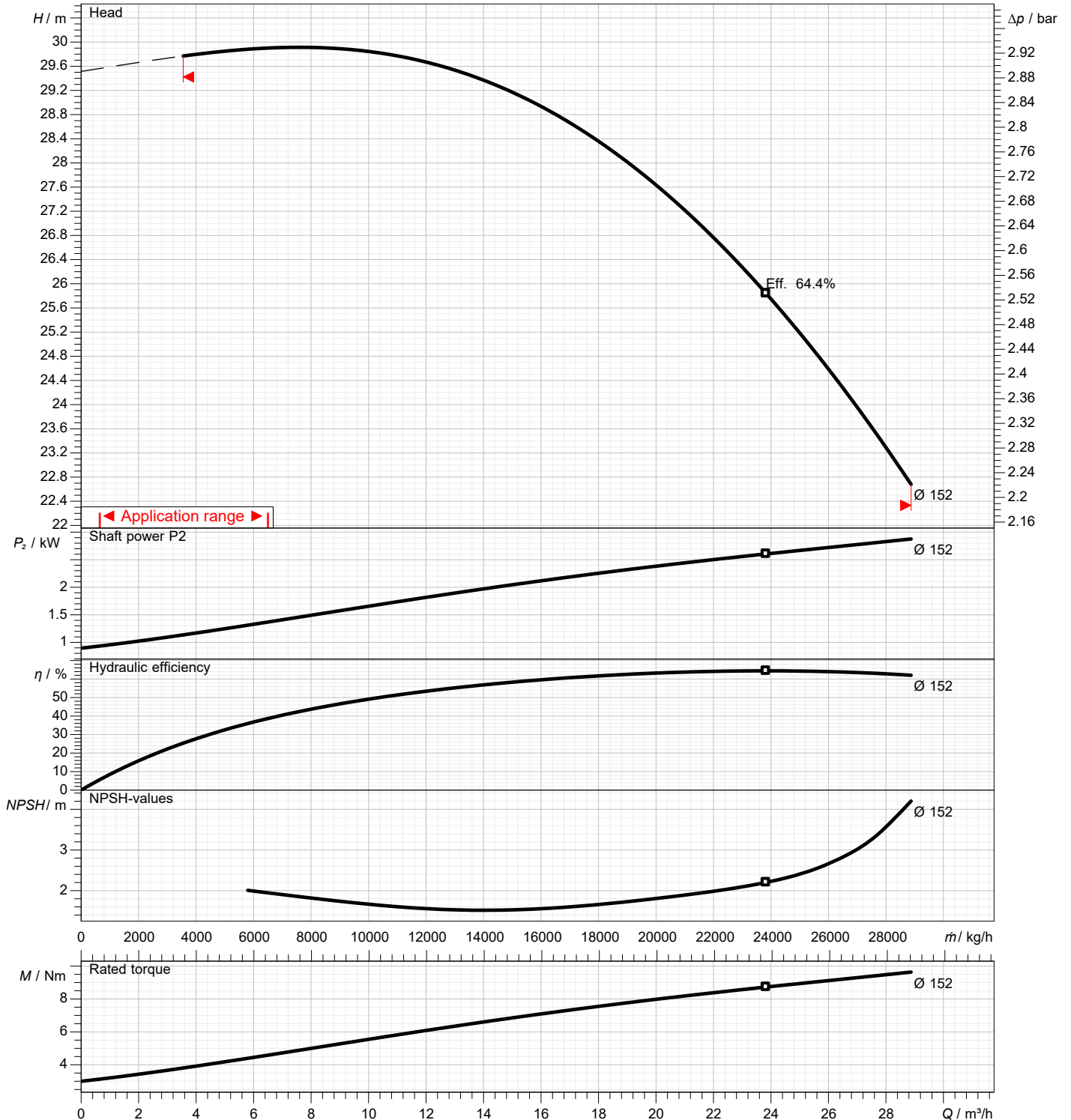

# Dimensions

Pump name GSD2 32-160.1/B1/A 3

Customer	Date 2024-06-16	Company
Contact	Item no.	Issued by
Phone	Project	Phone
E-mail	Project ID Proiect redenumit 2024-06-16 12:31:28.:	E-mail

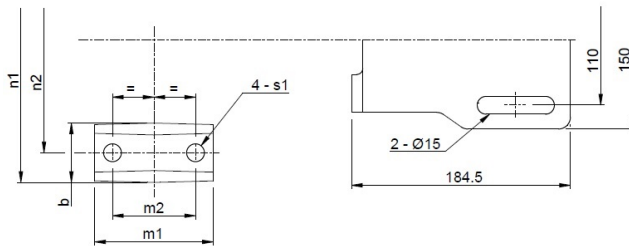
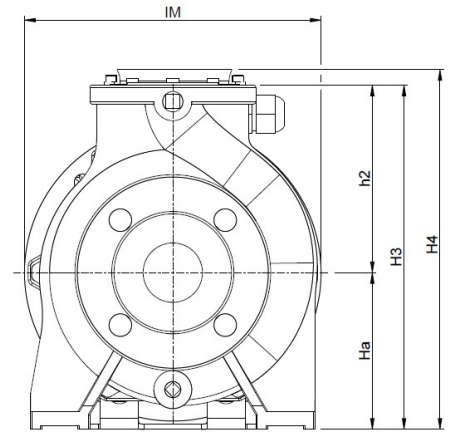

EN 1092-1 PN16

Pump dimensions		mm		Suction side		mm		Discharge side		mm	
a	80	s1	15	A	165	A	140				
b	50	T	578	d	19	d	19				
DN1	50	Weight kg	53	D1	125	D1	100				
DN2	32			D2	99	D2	76				
h2	160			DN	50	DN	32				
H3	292			N	4(Num)	N	4(Num)				
H4	292			T	20	T	18				
Ha	132										
IM	250										
m1	100										
m2	70										
n1	240										
n2	190										
P3	305										
P4	401										

(1/2)

# Construction

Pump name GSD2 32-160.1/B1/A 3

Customer	Date 2024-06-16	Company
Contact	Item no.	Issued by
Phone	Project	Phone
E-mail	Project ID Proiect redenumit 2024-06-16 12:31:28.;	E-mail

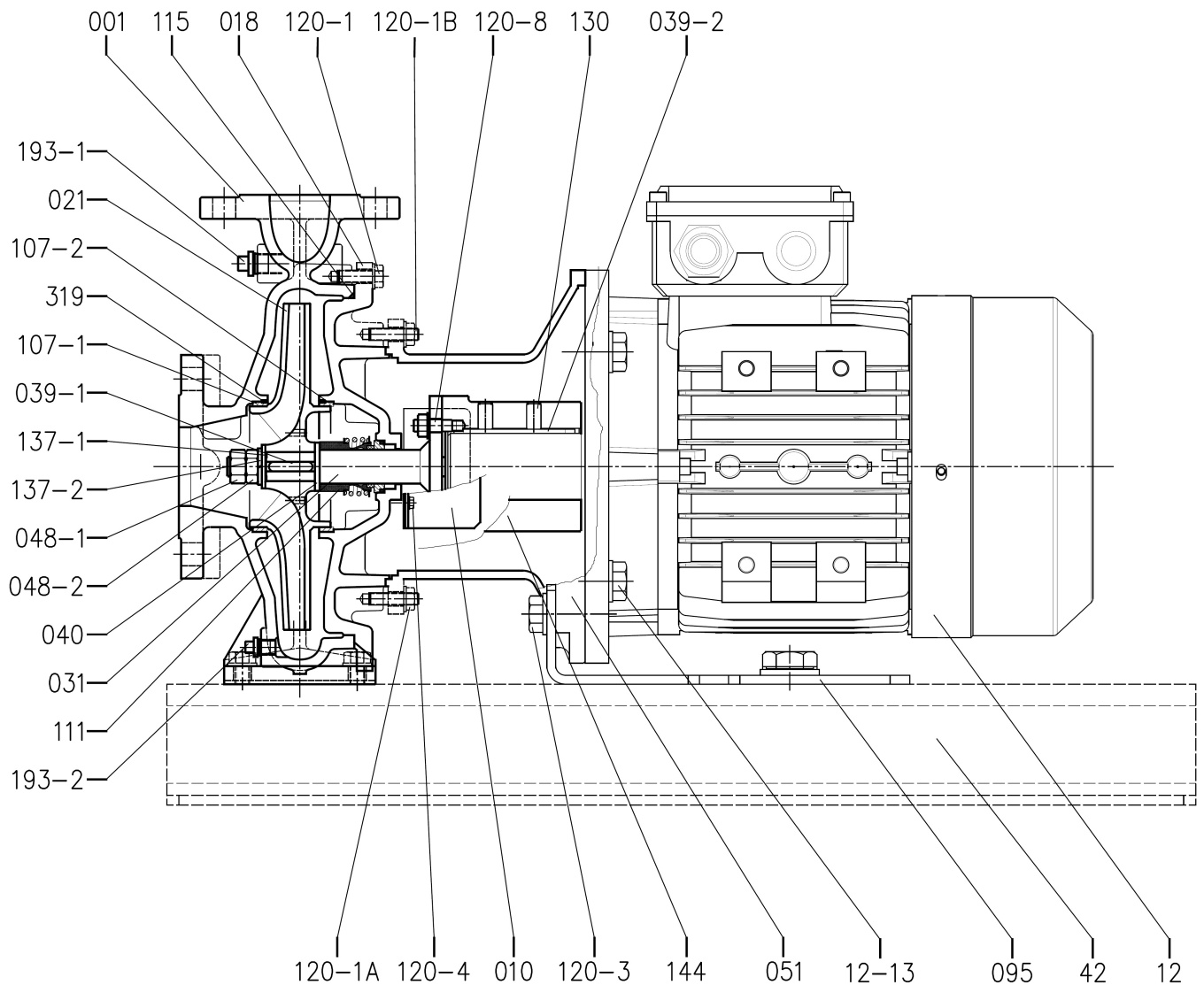

(2/2)

# Construction

Pump name GSD2 32-160.1/B1/A 3

Customer	Date 2024-06-16	Company
Contact	Item no.	Issued by
Phone	Project	Phone
E-mail	Project ID Project redenumit 2024-06-16 12:31:28.:	E-mail

## SECTIONAL VIEW TABLE

No.	Part name	Materials	ISO or EN equivalent	Q.ty
001	Casing	Cast iron	EN-GJL-250(EN-JL1040)	1
010	Protector	Carbon steel	DC01(1.0330)	1
014	Inspection cover [1]	Cast iron	EN-GJL-250(EN-JL1040)	1
018	Casing cover	Cast iron	EN-GJL-250(EN-JL1040)	1
021	Impeller	Cast iron	EN-GJL-200(EN-JL1030)	1
		Ductile cast iron [2]	EN-GJS-400-15(5.3106)	
		Bronze [3]	CuSn5Zn5Pb5(CC491K)	
031	Shaft	Martensitic stainless steel / Carbon steel	X30Cr13(1.4028) / C35	1
039-1	Key	Martensitic stainless steel	X30Cr13(1.4028)	1
039-2	Key	Carbon steel	C50(1.0540)	1
040	Mechanical seal sleeve	Austenitic stainless steel	X5CrNi18-10(1.4301)	1
048-1	Impeller nut (A)	Austenitic stainless steel	X5CrNi18-10(1.4301)	1
048-2	Impeller nut (B)	Austenitic stainless steel	X5CrNi18-10(1.4301)	1
051	Bracket	Cast iron	EN-GJL-250(EN-JL1040)	1
095	Stay [4]	Carbon steel	DC01(1.0327)	1
107-1	Casing Ring	Copper alloy	CuSn5Zn5Pb5(CC491K)	1
107-2	Casing Ring	Copper alloy	CuSn5Zn5Pb5(CC491K)	1
111	Mechanical Seal	Sic/Carbon/EPDM	---	1
		Sic/Carbon/FPM	---	
115	O-Ring	EPDM	---	1
		FPM	---	
117-2	Gasket [1]	PTFE fiber	---	1
120-1	Screw with plan washer	Steel+Trivalent chromate	S275JR (1.0044)	[5]
120-1A	Stud Bolt with plan washer	Steel+Trivalent chromate	S275JR (1.0044)	[7]
120-1B	Stud Bolt with plan washer	Steel+Trivalent chromate	S275JR (1.0044)	2
120-2	Screw with plan washer	Steel+Trivalent chromate	S275JR (1.0044)	6
120-3	Screw with plan washer	Steel+Trivalent chromate	S275JR (1.0044)	2
120-4	Screw with plan washer	Steel+Trivalent chromate	S275JR (1.0044)	4
120-6	Screw with plan washer	Steel+Trivalent chromate	S275JR (1.0044)	6
120-8	Stud Bolt (with spring & plan washer)	Steel+Trivalent chromate	AISI4135/C45/SS	4
130	Set screw	Carbon Steel 45H	---	2
144	Hub	Carbon Steel	C35	1
137-1	Plan Washer	304 Stainless steel	X5CrNi18-10(1.4301)	1
137-2	Spring Lock Washer	304 Stainless steel	X5CrNi18-10(1.4301)	1
193-1	Air vent Plug	Steel+Trivalent chromate	S275JR (1.0044)	1
193-2	Drain Plug	Steel+Trivalent chromate	S275JR (1.0044)	1
193-3	Air vent Plug [1]	Steel+Trivalent chromate	S275JR (1.0044)	1
319	Pin	Stainless steel	---	2
12	Motor	---	---	1
12-13	Bolt with plan washer or Screw [11]	Galvanized Steel 8.8 strength class ISO 898/1	---	4
42	Base [8]	Galvanized steel	S235	1
50-01	Motor spacer	Galvanized steel	S235	[9]
50-02	Pump spacer	Galvanized steel	S235	[10]

- [1] Only for pump size 150-400
- [2] Only for pump size 100-400; 125-400; 150-400
- [3] For for models with Bronze impeller
- [4] Only for pump with motor up to 7,5kW
- [5] no.8 pcs for pump size 32-200.1 80-200 100-200 125-200 150-200 ; no.10 pcs for pump size 32-250 40-250 50-250 65-250 80-250 100-250 125-250 ; no.12 pcs for pump size 40-315 50-315 65-315 80-315 100-315 ; no.16 pcs for size 80-100 100-400 125-400 150-400
- [6] Only for pump size 32-125.1 and 32-160.1
- [7] Only for pump size 32-125.1 no.4 pcs ; size 32-160.1 no.6 pcs
- [8] Only for pump with base version
- [9] no.0-1-2 pcs Depend of the model see drawings
- [10] no.0-1-2 pcs Depend of the model see drawings
- [11] Screw for model GSD2 32-125.1/1.5, GSD2 32-125.1/2.2, GSD2 32-160.1/2.2, GSD4 32-250/1.1, GSD4 32-250/1.5, GSD4 80-160/1.5

# Shaft seal

Pump name GSD2 32-160.1/B1/A 3

Customer	Date 2024-06-16	Company
Contact	Item no.	Issued by
Phone	Project	Phone
E-mail	Project ID Proiect redenumit 2024-06-16 12:31:28.:	E-mail

Dimensions	Value / mm
d1	28
d6	37
d7	43
da	49
L1N	50
L2	42.5



Liquid temperature	Liquid	Rotating part	Fixed part	Elastomers	Spring
-10 to 120 °C	Clean water, hot water, water with glicole (30%)	Silicon carbide (Q1)	Carbon graphite resin impregnated (B)	Ethylene propylene rubber - EPDM (E)	AISI 316 (G)