

Technical data

Pump name

GSD4 80-160/B1/A 2.2

Customer	Date	2024-06-16	Company
Contact	Item no.		Issued by
Phone	Project		Phone
E-mail	Project ID	Proiect redenumit 2024-06-16 12:31:28.:	E-mail

Requested data

1	Pump type	End Suction Volute Pump	Fluid	Water
2	Number of pumps / Reserve	1 / 0	Liquid temperature	°C 20
3	Flow	m³/h	Kin. viscosity	mm²/s 1.005
4	Head	m	Vapour pressure	bar 0.0234
5	Geodetic head	m	PH value	
6	Inlet pressure (pin)	bar 0	Density	kg/m³ 998.3
7	Available system NPSH		Solids	Weight % 0
8	Ambient temperature	°C 20		

Pump

9	Pump name	GSD4 80-160/B1/A 2.2	Frequency	Hz 50
10	Item number	2698001022	Installation type	Standard (without base)
11	Design	End Suction Volute Pump	Impeller Diameter	Max. mm 162
12	Manufacturer	EBARA		Designed mm 162
13	Speed	rpm 1435		Min. mm 162
14	No. of Stage	1	Flow	Operating m³/h
15	Connection Suction side	EN 1092-1 PN16		Max- m³/h 131
16	Connection Discharge side	EN 1092-1 PN16		Min- m³/h 14.6
17	Max Working Pressure	bar 16	Head	Operating m
18	Shut-off head	bar 0.79		- (Qmax.) m 4.4
19	Total weight	kg See the table of "Dimensions".		- (Qmin.) m 7.9
20	Shaft power	kW	Max. Shaft Power at max. impeller	kW 2.18
21	Required pump NPSH	m	Efficiency	%

Materials

22	Impeller	Cast iron		
23	Casing	Cast iron		
24	Shaft (wet extension)	AISI 420		
25	Liner ring	Bronze		
26	O-ring	EPDM		
27				

Motor

28	Manufacturer	FELM	Insulation class	F
29	Type	100L_B5_2.2_3_400_4	Phases	3~
30	Specific design	IE3 / 50 Hz / Pole pairs 2	Frame size	100L
31	Rated power	kW 2.2	Weight	kg 26
32	Number of poles	4	Electric voltage	V 400
33	Speed	rpm 1440	Electric current	A 4.62
34	Degree of protection	IP55		
35				

Remarks

Performance curve

Pump name

GSD4 80-160/B1/A 2.2

Customer	Date	2024-06-16	Company
Contact	Item no.		Issued by
Phone	Project		Phone
E-mail	Project ID	Proiect redenumit 2024-06-16 12:31:28.;	E-mail

Requested data

1	Flow	m³/h	
2	Head	m	
3	Geodetic head	m	

Pump

Operating flow	m³/h		Frequency	Hz	50
Operating head	m		Number of poles		4
ImpellerDiameter Designed	mm	162	Speed	rpm	1440

Test standard: ISO 9906:2012 - Grade3B

Water; 20°C; 998.3kg/m³; 1mm²/s

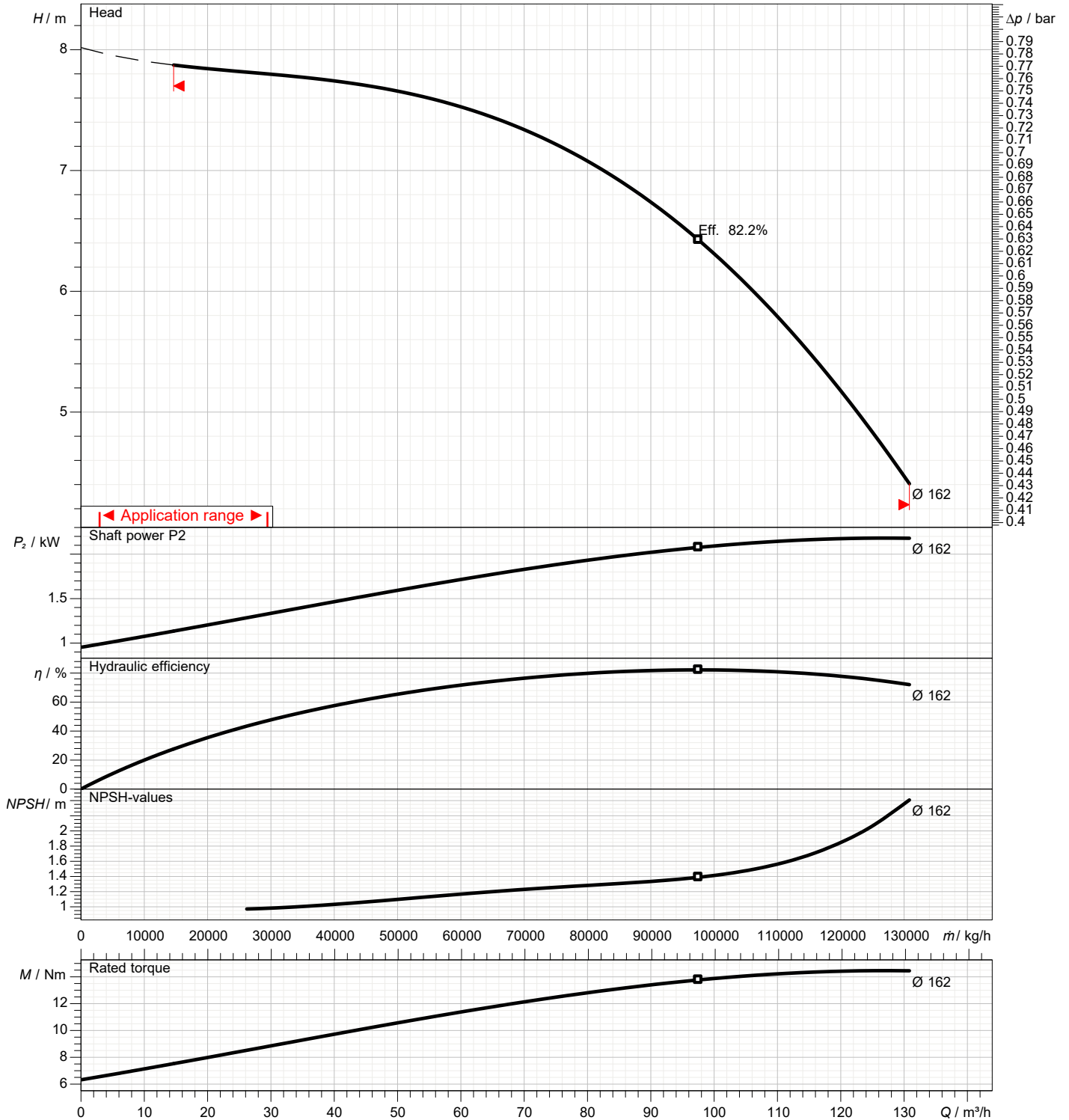

Dimensions

Pump name GSD4 80-160/B1/A 2.2

Customer	Date 2024-06-16	Company
Contact	Item no.	Issued by
Phone	Project	Phone
E-mail	Project ID Proiect redenumit 2024-06-16 12:31:28.:	E-mail

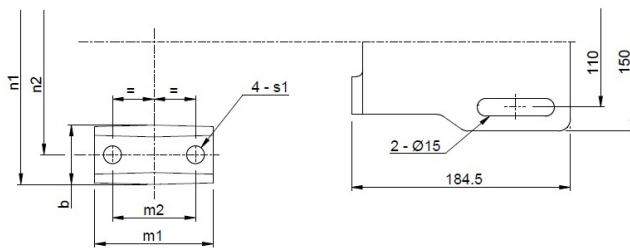
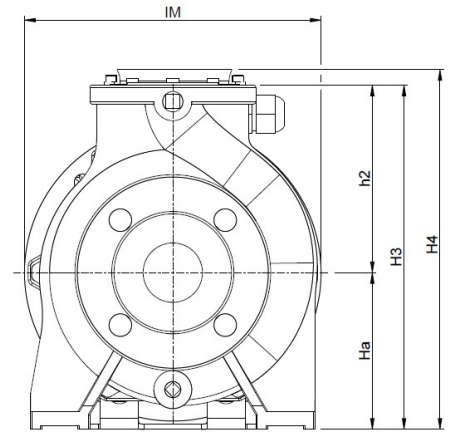

EN 1092-1 PN16

Pump dimensions		mm		Suction side		mm		Discharge side		mm	
a	125	s1	15	A	220	A	200				
b	65	T	623	d	19	d	19				
DN1	100	Weight kg	75	D1	180	D1	160				
DN2	80			D2	156	D2	132				
h2	225			DN	100	DN	80				
H3	405			N	8(Num)	N	8(Num)				
H4	405			T	24	T	22				
Ha	180										
IM	354										
m1	125										
m2	95										
n1	320										
n2	250										
P3	305										
P4	413.5										

(1/2)

Construction

Pump name GSD4 80-160/B1/A 2.2

Customer	Date 2024-06-16	Company
Contact	Item no.	Issued by
Phone	Project	Phone
E-mail	Project ID Proiect redenumit 2024-06-16 12:31:28.;	E-mail

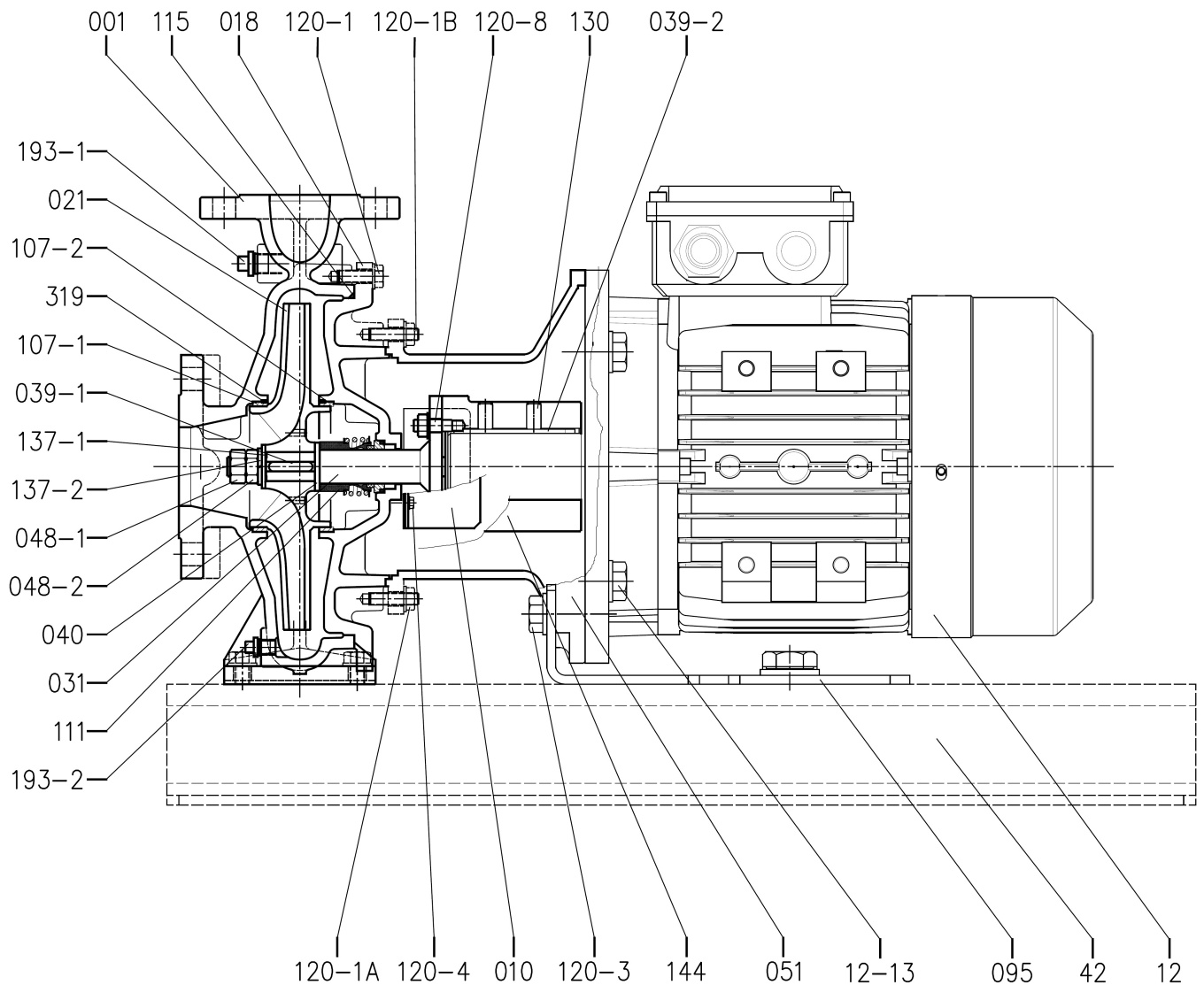

(2/2)

Construction

Pump name GSD4 80-160/B1/A 2.2

Customer	Date 2024-06-16	Company
Contact	Item no.	Issued by
Phone	Project	Phone
E-mail	Project ID Project redenumit 2024-06-16 12:31:28.:	E-mail

SECTIONAL VIEW TABLE

No.	Part name	Materials	ISO or EN equivalent	Q.ty
001	Casing	Cast iron	EN-GJL-250(EN-JL1040)	1
010	Protector	Carbon steel	DC01(1.0330)	1
014	Inspection cover [1]	Cast iron	EN-GJL-250(EN-JL1040)	1
018	Casing cover	Cast iron	EN-GJL-250(EN-JL1040)	1
021	Impeller	Cast iron	EN-GJL-200(EN-JL1030)	1
		Ductile cast iron [2]	EN-GJS-400-15(5.3106)	
		Bronze [3]	CuSn5Zn5Pb5(CC491K)	
031	Shaft	Martensitic stainless steel / Carbon steel	X30Cr13(1.4028) / C35	1
039-1	Key	Martensitic stainless steel	X30Cr13(1.4028)	1
039-2	Key	Carbon steel	C50(1.0540)	1
040	Mechanical seal sleeve	Austenitic stainless steel	X5CrNi18-10(1.4301)	1
048-1	Impeller nut (A)	Austenitic stainless steel	X5CrNi18-10(1.4301)	1
048-2	Impeller nut (B)	Austenitic stainless steel	X5CrNi18-10(1.4301)	1
051	Bracket	Cast iron	EN-GJL-250(EN-JL1040)	1
095	Stay [4]	Carbon steel	DC01(1.0327)	1
107-1	Casing Ring	Copper alloy	CuSn5Zn5Pb5(CC491K)	1
107-2	Casing Ring	Copper alloy	CuSn5Zn5Pb5(CC491K)	1
111	Mechanical Seal	Sic/Carbon/EPDM	---	1
		Sic/Carbon/FPM	---	
115	O-Ring	EPDM	---	1
		FPM	---	
117-2	Gasket [1]	PTFE fiber	---	1
120-1	Screw with plan washer	Steel+Trivalent chromate	S275JR (1.0044)	[5]
120-1A	Stud Bolt with plan washer	Steel+Trivalent chromate	S275JR (1.0044)	[7]
120-1B	Stud Bolt with plan washer	Steel+Trivalent chromate	S275JR (1.0044)	2
120-2	Screw with plan washer	Steel+Trivalent chromate	S275JR (1.0044)	6
120-3	Screw with plan washer	Steel+Trivalent chromate	S275JR (1.0044)	2
120-4	Screw with plan washer	Steel+Trivalent chromate	S275JR (1.0044)	4
120-6	Screw with plan washer	Steel+Trivalent chromate	S275JR (1.0044)	6
120-8	Stud Bolt (with spring & plan washer)	Steel+Trivalent chromate	AISI4135/C45/SS	4
130	Set screw	Carbon Steel 45H	---	2
144	Hub	Carbon Steel	C35	1
137-1	Plan Washer	304 Stainless steel	X5CrNi18-10(1.4301)	1
137-2	Spring Lock Washer	304 Stainless steel	X5CrNi18-10(1.4301)	1
193-1	Air vent Plug	Steel+Trivalent chromate	S275JR (1.0044)	1
193-2	Drain Plug	Steel+Trivalent chromate	S275JR (1.0044)	1
193-3	Air vent Plug [1]	Steel+Trivalent chromate	S275JR (1.0044)	1
319	Pin	Stainless steel	---	2
12	Motor	---	---	1
12-13	Bolt with plan washer or Screw [11]	Galvanized Steel 8.8 strength class ISO 898/1	---	4
42	Base [8]	Galvanized steel	S235	1
50-01	Motor spacer	Galvanized steel	S235	[9]
50-02	Pump spacer	Galvanized steel	S235	[10]

[1] Only for pump size 150-400
 [2] Only for pump size 100-400; 125-400; 150-400
 [3] For for models with Bronze impeller
 [4] Only for pump with motor up to 7,5kW
 [5] no.8 pcs for pump size 32-200.1 80-200 100-200 125-200 150-200 ; no.10 pcs for pump size 32-250 40-250 50-250 65-250 80-250 100-250 125-250 ; no.12 pcs for pump size 40-315 50-315 65-315 80-315 100-315 ; no.16 pcs for size 80-100 100-400 125-400 150-400
 [6] Only for pump size 32-125.1 and 32-160.1
 [7] Only for pump size 32-125.1 no.4 pcs ; size 32-160.1 no.6 pcs
 [8] Only for pump with base version
 [9] no.0-1-2 pcs Depend of the model see drawings
 [10] no.0-1-2 pcs Depend of the model see drawings
 [11] Screw for model GSD2 32-125.1/1.5, GSD2 32-125.1/2.2, GSD2 32-160.1/2.2, GSD4 32-250/1.1, GSD4 32-250/1.5, GSD4 80-160/1.5

Shaft seal

Pump name GSD4 80-160/B1/A 2.2

Customer	Date 2024-06-16	Company
Contact	Item no.	Issued by
Phone	Project	Phone
E-mail	Project ID Proiect redenumit 2024-06-16 12:31:28.:	E-mail

Dimensions	Value / mm
d1	28
d6	37
d7	43
da	49
L1N	50
L2	42.5



Liquid temperature	Liquid	Rotating part	Fixed part	Elastomers	Spring
-10 to 120 °C	Clean water, hot water, water with glicole (30%)	Silicon carbide (Q1)	Carbon graphite resin impregnated (B)	Ethylene propylene rubber - EPDM (E)	AISI 316 (G)