

Technical Data

Pump Name

GSS 32-200 /1.5

Customer	Date	2024-06-16	Company
Contact	Item no.		Issued by
Phone	Project		Phone
E-mail	Project ID	Proiect redenumit 2024-06-16 12:31:28	E-mail

Requested data

1	Pump type	End Suction Volute Pump	Fluid	Water
2	Number of pumps / Reserve	1 / 0	Liquid temperature	°C
3	Flow	m³/h	Kin. viscosity	mm²/s
4	Head	m	Vapour pressure	bar
5	Geodetic head	m	PH value	
6	Inlet pressure (pin)	bar	Density	kg/m³
7	Available system NPSH		Solids	Weight %
8	Ambient temperature	°C		

Pump

9	Pump Name	GSS 32-200 /1.5	Frequency	Hz	50	
10	Design	End Suction Volute Pump	Installation type	with ISO base, motor		
11	Manufacturer	EBARA	Impeller Diameter	Max.	mm	
12	Speed	rpm		1450	Designed	mm
13	No. of Stage	1		Min.	mm	177
14	Connection	Suction side	EN	PN16	Flow	
15	Connection	Discharge side	EN	PN16		
16	Max Working Pressure	bar	16			
17	Shut-off head	bar	1.52	Head	Operating	m
18	Total weight	kg	See the table of "Dimensions".		- (Qmax.)	m
19	Shaft power	kW			- (Qmin.)	m
20				Max. Shaft Power at max. impeller	kW	1.18
21	Required pump NPSH	m		Efficiency	%	

Materials

22	Casing	SCS13		
23	Impeller	SCS13		
24	Shaft	SUS329J3L/S35C		
25	Case wear ring	SUS316		
26	O-ring	FKM		
27	Mechanical Seal	SiC/Carbon/FKM		

Motor

28	Manufacturer	EBARA Standard	Insulation class	F	
29	Type	90L_1.5_3_380	Phases	3~	
30	Specific design	TEFC/B3/AESV1S / 50 Hz / Pole pairs 2	Frame size	90L	
31	Rated power	kW	1.5	Weight	kg
32	Number of poles	4		Electric voltage	V
33	Speed	rpm	1425	Electric current	A
34	Degree of protection	IP55			
35					

Remarks

Performance Curve

Pump Name

GSS 32-200 /1.5

Customer	Date	2024-06-16	Company
Contact	Item no.		Issued by
Phone	Project		Phone
E-mail	Project ID	Proiect redenumit 2024-06-16 12:31:28	E-mail

Requested data

1	Flow	m³/h	
2	Head	m	
3	Geodetic head	m	

Pump

Operating flow	m³/h		Frequency	Hz	50
Operating head	m		Number of poles		4
Impeller diameter designed	mm	219	Speed	rpm	1450

Test standard: ISO 9906:2012 - Grade3B

Water; 20°C; 998.3kg/m³; 1mm²/s

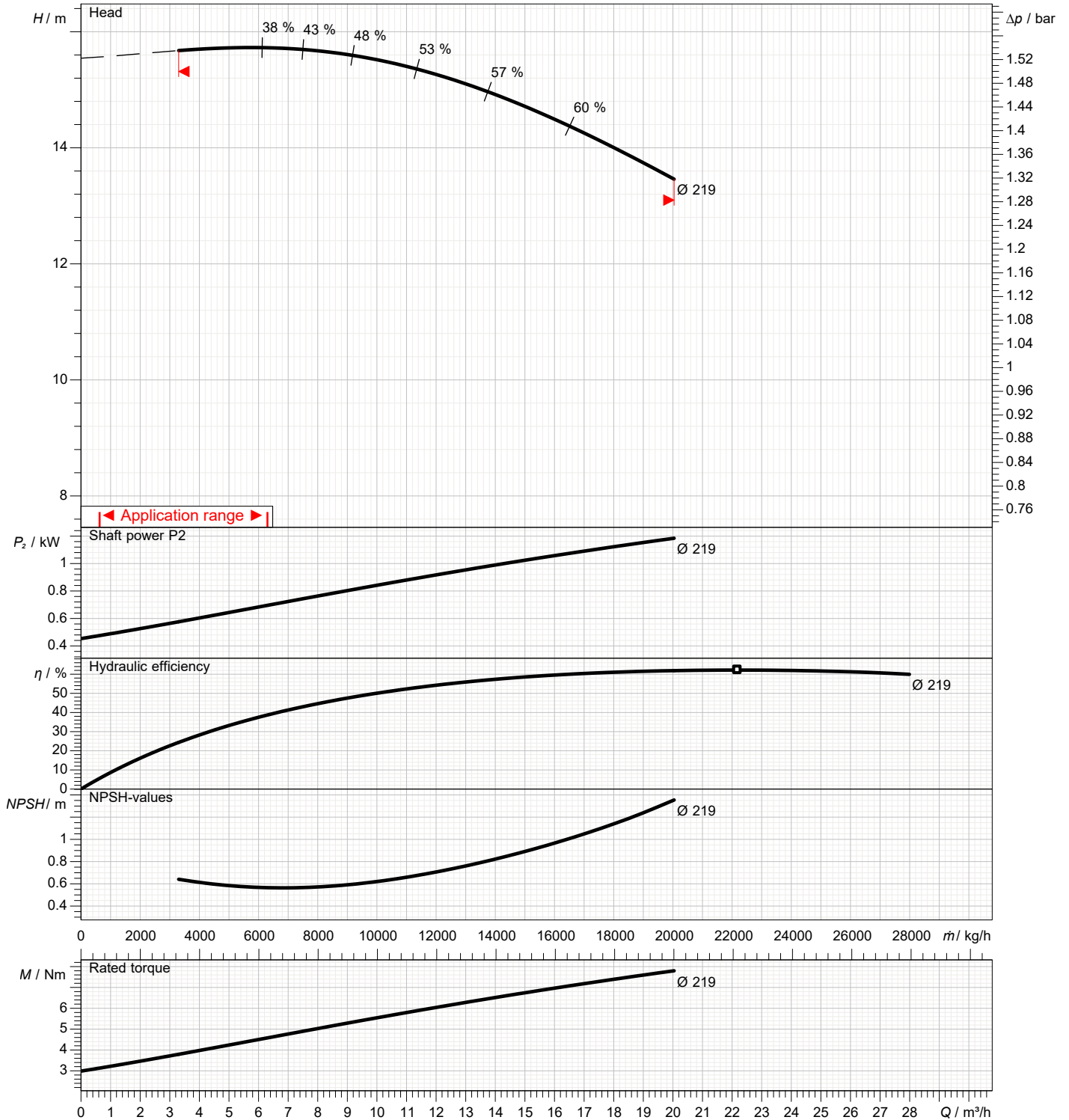

Dimensions

Pump name GSS 32-200 /1.5

Customer	Date 2024-06-16	Company
Contact	Item no.	Issued by
Phone	Project	Phone
E-mail	Project ID Proiect redenumit 2024-06-16 12:31:28	E-mail



This base is not necessary to grout.
Special base can be provided for grouting.

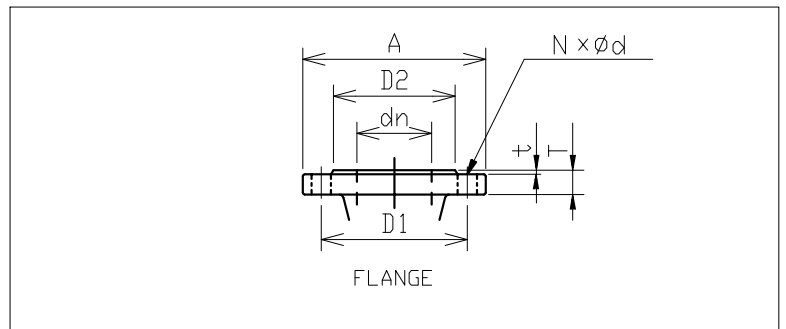

Total weight : 99 kg

Pump dimensions		mm	Suction side	mm	Discharge side	mm
a	80		A	165	A	140
BJ	60		d	18	d	18
BM1	540		D1	125	D1	100
BN1	130		D2	102	D2	78
BN2	130		dn	50	dn	32
BW	390		N	4(Num)	N	4(Num)
BY	350		t	2	t	2
dn1	50		T	18	T	18
dn2	32					
h1	210					
h2	180					
L	812					
nxFd	4xM16					

Construction

Pump name GSS 32-200 /1.5

Customer	Date 2024-06-16	Company
Contact	Item no.	Issued by
Phone	Project	Phone
E-mail	Project ID Proiect redenumit 2024-06-16 12:31:28	E-mail

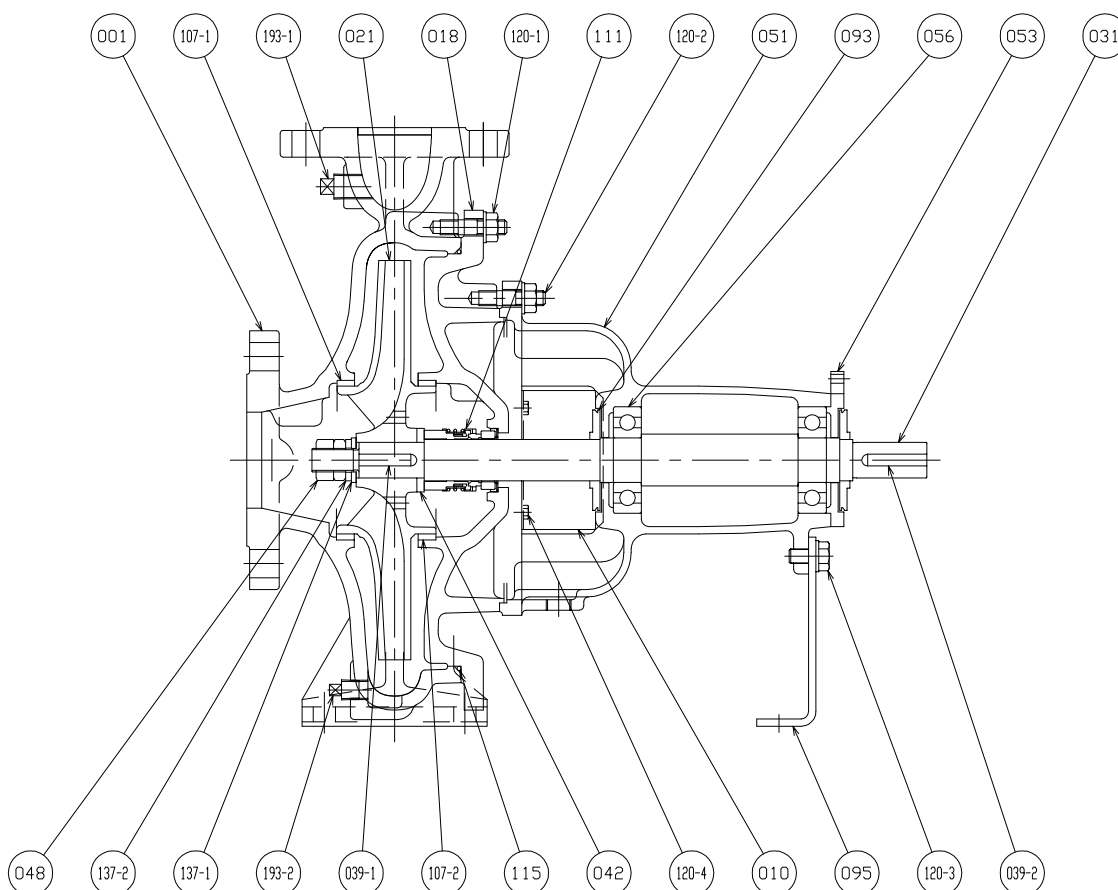

(*1) Duplex stainless steel is used for wetted part only. The remaining atmospheric side of shaft is made of carbon steel.

107-2	CASING RING	SUS316	X5CrNiMo17-12-2(1.4401)	1					
107-1	CASING RING	SUS316	X5CrNiMo17-12-2(1.4401)	1					
095	STAY	SPHC	-	1					
093	DEFLECTOR	-	-	2					
056	BALL BEARING	-	-	2					
053	BEARING COVER	FC150	EN-GJL-150(EN-JL1020)	1					
051	BEARING HOUSING	FC150	EN-GJL-150(EN-JL1020)	1					
048	IMPELLER NUT	SUS304	X5CrNi18-10(1.4301)	1	193-2	PLUG	SUS304	X5CrNi18-10(1.4301)	1
042	SPACER	SUS304	X5CrNi18-10(1.4301)	1	193-1	PLUG	SUS304	X5CrNi18-10(1.4301)	1
039-2	KEY	S50C	C50(1.0540)	1	137-2	SPRING LOCK WASHER	SUS304	X5CrNi18-10(1.4301)	1
039-1	KEY	SUS316	X5CrNiMo17-12-2(1.4401)	1	137-1	PLAIN WASHER	SUS304	X5CrNi18-10(1.4301)	1
031	SHAFT(*1)	SUS329J3L /S35C	X2CrNiMoN22-5-3(1.4462) /C35	1	120-4	BOLT	SS	-	4
021	IMPELLER	SCS13	GX5CrNi19-10(1.4308)	1	120-3	BOLT	SS	-	1
018	CASING COVER	SCS13	GX5CrNi19-10(1.4308)	1	120-2	BOLT	SS	-	6
010	PROTECTOR	SPCC	DC01(1.0330)	2	120-1	BOLT	SS	-	-
001	CASING	SCS13	GX5CrNi19-10(1.4308)	1	115	O-RING	FKM	-	1
					111	MECHANICAL SEAL	-	-	1
No.	NAME OF PART	MATERIAL		Qty	No.	NAME OF PART	MATERIAL		Qty