

Technical Data

Pump Name

JEM 150

Customer	Date	2024-06-16	Company
Contact	Item no.		Issued by
Phone	Project		Phone
E-mail	Project ID	Proiect redenumit 2024-06-16 15:45:44	E-mail

Requested data

1	Pump type	CENTRIFUGAL PUMPS	Fluid	Water
2	Number of pumps / Reserve	1 / 0	Liquid temperature	°C
3	Flow	m³/h	Kin. viscosity	mm²/s
4	Head	m	Vapour pressure	bar
5	Geodetic head	m	PH value	
6	Inlet pressure (pin)	bar	Density	kg/m³
7	Available system NPSH		Solids	Weight %
8	Ambient temperature	°C		

Pump

9	Pump Name	JEM 150	Frequency	Hz	50	
10	Design	CENTRIFUGAL PUMPS	Installation type		STANDARD	
11	Manufacturer	EBARA	Impeller Diameter	Max.	mm	
12	Speed	rpm		2800	Designed	mm
13	No. of Stage			1	Min.	mm
14	Connection	Suction side	UNI ISO 228	Flow	Operating	
15	Connection	Discharge side	UNI ISO 228		Max-	m³/h
16	Max Working Pressure	bar	6		Min-	m³/h
17	Shut-off head	bar	5.78	Head	Operating	
18	Total weight	kg	See the table of "Dimensions".		- (Qmax.)	m
19	Shaft power	kW			- (Qmin.)	m
20				Max. Shaft Power at max. impeller	kW	
21	Required pump NPSH	m		Efficiency	%	

Materials

22	Impeller	AISI 304		
23	Casing	AISI 304		
24	Shaft	AISI 303 (Wet extension)		
25				
26				
27				

Motor

28	Manufacturer	EPE Standard	Insulation class	F	
29	Type	TEFC_JEM 150_230_Single Phase	Phases	1~	
30	Specific design	IE2 / 50 Hz / Pole pairs 1	Frame size		
31	Rated power	kW	1.3	Weight	kg
32	Number of poles		2	Electric voltage	V
33	Speed	rpm	2800	Electric current	A
34	Degree of protection		IP 44		
35					

Remarks

Performance Curve

Pump Name

JEM 150

Customer	Date 2024-06-16	Company
Contact	Item no.	Issued by
Phone	Project	Phone
E-mail	Project ID Proiect redenumit 2024-06-16 15:45:44	E-mail

Requested data

1	Flow	m³/h	
2	Head	m	
3	Geodetic head	m	

Pump

Operating flow	m³/h	Frequency	Hz	50
Operating head	m	Number of poles		2
Impeller diameter designed	mm	141	Speed	rpm 2800

Test standard: ISO 9906:2012 - Grade3B

Water; 20°C; 998.3kg/m³; 1mm²/s

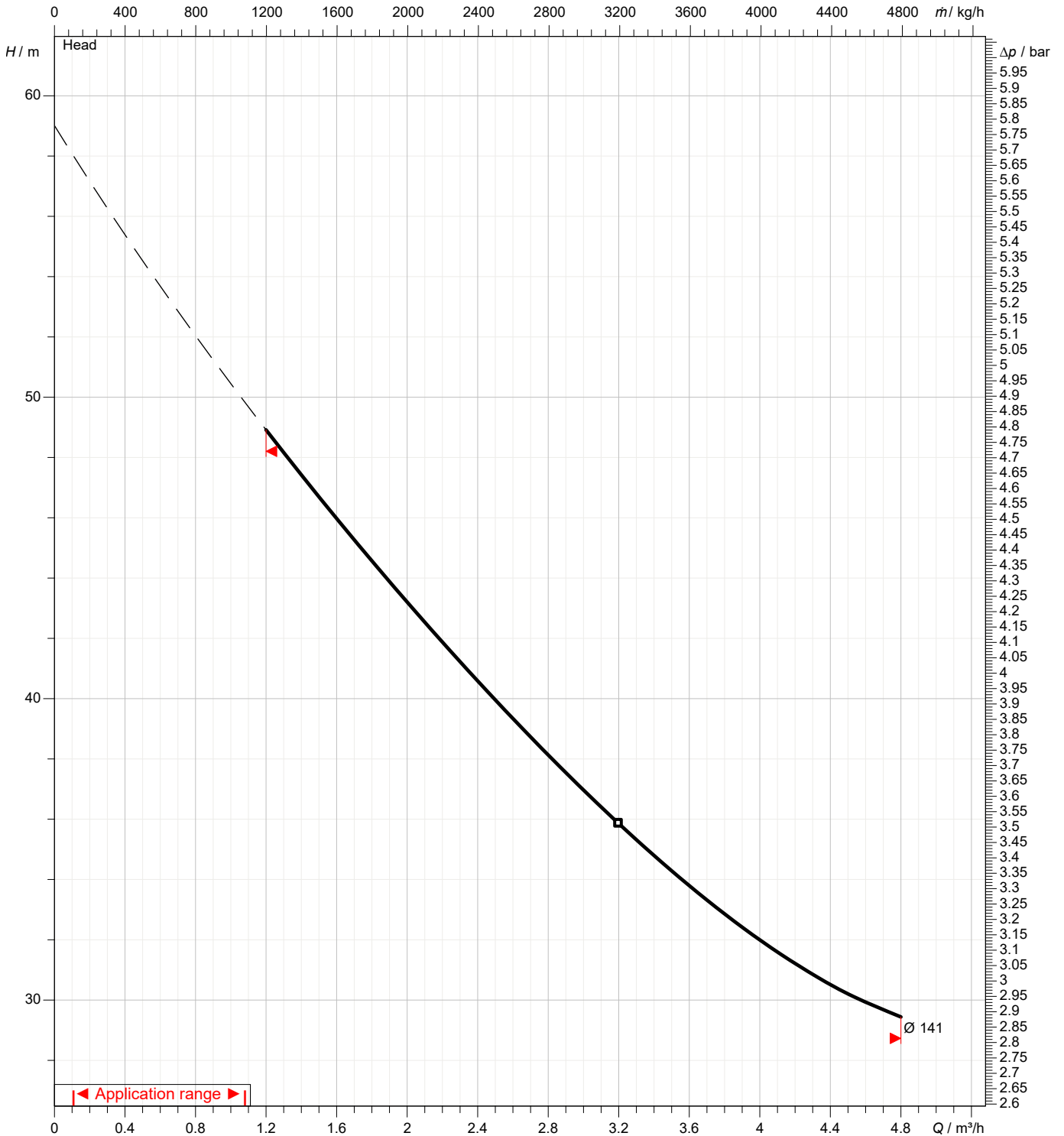

Dimensions

Pump Name JEM 150

Customer	Date 2024-06-16	Company
Contact	Item no.	Issued by
Phone	Project	Phone
E-mail	Project ID Proiect redenumit 2024-06-16 15:45:44	E-mail

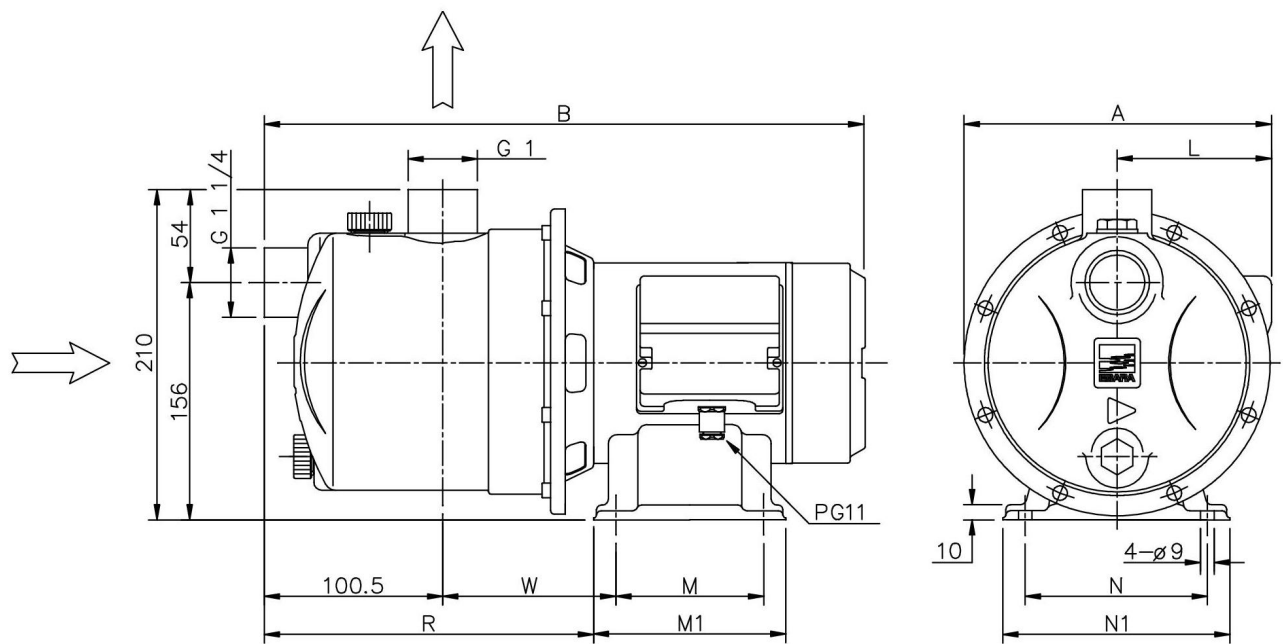

Dimensions in		mm						
1	A	215.5						
2	B	527						
3	L	111.5						
4	M1	150						
5	N	140						
6	N1	170						
7	R	231						
8	W	145.5						
9	Weight P&M	16 kg						
10								
11								
12								
13								
14								
15								

(1/3)

Construction

Pump Name JEM 150

Customer	Date 2024-06-16	Company
Contact	Item no.	Issued by
Phone	Project	Phone
E-mail	Project ID Proiect redenumit 2024-06-16 15:45:44	E-mail

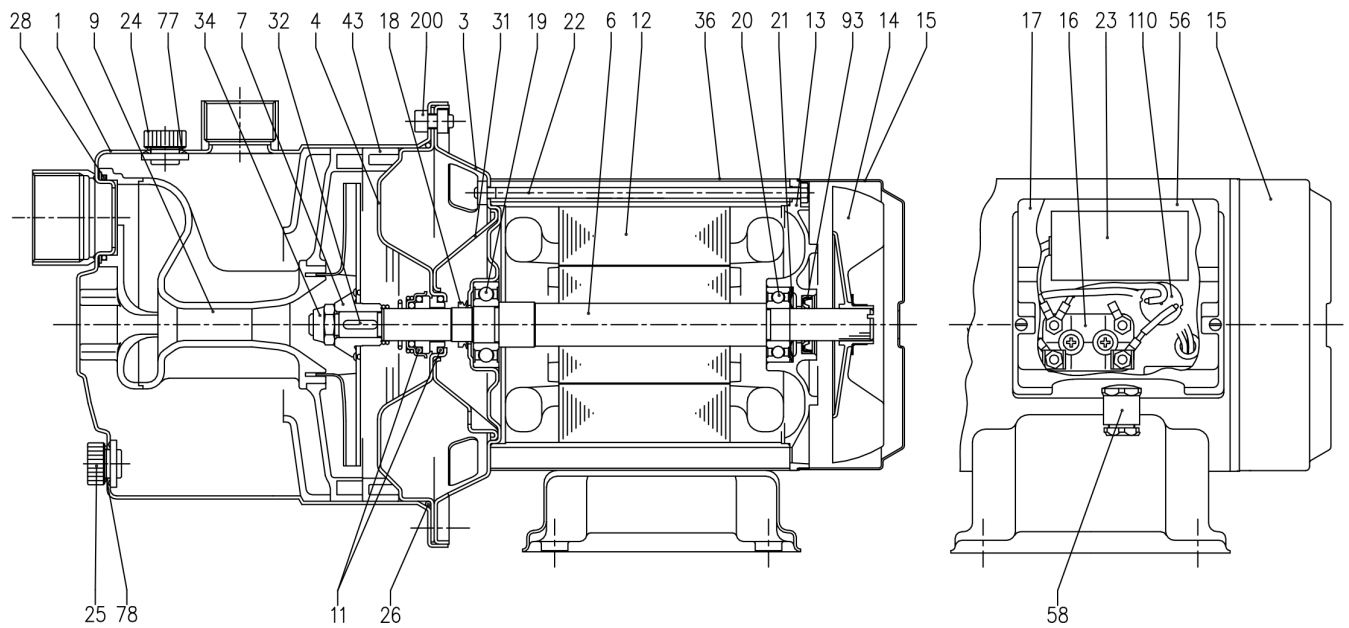

(2/3)

Construction

Pump Name JEM 150

Customer	Date 2024-06-16	Company
Contact	Item no.	Issued by
Phone	Project	Phone
E-mail	Project ID Proiect redenumit 2024-06-16 15:45:44	E-mail

N°	PART NAME	MATERIAL	Q.TY
1	Casing	AISI 304	1
3	Motor bracket	AISI 304	1
4	Casing cover	AISI 304	1
6	Shaft with rotor	AISI 303 (Wet extension)	1
7	Impeller	AISI 304	1
9	Diffuser Venturi tube	PPE+PS glass fibre reinforced	1
11	Mechanical seal [3]	Ceramic/Carbon/NBR	1
12	Motor frame with stator	-	1
13	Motor cover	Aluminium	1
14	Fan	PA	1
15	Fan cover	AISI 304	1
16	Terminal board	-	1
17	Terminal box cover	PA66 glass fibre reinforced class V-0	1
18	Splash ring	NBR	1
19	Pump side ball bearing	-	1
20	Fan side ball bearing	-	1
21	Adjusting ring	Steel C70	1
22	Tie rod	Fe 420 Zincate	4
23	Capacitor [1]	-	1
24	Priming plug	PA	1
25	Drain plug	PA	1
26	O-ring	NBR	1
28	O-ring	NBR	1
31	Thrust flange	AISI 304	1
32	Key	AISI 304	1
34	Impeller nut	AISI 304	1
36	External motor casing	AISI 304	1
43	Space diffuser	PPE+PS glass fibre reinforced	1
56	Box gasket	NBR	1
58	Cable entry	-	1
77	O-ring	NBR	1
78	O-ring	NBR	1
93	Lip seal [2]	NBR	1
110	Protector [1]	-	1
200	Screw	Stainless steel A2 UNI7323	8

[1] Only for single phase

[2] Only for IP55

[3] See **CONSTRUCTION 3**

(3/3)

Construction

Pump Name JEM 150

Customer	Date 2024-06-16	Company
Contact	Item no.	Issued by
Phone	Project	Phone
E-mail	Project ID Proiect redenumit 2024-06-16 15:45:44	E-mail

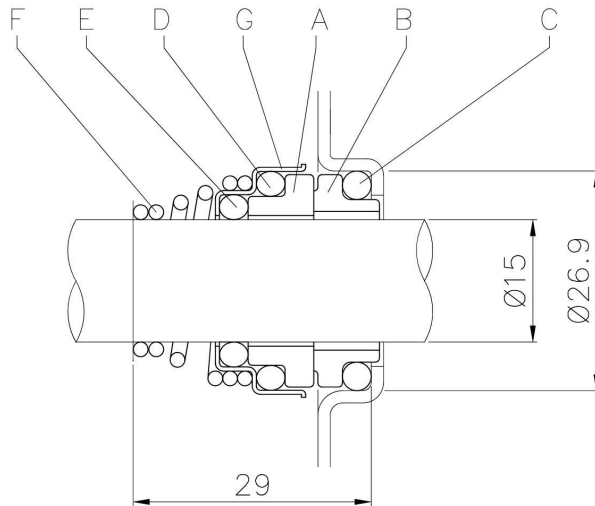

REF	PART NAME	MATERIAL
A	Rotary seal ring	Ceramic
B	Stationary seal ring	Carbon graphite
C	O R ing	NBR
D	O R ing	NBR
E	O R ing	NBR
F	Selfdriving spring	A IS 1316
G	Fram e	A IS 1304