

Technical Data

Pump Name

JESM 5

Customer	Date	2024-06-16	Company
Contact	Item no.		Issued by
Phone	Project		Phone
E-mail	Project ID	Proiect redenumit 2024-06-16 15:45:44	E-mail

Requested data

1	Pump type	CENTRIFUGAL PUMPS	Fluid	Water
2	Number of pumps / Reserve	1 / 0	Liquid temperature	°C
3	Flow	m³/h	Kin. viscosity	mm²/s
4	Head	m	Vapour pressure	bar
5	Geodetic head	m	PH value	
6	Inlet pressure (pin)	bar	Density	kg/m³
7	Available system NPSH		Solids	Weight %
8	Ambient temperature	°C		

Pump

9	Pump Name	JESM 5	Frequency	Hz	50	
10	Design	CENTRIFUGAL PUMPS	Installation type		STANDARD	
11	Manufacturer	EBARA	Impeller Diameter	Max.	mm	
12	Speed	rpm		3000	Designed	mm
13	No. of Stage	1		Min.	mm	104
14	Connection	Suction side	UNI ISO 228	Flow	Operating	m³/h
15	Connection	Discharge side	UNI ISO 228		Max-	m³/h
16	Max Working Pressure	bar	6		Min-	m³/h
17	Shut-off head	bar	3.13	Head	Operating	m
18	Total weight	kg	See the table of "Dimensions".		- (Qmax.)	m
19	Shaft power	kW			- (Qmin.)	m
20				Max. Shaft Power at max. impeller	kW	
21	Required pump NPSH	m		Efficiency	%	

Materials

22	Impeller	PPO mod. glass fibre reinforced	
23	Casing	AISI 304	
24	Shaft	AISI 303 (Wet extension)	
25			
26			
27			

Motor

28	Manufacturer	EPE Standard	Insulation class	F	
29	Type	TEFC_JES 5_230_Three Phase	Phases	3~	
30	Specific design	- / 50 Hz / Pole pairs 1	Frame size		
31	Rated power	kW	0.37	Weight	kg
32	Number of poles	2	Electric voltage	V	230
33	Speed	rpm	3000	Electric current	A
34	Degree of protection	IP 44			
35					

Remarks

Performance Curve

Pump Name

JESM 5

Customer	Date	2024-06-16	Company
Contact	Item no.		Issued by
Phone	Project		Phone
E-mail	Project ID	Project redenumit 2024-06-16 15:45:44	E-mail

Requested data

1	Flow	m³/h	
2	Head	m	
3	Geodetic head	m	

Pump

Operating flow	m³/h		Frequency	Hz	50
Operating head	m		Number of poles		2
Impeller diameter designed	mm	104	Speed	rpm	3000

Test standard: ISO 9906:2012 - Grade3B

Water; 20°C; 998.3kg/m³; 1mm²/s

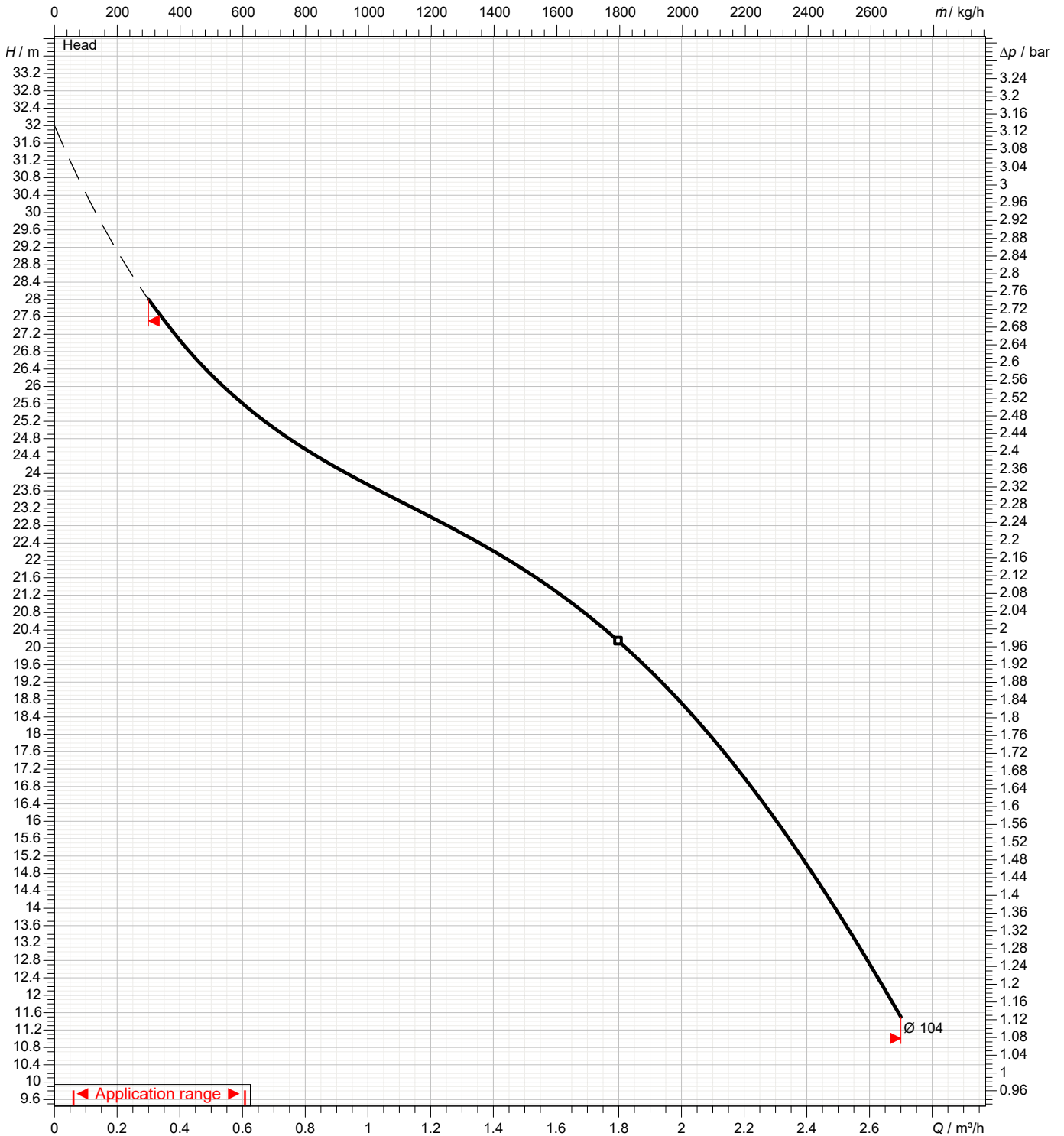

Dimensions

Pump Name JESM 5

Customer	Date 2024-06-16	Company
Contact	Item no.	Issued by
Phone	Project	Phone
E-mail	Project ID Proiect redenumit 2024-06-16 15:45:44	E-mail

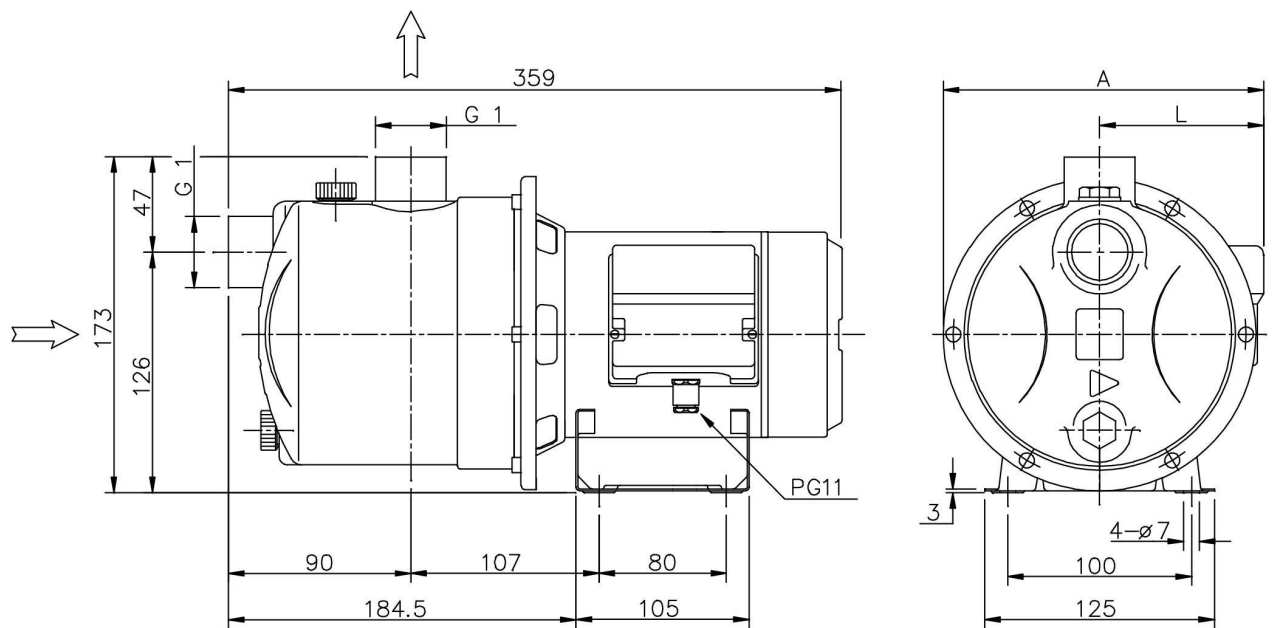

Dimensions in		mm						
1	A	181						
2	L	96						
3	Weight P&M	5.6 kg						
4								
5								
6								
7								
8								
9								
10								
11								
12								
13								
14								
15								

(1/3) Construction

Pump Name JESM 5

Customer	Date 2024-06-16	Company
Contact	Item no.	Issued by
Phone	Project	Phone
E-mail	Project ID Proiect redenumit 2024-06-16 15:45:44	E-mail

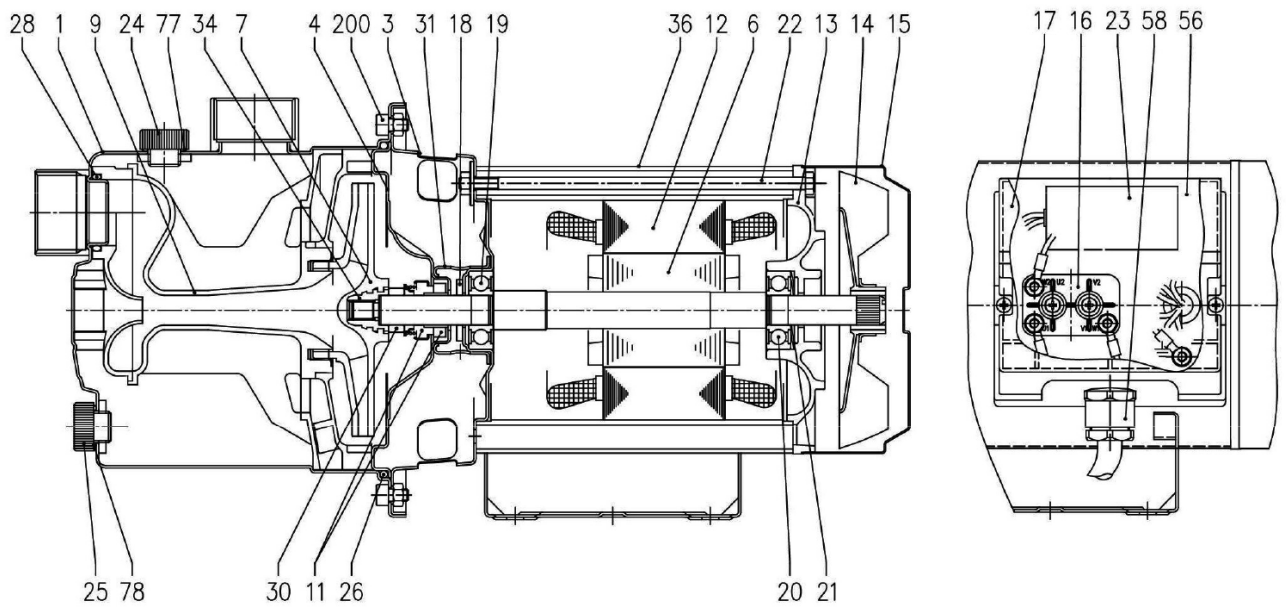

(2/3)

Construction

Pump Name JESM 5

Customer	Date 2024-06-16	Company
Contact	Item no.	Issued by
Phone	Project	Phone
E-mail	Project ID Proiect redenumit 2024-06-16 15:45:44	E-mail

N°	PART NAME	MATERIAL	Q.TY
1	Casing	AISI 304	1
3	Motor bracket	AISI 304	1
4	Casing cover	AISI 304	1
6	Shaft with rotor	AISI 303 (Wet extension)	1
7	Impeller	PPO mod. glass fibre reinforced	1
9	Diffuser Venturi tube	PPO mod. glass fibre reinforced	1
11	Mechanical seal [3]	Carbon/Ceramic/NBR	1
12	Motor frame with stator	-	1
13	Motor cover	Aluminium	1
14	Fan	PA6	1
15	Fan cover	Fe P04 Zincate	1
16	Terminal board	-	1
17	Terminal box cover	PA66 glass fibre reinforced	1
18	Splash ring	NBR	1
19	Pump side ball bearing	6201 ZZ	1
20	Fan side ball bearing	6201 ZZ	1
21	Adjusting ring	Steel C70	1
22	Tie rod	Fe 42 Zincate	4
23	Capacitor [1]	-	1
24	Priming plug	PA6	1
25	Drain plug	PA6	1
26	O-ring	NBR	1
28	O-ring	NBR	1
30	Mechanical seal spacer	Brass	1
31	Thrust flange	AISI 304	1
34	Impeller nut [2]	AISI 304	1
36	External motor casing	AISI 304	1
56	Box gasket	NBR	1
58	Cable entry	-	1
77	O-ring	NBR	1
78	O-ring	NBR	1
200	Screw	Stainless steel A2 UNI7323	6

[1] Only for single phase

[2] Only for three phase

[3] See **CONSTRUCTION 3**

(3/3)

Construction

Pump Name JESM 5

Customer	Date 2024-06-16	Company
Contact	Item no.	Issued by
Phone	Project	Phone
E-mail	Project ID Proiect redenumit 2024-06-16 15:45:44	E-mail

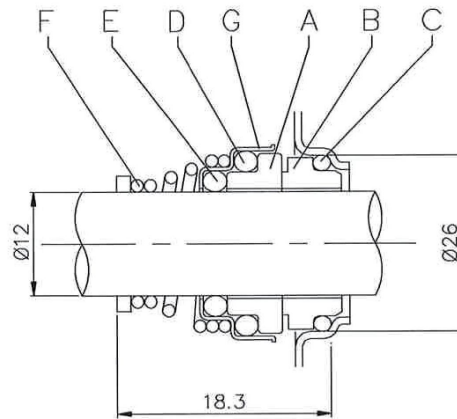

REF	PART NAME	MATERIAL
A	Rotary seal ring	ceramic
B	Stationary seal ring	carbon graphite
C	O Ring	NBR
D	O Ring	NBR
E	O Ring	NBR
F	Self driving spring	AISI 316
G	Frame	AISI 304