

Technical Data

Pump Name

LPC4 40-250/1.1 QQPFF

| | | | |
|----------|------------|---------------------------------------|-----------|
| Customer | Date | 2024-06-16 | Company |
| Contact | Item no. | | Issued by |
| Phone | Project | | Phone |
| E-mail | Project ID | Proiect redenumit 2024-06-16 15:45:44 | E-mail |

Requested data

| | | | | |
|---|---------------------------|-------------------|--------------------|----------|
| 1 | Pump type | CENTRIFUGAL PUMPS | Fluid | Water |
| 2 | Number of pumps / Reserve | 1 / 0 | Liquid temperature | °C |
| 3 | Flow | m³/h | Kin. viscosity | mm²/s |
| 4 | Head | m | Vapour pressure | bar |
| 5 | Geodetic head | m | PH value | |
| 6 | Inlet pressure (pin) | bar | Density | kg/m³ |
| 7 | Available system NPSH | | Solids | Weight % |
| 8 | Ambient temperature | °C | | |

Pump

| | | | | | | |
|----|----------------------|-----------------------|--------------------------------|-----------------------------------|-----------|------|
| 9 | Pump Name | LPC4 40-250/1.1 QQPFF | Frequency | Hz | 50 | |
| 10 | Design | CENTRIFUGAL PUMPS | Installation type | | STANDARD | |
| 11 | Manufacturer | EBARA | Impeller Diameter | Max. | mm | |
| 12 | Speed | rpm | | 1450 | Designed | mm |
| 13 | No. of Stage | | | 1 | Min. | mm |
| 14 | Connection | Suction side | Flow | Operating | m³/h | |
| 15 | Connection | Discharge side | | Max- | m³/h | 15 |
| 16 | Max Working Pressure | bar | | 10 | Min- | m³/h |
| 17 | Shut-off head | bar | 1.86 | Head | Operating | m |
| 18 | Total weight | kg | See the table of "Dimensions". | | - (Qmax.) | m |
| 19 | Shaft power | kW | | | - (Qmin.) | m |
| 20 | | | | Max. Shaft Power at max. impeller | kW | 1.09 |
| 21 | Required pump NPSH | m | | Efficiency | % | |

Materials

| | | | | |
|----|---------------------|-----------------|--|--|
| 22 | Impeller | EN-GJL-200 | | |
| 23 | Intermediate casing | EN-GJL-200 | | |
| 24 | Bottom casing | EN-GJL-200 | | |
| 25 | Shaft | Stainless steel | | |
| 26 | Gasket | AF1600 | | |
| 27 | | | | |

Motor

| | | | | | |
|----|----------------------|--------------------------------------|------------------|------------------|----|
| 28 | Manufacturer | ICME | Insulation class | F | |
| 29 | Type | TEFC_LPC4 40-250/1.1_230_Three Phase | Phases | 3~ | |
| 30 | Specific design | IE3 / 50 Hz / Pole pairs 2 | Frame size | 90 | |
| 31 | Rated power | kW | 1.1 | Weight | kg |
| 32 | Number of poles | | 4 | Electric voltage | V |
| 33 | Speed | rpm | 1420 | Electric current | A |
| 34 | Degree of protection | | IP 55 | | |
| 35 | | | | | |

Remarks

Performance Curve

Pump Name

LPC4 40-250/1.1 QQPFF

| | | | |
|----------|------------|---------------------------------------|-----------|
| Customer | Date | 2024-06-16 | Company |
| Contact | Item no. | | Issued by |
| Phone | Project | | Phone |
| E-mail | Project ID | Project redenumit 2024-06-16 15:45:44 | E-mail |

Requested data

| | | | |
|---|---------------|------|--|
| 1 | Flow | m³/h | |
| 2 | Head | m | |
| 3 | Geodetic head | m | |

Pump

| | | | | | |
|----------------------------|------|-----|-----------------|-----|------|
| Operating flow | m³/h | | Frequency | Hz | 50 |
| Operating head | m | | Number of poles | | 4 |
| Impeller diameter designed | mm | 240 | Speed | rpm | 1450 |

Test standard: ISO 9906:2012 - Grade3B

Water; 20°C; 998.3kg/m³; 1mm²/s

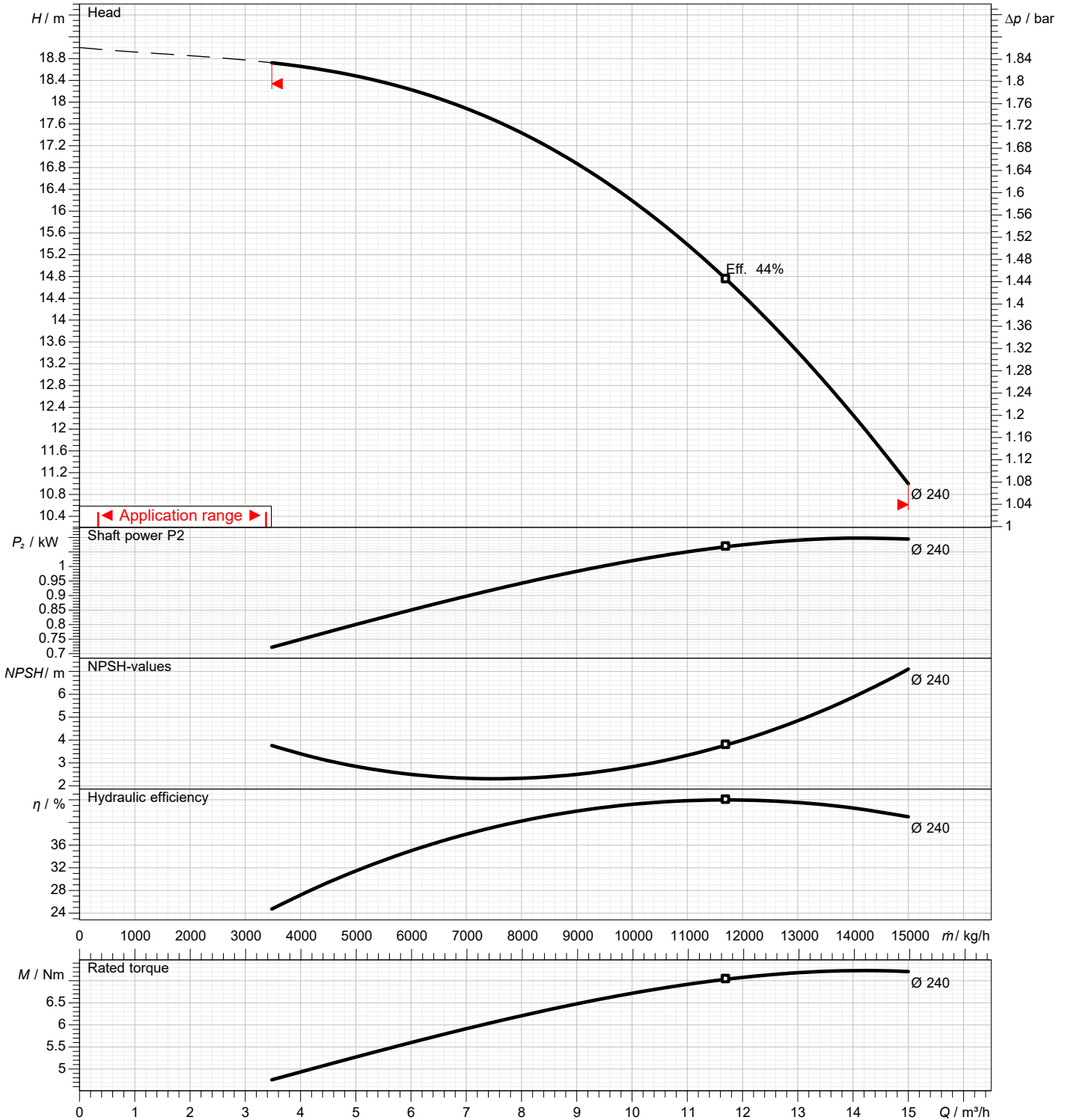

Dimensions

Pump name **LPC4 40-250/1.1 QQPFF**

| | | |
|----------|--|-----------|
| Customer | Date 2024-06-16 | Company |
| Contact | Item no. | Issued by |
| Phone | Project | Phone |
| E-mail | Project ID Proiect redenumit 2024-06-16 15:45:44 | E-mail |

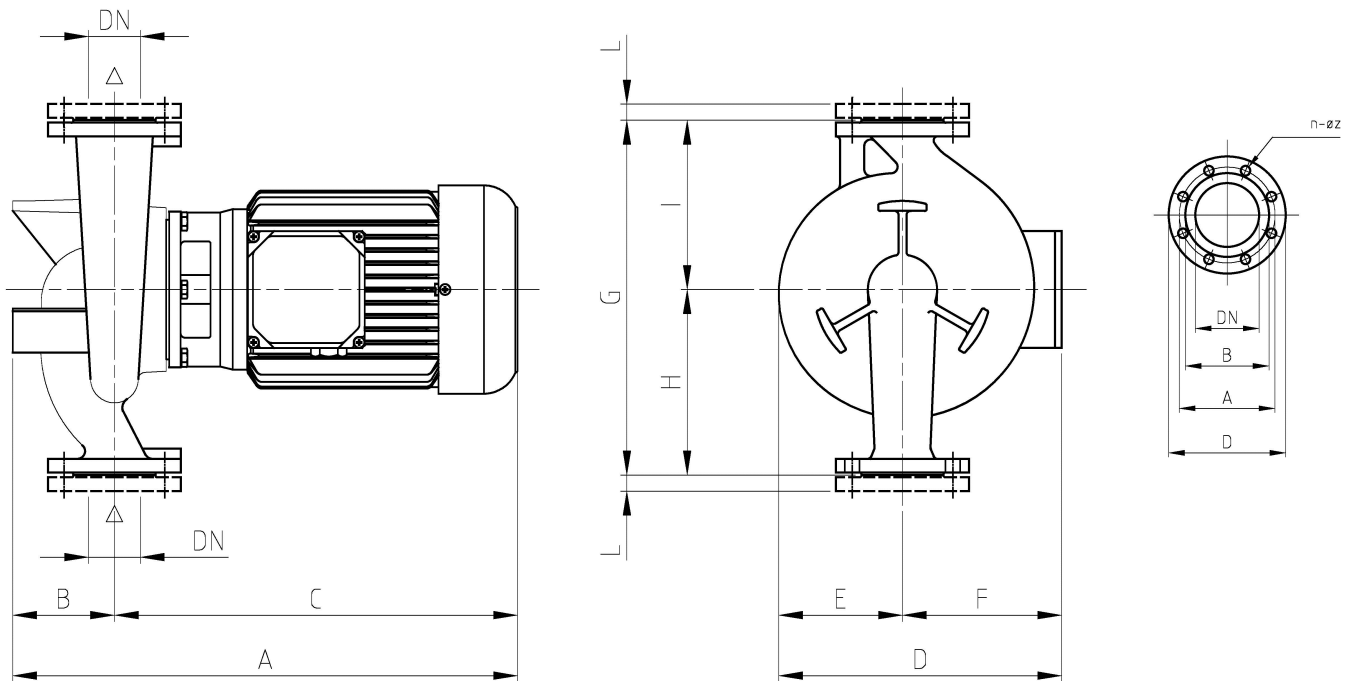

| Dimensions in | | mm | | | | | | |
|---------------|--------|-----|-----------------|---------------|--|--|--|--|
| 1 | A | 481 | L Weight P&M | 20 54,6 kg | | | | |
| 2 | B | 100 | | | | | | |
| 3 | C | 381 | | | | | | |
| 4 | D | 313 | | | | | | |
| 5 | Dia A | 100 | | | | | | |
| 6 | Dia B | 80 | | | | | | |
| 7 | Dia D | 130 | | | | | | |
| 8 | Dia DN | 40 | | | | | | |
| 9 | Dia n | 4 | | | | | | |
| 10 | Dia Z | 14 | | | | | | |
| 11 | E | 165 | | | | | | |
| 12 | F | 148 | | | | | | |
| 13 | G | 440 | | | | | | |
| 14 | H | 230 | | | | | | |
| 15 | I | 210 | | | | | | |

(1/2) Construction

Pump name **LPC4 40-250/1.1 QQPFF**

| | | |
|----------|--|-----------|
| Customer | Date 2024-06-16 | Company |
| Contact | Item no. | Issued by |
| Phone | Project | Phone |
| E-mail | Project ID Proiect redenumit 2024-06-16 15:45:44 | E-mail |

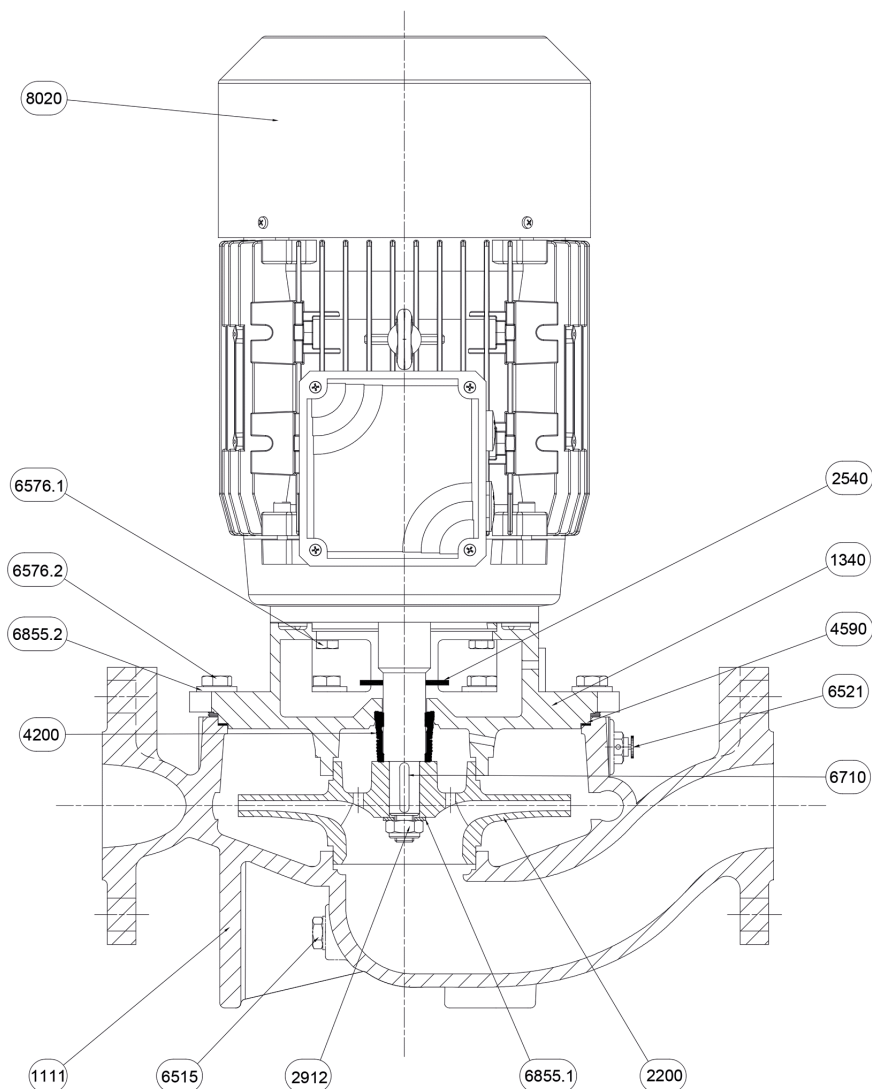

| N° | PART NAME | MATERIAL | Q.TY |
|--------|----------------------|----------------------|------|
| 1111 | Pump casing | EN-GJL-200 | 1 |
| 1340 | Latern-Cover | EN-GJL-200 | 1 |
| 2200 | Impeller | EN-GJL-200 | 1 |
| 2540 | Baffle | NB 70 | 1 |
| 2912 | Impeller nut | 6.8-ZN | 1 |
| 4200 | Mechanical seal | Sic/Sic/NBR/AISI 304 | 1 |
| 4590 | Gasket | AF 1600 | 1 |
| 6515 | Drain plug | EN-GJMB-350-10 | 1 |
| 6521 | Vent valve | CW509L | 1 |
| 6576.1 | Hexagonal head screw | 8.8-ZN | 4 |
| 6576.2 | Hexagonal head screw | 8.8-ZN | 12 |
| 6710 | Key | C50 | 1 |
| 6855.1 | Impeller washer | R40-ZN | 1 |
| 6855.2 | Washer | R40-ZN | 12 |
| 8020 | Motor | | 1 |

(2/2)

Construction

Pump name LPC4 40-250/1.1 QQPFF

| | | |
|----------|--|-----------|
| Customer | Date 2024-06-16 | Company |
| Contact | Item no. | Issued by |
| Phone | Project | Phone |
| E-mail | Project ID Proiect redenumit 2024-06-16 15:45:44 | E-mail |



| Ref. | Name | Material |
|------|----------------------|-----------------|
| A | Rotary seal ring | Carbon |
| B | Stationary seal ring | Silicon Carbide |
| C | Gasket | EPDM |
| D | Bellows | EPDM |
| E | Spring plate | AISI 304 |
| F | Spring | AISI 304 |
| G | Spring plate | AISI 304 |