

Technical Data

Pump Name

LPC4 65-200/1.1 QQPFF

Customer	Date	2024-06-16	Company
Contact	Item no.		Issued by
Phone	Project		Phone
E-mail	Project ID	Proiect redenumit 2024-06-16 15:45:44	E-mail

Requested data

1	Pump type	CENTRIFUGAL PUMPS	Fluid	Water	
2	Number of pumps / Reserve	1 / 0	Liquid temperature	°C	20
3	Flow	m³/h	Kin. viscosity	mm²/s	1.005
4	Head	m	Vapour pressure	bar	0.0234
5	Geodetic head	m	PH value		
6	Inlet pressure (pin)	bar	Density	kg/m³	998.3
7	Available system NPSH		Solids	Weight %	0
8	Ambient temperature	°C	20		

Pump

9	Pump Name	LPC4 65-200/1.1 QQPFF	Frequency	Hz	50		
10	Design	CENTRIFUGAL PUMPS	Installation type		STANDARD		
11	Manufacturer	EBARA	Impeller Diameter	Max.	mm	200	
12	Speed	rpm		1450	Designed	mm	200
13	No. of Stage	1		Min.	mm	200	
14	Connection	Suction side	Flow	Operating	m³/h		
15	Connection	Discharge side		Max-	m³/h	36	
16	Max Working Pressure	bar		10	Min-	m³/h	6.36
17	Shut-off head	bar	1.23	Head	Operating	m	
18	Total weight	kg	See the table of "Dimensions".		- (Qmax.)	m	5.8
19	Shaft power	kW			- (Qmin.)	m	12.6
20			Max. Shaft Power at max. impeller	kW	1.10		
21	Required pump NPSH	m	Efficiency	%			

Materials

22	Impeller	EN-GJL-200		
23	Intermediate casing	EN-GJL-200		
24	Bottom casing	EN-GJL-200		
25	Shaft	Stainless steel		
26	Gasket	AF1600		
27				

Motor

28	Manufacturer	ICME	Insulation class	F		
29	Type	TEFC_LPC4 65-200/1.1_230_Three Phase	Phases	3~		
30	Specific design	IE3 / 50 Hz / Pole pairs 2	Frame size	90		
31	Rated power	kW	1.1	Weight	kg	14
32	Number of poles	4	Electric voltage	V	230	
33	Speed	rpm	1420	Electric current	A	4.2
34	Degree of protection	IP 55				
35						

Remarks

--

Performance Curve

Pump Name

LPC4 65-200/1.1 QQPFF

Customer	Date	2024-06-16	Company
Contact	Item no.		Issued by
Phone	Project		Phone
E-mail	Project ID	Proiect redenumit 2024-06-16 15:45:44	E-mail

Requested data

1	Flow	m³/h	
2	Head	m	
3	Geodetic head	m	

Pump

Operating flow	m³/h		Frequency	Hz	50
Operating head	m		Number of poles		4
Impeller diameter designed	mm	200	Speed	rpm	1450

Test standard: ISO 9906:2012 - Grade3B

Water; 20°C; 998.3kg/m³; 1mm²/s

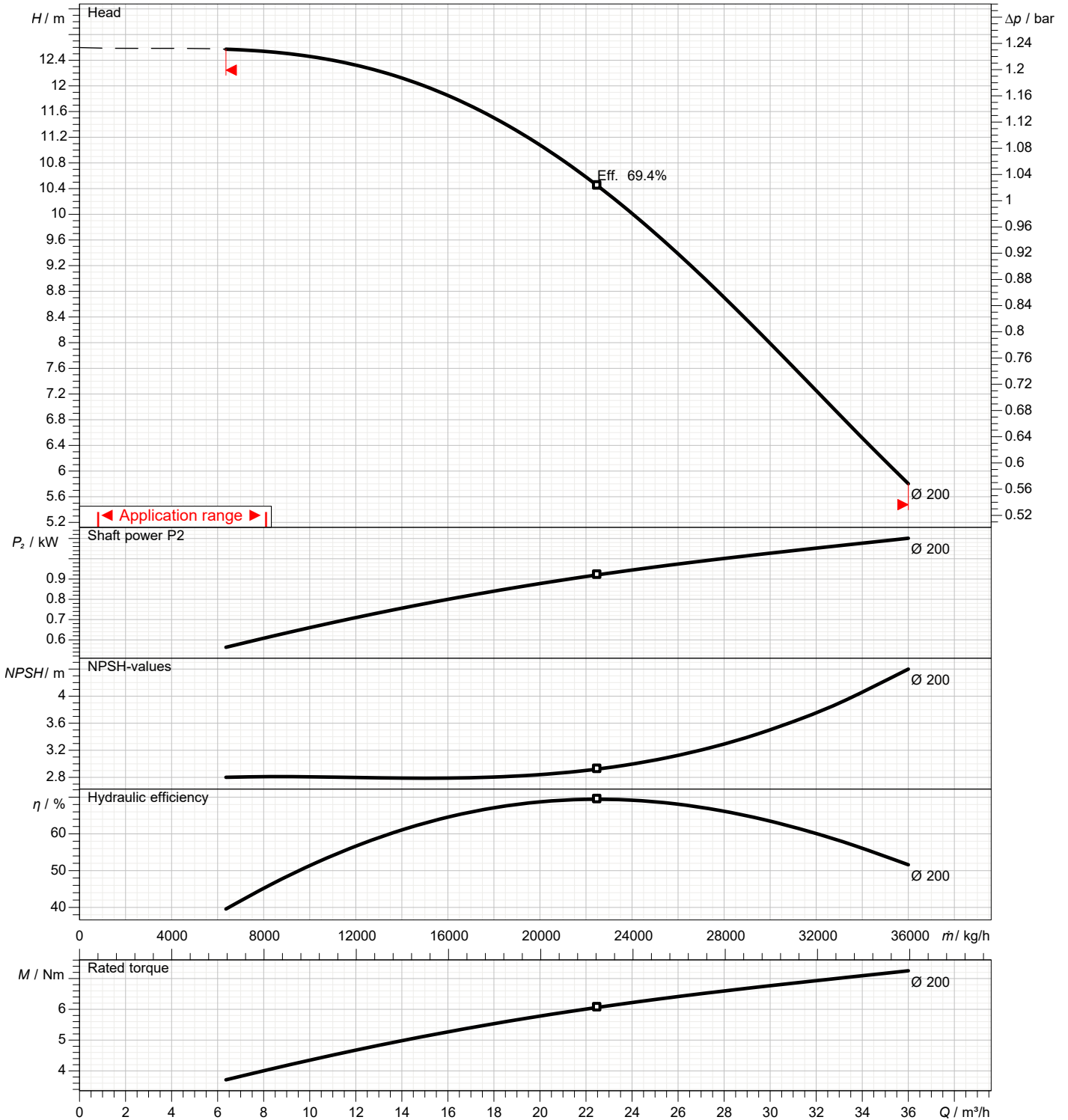

Dimensions

Pump name **LPC4 65-200/1.1 QQPFF**

Customer	Date 2024-06-16	Company
Contact	Item no.	Issued by
Phone	Project	Phone
E-mail	Project ID Proiect redenumit 2024-06-16 15:45:44	E-mail

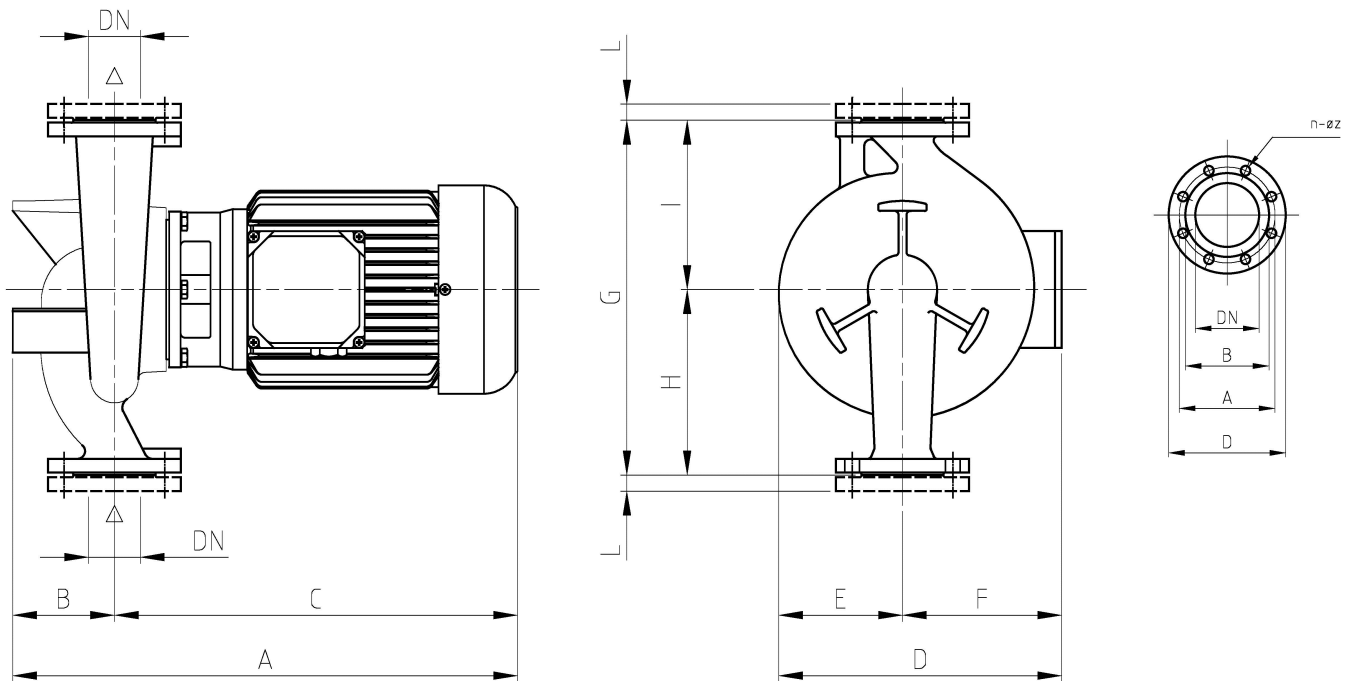

Dimensions in		mm							
1	A	521	L Weight P&M	22 41,6 kg					
2	B	140							
3	C	381							
4	D	284							
5	Dia A	145							
6	Dia B	122							
7	Dia D	185							
8	Dia DN	65							
9	Dia n	4							
10	Dia Z	18							
11	E	136							
12	F	148							
13	G	440							
14	H	240							
15	I	200							

(1/2) Construction

Pump name **LPC4 65-200/1.1 QQPFF**

Customer	Date 2024-06-16	Company
Contact	Item no.	Issued by
Phone	Project	Phone
E-mail	Project ID Proiect redenumit 2024-06-16 15:45:44	E-mail

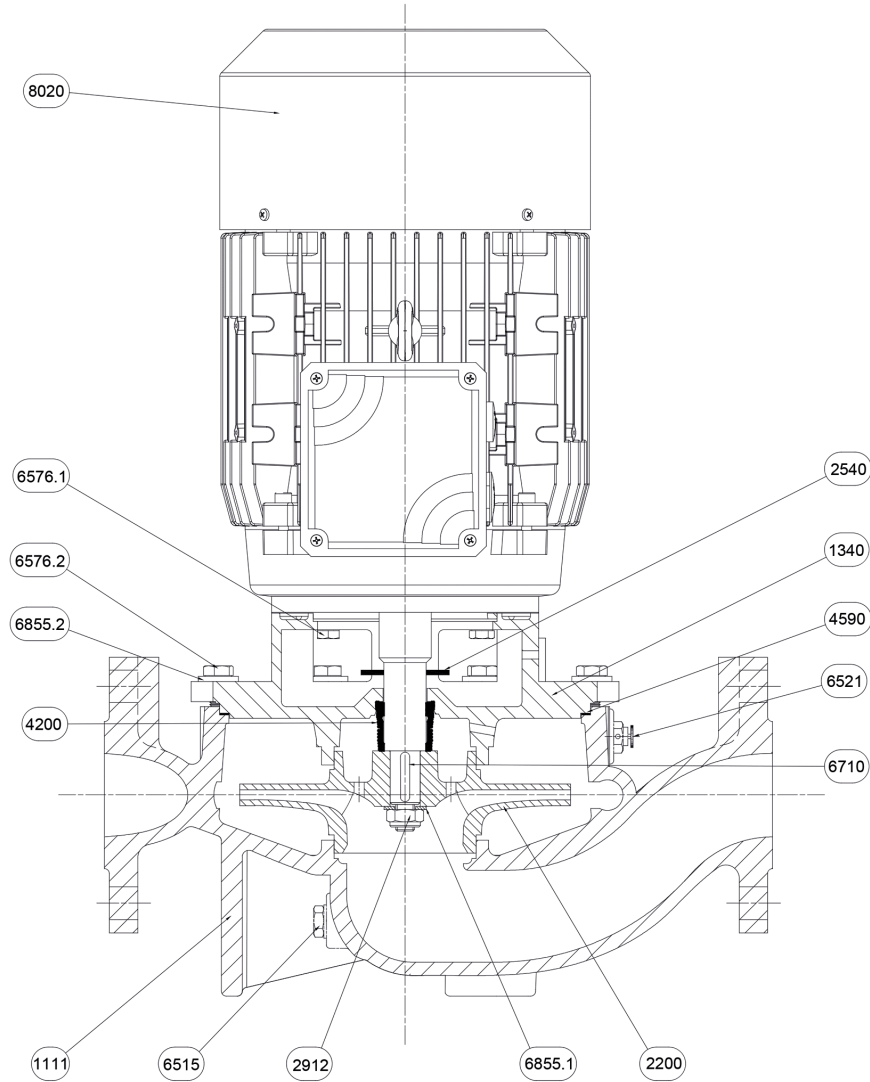

N°	PART NAME	MATERIAL	Q.TY
1111	Pump casing	EN-GJL-200	1
1340	Latern-Cover	EN-GJL-200	1
2200	Impeller	EN-GJL-200	1
2540	Baffle	NB 70	1
2912	Impeller nut	6.8-ZN	1
4200	Mechanical seal	Sic/Sic/NBR/AISI 304	1
4590	Gasket	AF 1600	1
6515	Drain plug	EN-GJMB-350-10	1
6521	Vent valve	CW509L	1
6576.1	Hexagonal head screw	8.8-ZN	4
6576.2	Hexagonal head screw	8.8-ZN	8
6710	Key	C50	1
6855.1	Impeller washer	R40-ZN	1
6855.2	Washer	R40-ZN	8
8020	Motor		1

(2/2)

Construction

Pump name LPC4 65-200/1.1 QQPFF

Customer	Date 2024-06-16	Company
Contact	Item no.	Issued by
Phone	Project	Phone
E-mail	Project ID Proiect redenumit 2024-06-16 15:45:44	E-mail



Ref.	Name	Material
A	Rotary seal ring	Carbon
B	Stationary seal ring	Silicon Carbide
C	Gasket	EPDM
D	Bellows	EPDM
E	Spring plate	AISI 304
F	Spring	AISI 304
G	Spring plate	AISI 304