

Technical Data

Pump Name

LPCD4 65-160/0.75R QQPFF

Customer	Date	2024-06-16	Company
Contact	Item no.		Issued by
Phone	Project		Phone
E-mail	Project ID	Proiect redenumit 2024-06-16 15:45:44	E-mail

Requested data

1	Pump type	CENTRIFUGAL PUMPS	Fluid	Water
2	Number of pumps / Reserve	1 / 0	Liquid temperature	°C 20
3	Flow m³/h		Kin. viscosity	mm²/s 1.005
4	Head m		Vapour pressure	bar 0.0234
5	Geodetic head m		PH value	
6	Inlet pressure (pin) bar	0	Density	kg/m³ 998.3
7	Available system NPSH		Solids	Weight % 0
8	Ambient temperature °C	20		

Pump

9	Pump Name	LPCD4 65-160/0.75R QQPFF	Frequency	Hz	50
10	Design	CENTRIFUGAL PUMPS	Installation type		STANDARD
11	Manufacturer	EBARA	Impeller Diameter	Max. mm	150
12	Speed rpm	1450		Designed mm	150
13	No. of Stage	1		Min. mm	150
14	Connection Suction side		Flow	Operating m³/h	
15	Connection Discharge side			Max- m³/h	30
16	Max Working Pressure bar	10		Min- m³/h	6
17	Shut-off head bar	0.68	Head	Operating m	
18	Total weight kg	See the table of "Dimensions".		- (Qmax.) m	3.3
19	Shaft power kW			- (Qmin.) m	6.8
20			Max. Shaft Power at max. impeller	kW	0.49
21	Required pump NPSH m		Efficiency	%	

Materials

22	Impeller	EN-GJL-200		
23	Intermediate casing	EN-GJL-200		
24	Bottom casing	EN-GJL-200		
25	Shaft	Stainless steel		
26	Gasket	AF1600		
27				

Motor

28	Manufacturer	ICME	Insulation class	F
29	Type	TEFC_LPCD4 65-160/0.75R_230_Three Phase	Phases	3~
30	Specific design	IE3 / 50 Hz / Pole pairs 2	Frame size	80
31	Rated power kW	0.75	Weight kg	10
32	Number of poles	4	Electric voltage V	230
33	Speed rpm	1440	Electric current A	3
34	Degree of protection	IP 55		
35				

Remarks

Performance Curve

Pump Name

LPCD4 65-160/0.75R QQPFF

Customer	Date	2024-06-16	Company
Contact	Item no.		Issued by
Phone	Project		Phone
E-mail	Project ID	Project redenumit 2024-06-16 15:45:44	E-mail

Requested data

1	Flow	m³/h	
2	Head	m	
3	Geodetic head	m	

Pump

Operating flow	m³/h		Frequency	Hz	50
Operating head	m		Number of poles		4
Impeller diameter designed	mm	150	Speed	rpm	1450

Test standard: ISO 9906:2012 - Grade3B

Water; 20°C; 998.3kg/m³; 1mm²/s

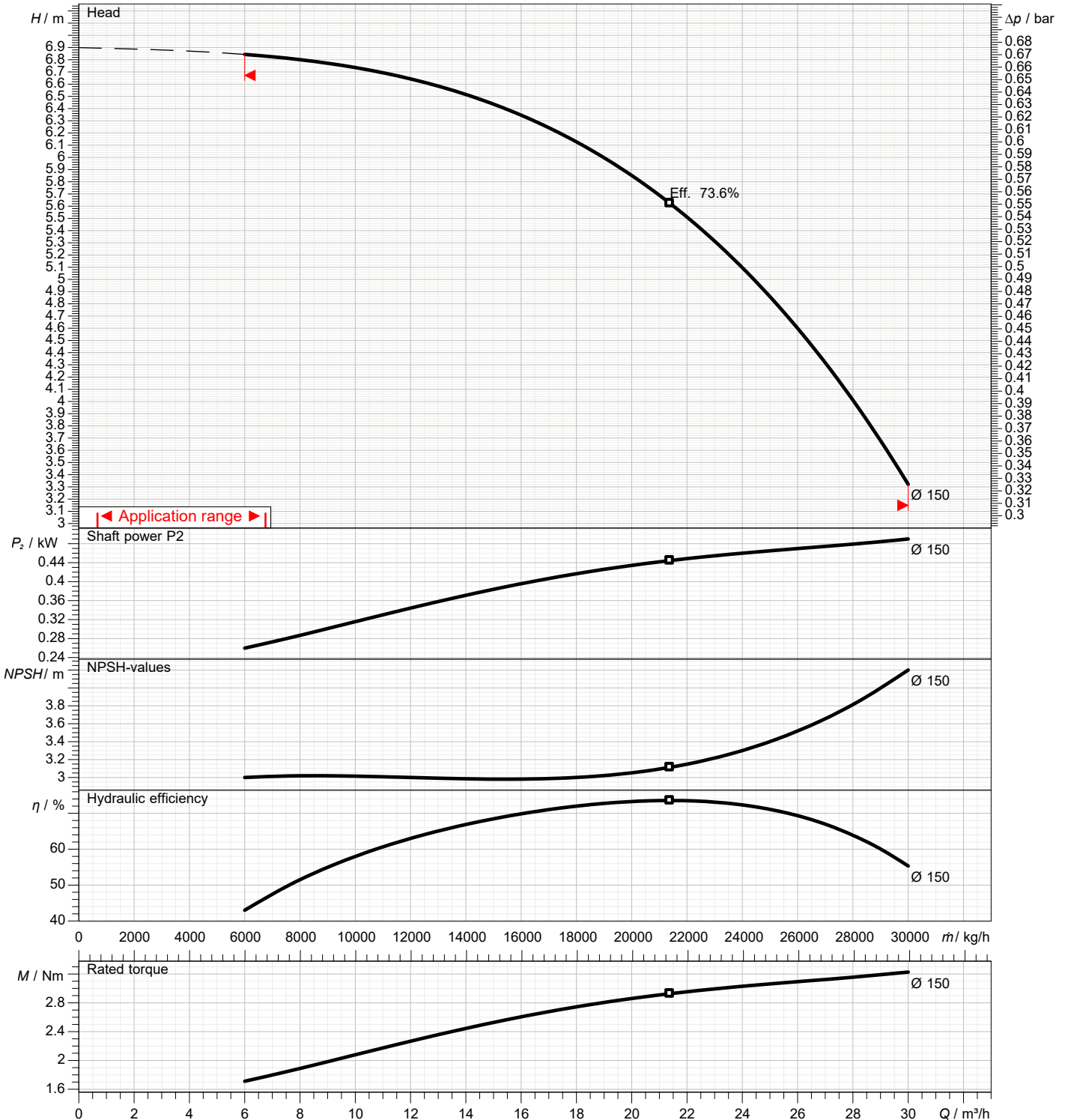

Dimensions

Pump name **LPCD4 65-160/0.75R QQPFF**

Customer	Date 2024-06-16	Company
Contact	Item no.	Issued by
Phone	Project	Phone
E-mail	Project ID Proiect redenumit 2024-06-16 15:45:44	E-mail

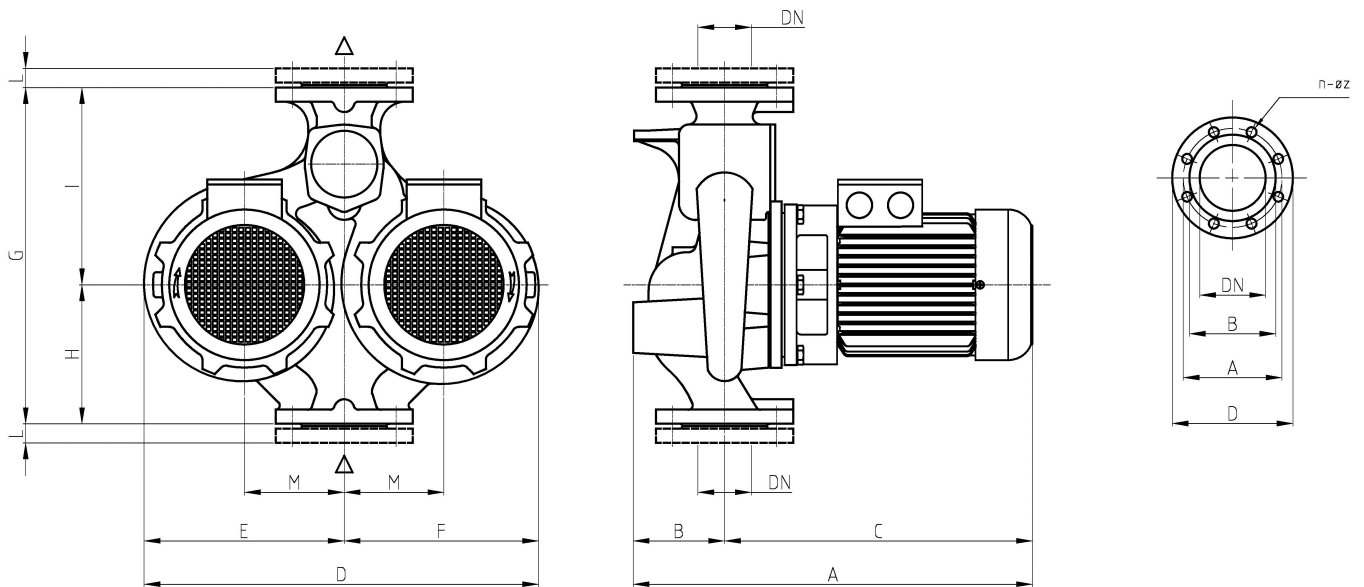

Dimensions in		mm						
1	A	460	L	22				
2	B	130	M	140				
3	C	330	Weight P&M	[66].2 kg				
4	D	543						
5	Dia A	145						
6	Dia B	122						
7	Dia D	185						
8	Dia DN	65						
9	Dia n	4						
10	Dia Z	18						
11	E	275						
12	F	268						
13	G	450						
14	H	180						
15	I	270						

(1/2)

Construction

Pump name LPCD4 65-160/0.75R QQPFF

Customer	Date 2024-06-16	Company
Contact	Item no.	Issued by
Phone	Project	Phone
E-mail	Project ID Proiect redenumit 2024-06-16 15:45:44	E-mail

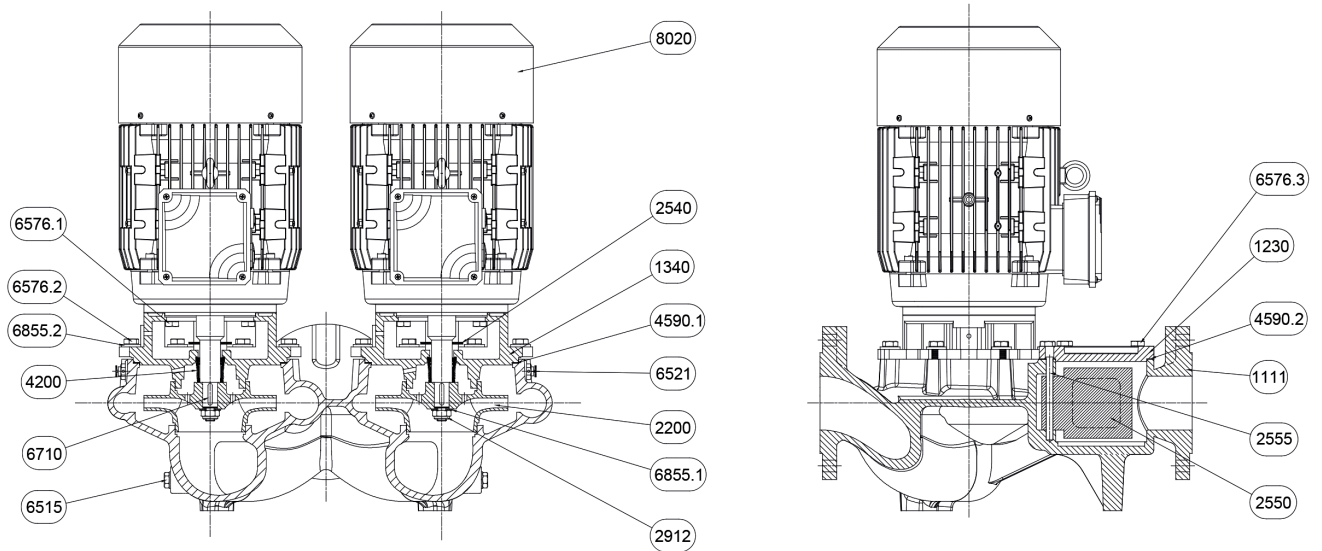

N°	PART NAME	MATERIAL	Q.TY
1111	Pump casing	EN-GJL-200	1
1230	Inspection cover	EN-GJL-200	1
1340	Latern-Cover	EN-GJL-200	2
2200	Impeller	EN-GJL-200	2
2540	Baffle	NB 70	2
2550	Shutter	EPDM 70	1
2555	Shutter pivot	AISI 420	1
2912	Impeller nut	6.8-ZN	2
4200	Mechanical seal	Sic/Sic/NBR/AISI 304	2
4590.1	Gasket	AF 1600	2
4590.2	Gasket	AF 1600	1
6515	Drain plug	EN-GJMB-350-10	2
6521	Vent valve	CW509L	2
6376.1	Hexagonal head screw	8.8-ZN	8
6376.2	Hexagonal head screw	8.8-ZN	16
6372.3	Hexagonal head screw	8.8-ZN	4
6710	Key	C50	2
6855.1	Impeller washer	R40-ZN	2
6855.2	Washer	R40-ZN	16
8020	Motor		2

(2/2)

Construction

Pump name LPCD4 65-160/0.75R QQPFF

Customer	Date 2024-06-16	Company
Contact	Item no.	Issued by
Phone	Project	Phone
E-mail	Project ID Proiect redenumit 2024-06-16 15:45:44	E-mail



Ref.	Name	Material
A	Rotary seal ring	Carbon
B	Stationary seal ring	Silicon Carbide
C	Gasket	EPDM
D	Bellows	EPDM
E	Spring plate	AISI 304
F	Spring	AISI 304
G	Spring plate	AISI 304