

# Technical Data

Pump Name

LPCD 50-125/3.06 QQPFF

Customer	Date	2024-07-02	Company
Contact	Item no.		Issued by
Phone	Project		Phone
E-mail	Project ID	Proiect redenumit 2024-07-02 22:34:28	E-mail

## Requested data

1	Pump type	CENTRIFUGAL PUMPS	Fluid	Water
2	Number of pumps / Reserve	1 / 0	Liquid temperature	°C
3	Flow	m³/h	Kin. viscosity	mm²/s
4	Head	m	Vapour pressure	bar
5	Geodetic head	m	PH value	
6	Inlet pressure (pin)	bar	Density	kg/m³
7	Available system NPSH		Solids	Weight %
8	Ambient temperature	°C		

## Pump

9	Pump Name	LPCD 50-125/3.06 QQPFF	Frequency	Hz	60	
10	Design	CENTRIFUGAL PUMPS	Installation type		STANDARD	
11	Manufacturer	EBARA	Impeller Diameter	Max.	mm	
12	Speed	rpm		3500	Designed	mm
13	No. of Stage			1	Min.	mm
14	Connection	Suction side	Flow	Operating	m³/h	
15	Connection	Discharge side		Max-	m³/h	36
16	Max Working Pressure	bar		10	Min-	m³/h
17	Shut-off head	bar	2.45	Head	Operating	m
18	Total weight	kg	See the table of "Dimensions".		- (Qmax.)	m
19	Shaft power	kW			- (Qmin.)	m
20			Max. Shaft Power at max. impeller	kW	2.70	
21	Required pump NPSH	m	Efficiency	%		

## Materials

22	Impeller	EN-GJL-200		
23	Intermediate casing	EN-GJL-200		
24	Bottom casing	EN-GJL-200		
25	Shaft	Stainless steel		
26	Gasket	AF1600		
27				

## Motor

28	Manufacturer	LAFERT	Insulation class	F	
29	Type	TEFC_LPCD 50-125/3.06_265_Three Phase	Phases	3~	
30	Specific design	IE2 / 60 Hz / Pole pairs 1	Frame size	100	
31	Rated power	kW	3	Weight	kg
32	Number of poles		2	Electric voltage	V
33	Speed	rpm	3505	Electric current	A
34	Degree of protection		IP 55		
35					

## Remarks

# Performance Curve

Pump Name

LPCD 50-125/3.06 QQPFF

Customer	Date	2024-07-02	Company
Contact	Item no.		Issued by
Phone	Project		Phone
E-mail	Project ID	Project redenumit 2024-07-02 22:34:28	E-mail

## Requested data

1	Flow	m³/h	
2	Head	m	
3	Geodetic head	m	

## Pump

Operating flow	m³/h		Frequency	Hz	60
Operating head	m		Number of poles		2
Impeller diameter designed	mm	120	Speed	rpm	3500

Test standard: ISO 9906:2012 - Grade3B

Water; 20°C; 998.3kg/m³; 1mm²/s

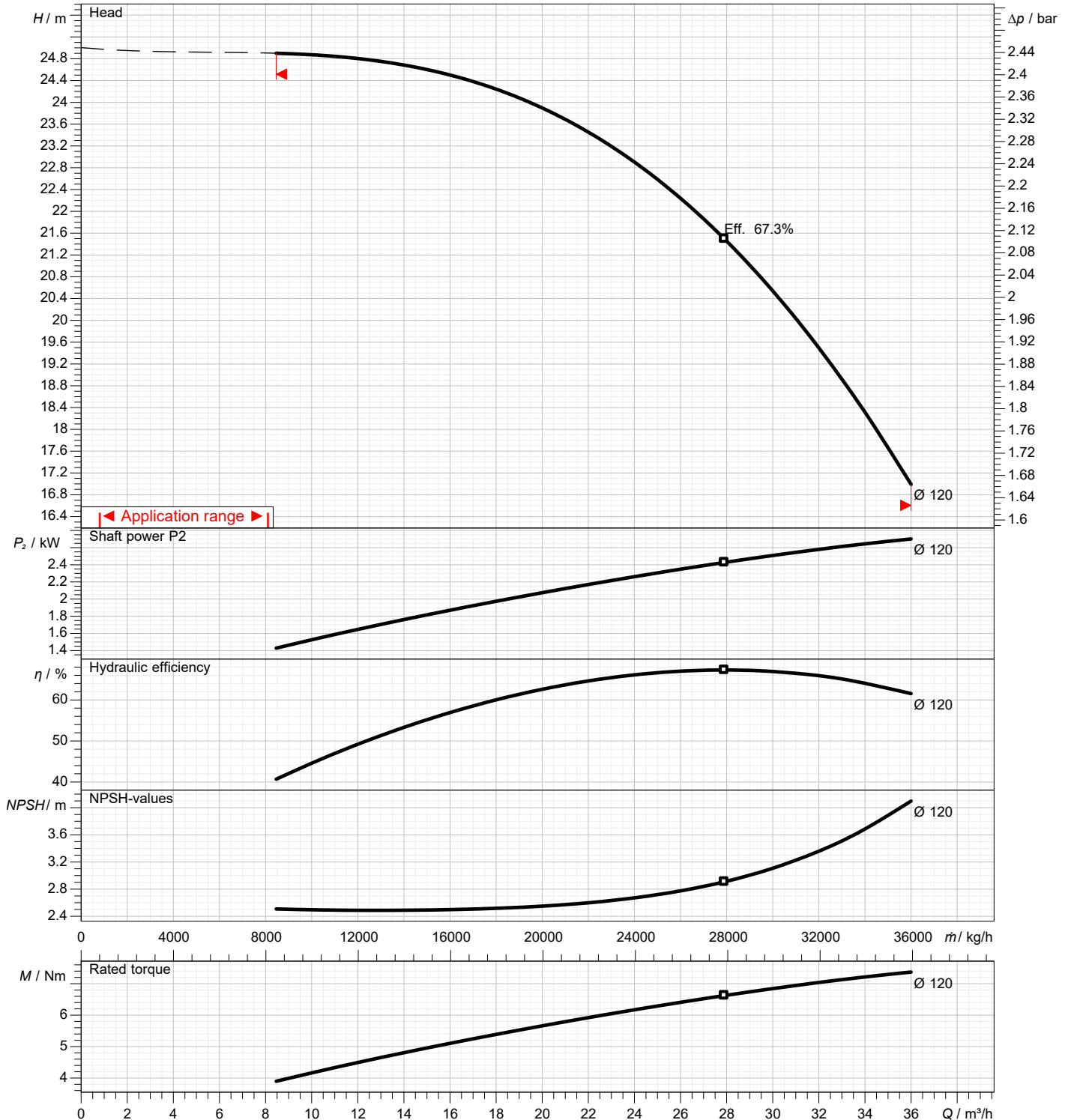

# Dimensions

Pump name **LPCD 50-125/3.06 QQPFF**

Customer	Date 2024-07-02	Company
Contact	Item no.	Issued by
Phone	Project	Phone
E-mail	Project ID Proiect redenumit 2024-07-02 22:34:28	E-mail

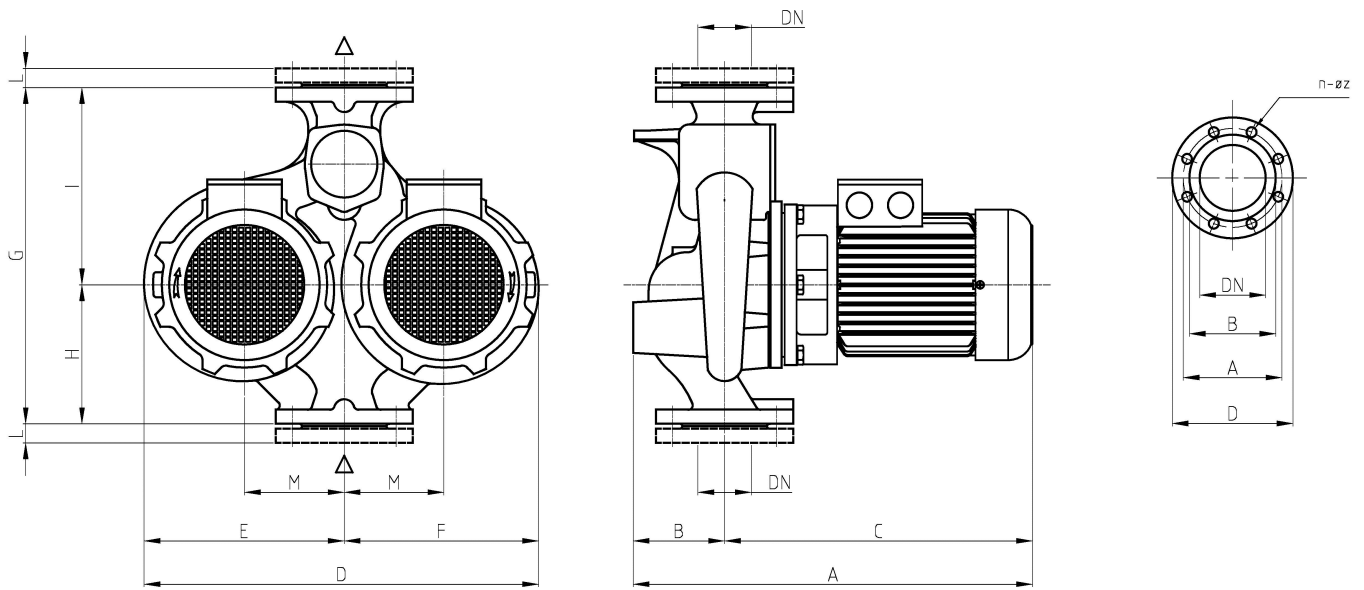

Dimensions in		mm						
1	A	530	L	22				
2	B	110	M	105				
3	C	420	Weight P&M	[76].6 kg				
4	D	427						
5	Dia A	125						
6	Dia B	102						
7	Dia D	165						
8	Dia DN	50						
9	Dia n	4						
10	Dia Z	18						
11	E	217						
12	F	210						
13	G	365						
14	H	145						
15	I	220						

(1/2)

# Construction

Pump name LPCD 50-125/3.06 QQPFF

Customer	Date 2024-07-02	Company
Contact	Item no.	Issued by
Phone	Project	Phone
E-mail	Project ID Proiect redenumit 2024-07-02 22:34:28	E-mail

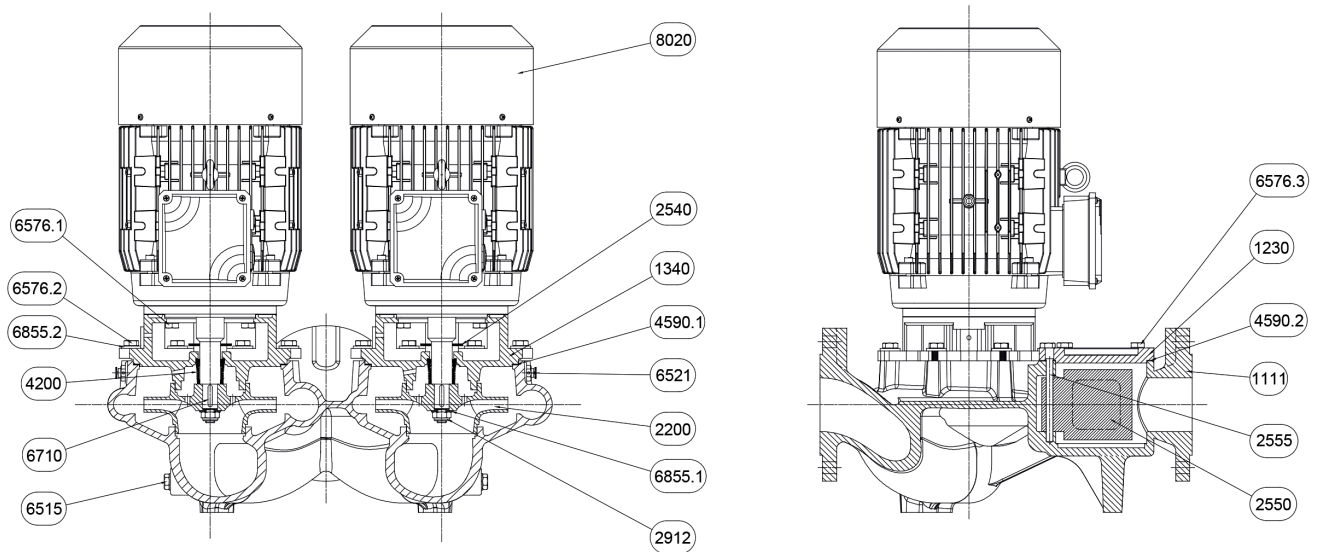

N°	PART NAME	MATERIAL	Q.TY
1111	Pump casing	EN-GJL-200	1
1230	Inspection cover	EN-GJL-200	1
1340	Latern-Cover	EN-GJL-200	2
2200	Impeller	EN-GJL-200	2
2540	Baffle	NB 70	2
2550	Shutter	EPDM 70	1
2555	Shutter pivot	AISI 420	1
2912	Impeller nut	6.8-ZN	2
4200	Mechanical seal	Sic/Sic/NBR/AISI 304	2
4590.1	Gasket	AF 1600	2
4590.2	Gasket	AF 1600	1
6515	Drain plug	EN-GJMB-350-10	2
6521	Vent valve	CW509L	2
6376.1	Hexagonal head screw	8.8-ZN	8
6376.2	Hexagonal head screw	8.8-ZN	8
6372.3	Hexagonal head screw	8.8-ZN	4
6710	Key	C50	2
6855.1	Impeller washer	R40-ZN	2
6855.2	Washer	R40-ZN	8
8020	Motor		2

(2/2)

# Construction

Pump name LPCD 50-125/3.06 QQPFF

Customer	Date 2024-07-02	Company
Contact	Item no.	Issued by
Phone	Project	Phone
E-mail	Project ID Proiect redenumit 2024-07-02 22:34:28	E-mail



Ref.	Name	Material
A	Rotary seal ring	Carbon
B	Stationary seal ring	Silicon Carbide
C	Gasket	EPDM
D	Bellows	EPDM
E	Spring plate	AISI 304
F	Spring	AISI 304
G	Spring plate	AISI 304