

Technical Data

Pump Name

LPC 100-250/37 QQPFF

Customer	Date	2024-06-16	Company
Contact	Item no.		Issued by
Phone	Project		Phone
E-mail	Project ID	Proiect redenumit 2024-06-16 15:45:44	E-mail

Requested data

1	Pump type	CENTRIFUGAL PUMPS	Fluid	Water
2	Number of pumps / Reserve	1 / 0	Liquid temperature	°C 20
3	Flow m³/h		Kin. viscosity	mm²/s 1.005
4	Head m		Vapour pressure	bar 0.0234
5	Geodetic head m		PH value	
6	Inlet pressure (pin) bar	0	Density	kg/m³ 998.3
7	Available system NPSH		Solids	Weight % 0
8	Ambient temperature °C	20		

Pump

9	Pump Name	LPC 100-250/37 QQPFF	Frequency	Hz 50
10	Design	CENTRIFUGAL PUMPS	Installation type	STANDARD
11	Manufacturer	EBARA	Impeller Diameter	Max. mm 226
12	Speed rpm	2900		Designed mm 226
13	No. of Stage	1		Min. mm 226
14	Connection Suction side		Flow	Operating m³/h
15	Connection Discharge side			Max- m³/h 210
16	Max Working Pressure bar	10		Min- m³/h 48
17	Shut-off head bar	6.71	Head	Operating m
18	Total weight kg	See the table of "Dimensions".		- (Qmax.) m 46.7
19	Shaft power kW			- (Qmin.) m 68.1
20			Max. Shaft Power at max. impeller	kW 36.03
21	Required pump NPSH m		Efficiency	%

Materials

22	Impeller	EN-GJL-200	
23	Intermediate casing	EN-GJL-200	
24	Bottom casing	EN-GJL-200	
25	Shaft	Stainless steel	
26	Gasket	AF1600	
27			

Motor

28	Manufacturer	ABLE	Insulation class	F
29	Type	TEFC_LPC 100-250/37_400_Three Phase	Phases	3~
30	Specific design	IE3 / 50 Hz / Pole pairs 1	Frame size	200
31	Rated power kW	37	Weight	kg
32	Number of poles	2	Electric voltage	V 400
33	Speed rpm	2950	Electric current	A 64.9
34	Degree of protection	IP 55		
35				

Remarks

Performance Curve

Pump Name

LPC 100-250/37 QQPFF

Customer	Date	2024-06-16	Company
Contact	Item no.		Issued by
Phone	Project		Phone
E-mail	Project ID	Project redenumit 2024-06-16 15:45:44	E-mail

Requested data

1	Flow	m³/h	
2	Head	m	
3	Geodetic head	m	

Pump

Operating flow	m³/h		Frequency	Hz	50
Operating head	m		Number of poles		2
Impeller diameter designed	mm	226	Speed	rpm	2900

Test standard: ISO 9906:2012 - Grade3B

Water; 20°C; 998.3kg/m³; 1mm²/s

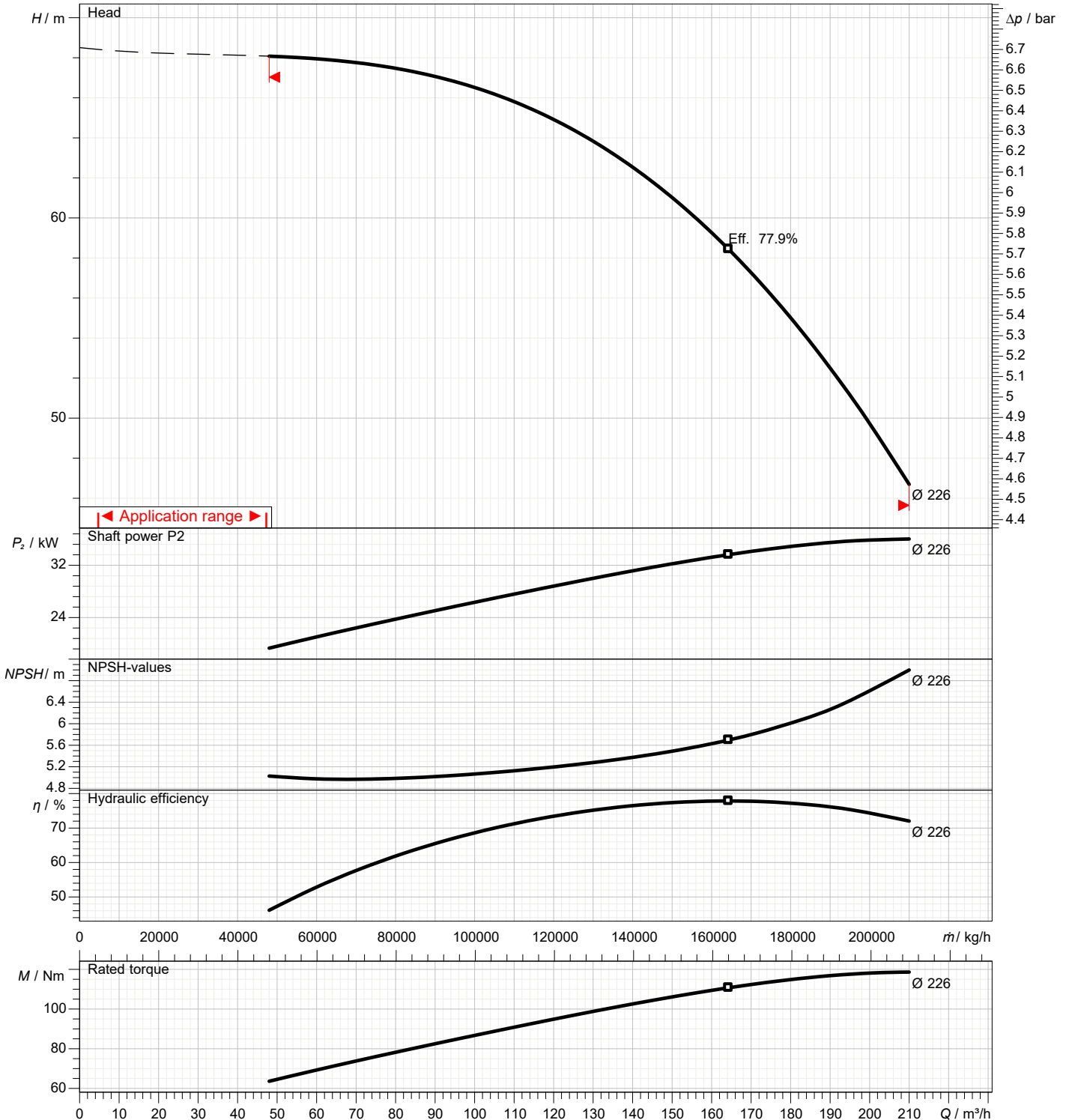

Dimensions

Pump name **LPC 100-250/37 QQPFF**

Customer	Date 2024-06-16	Company
Contact	Item no.	Issued by
Phone	Project	Phone
E-mail	Project ID Proiect redenumit 2024-06-16 15:45:44	E-mail

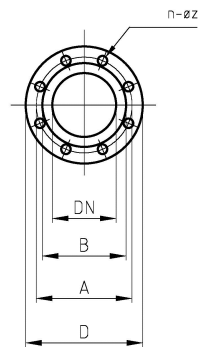
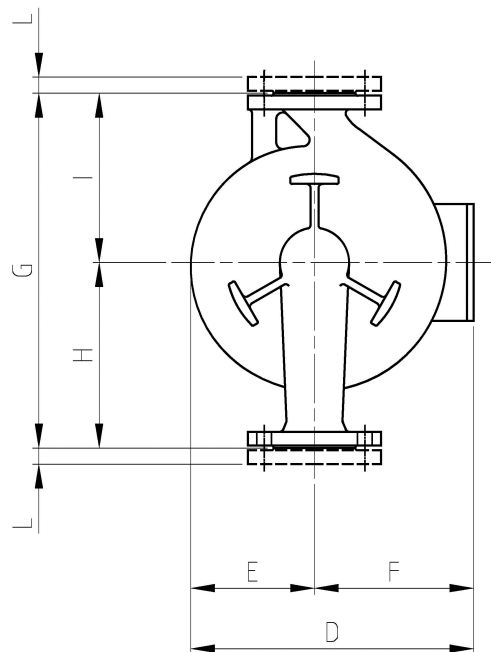
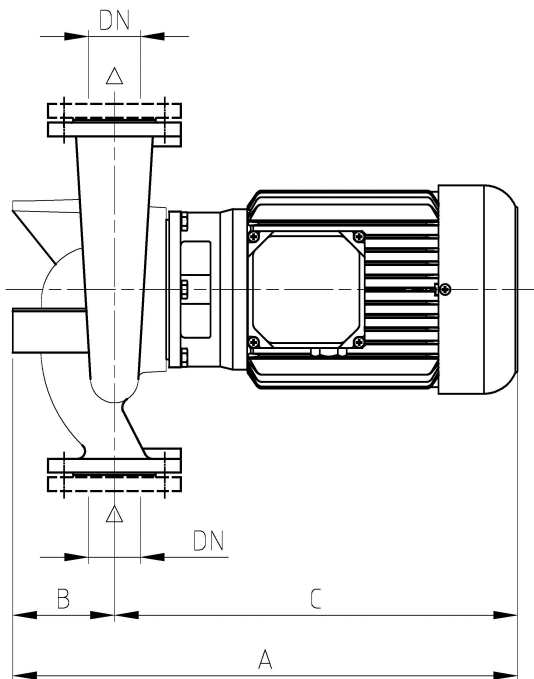

Dimensions in		mm					
1	A	1047	L	26			
2	B	190	Weight P&M	327 kg			
3	C	857					
4	D	481					
5	Dia A	180					
6	Dia B	158					
7	Dia D	220					
8	Dia DN	100					
9	Dia n	8					
10	Dia Z	18					
11	E	176					
12	F	305					
13	G	600					
14	H	320					
15	I	280					

(1/2) Construction

Pump name LPC 100-250/37 QQPFF

Customer	Date 2024-06-16	Company
Contact	Item no.	Issued by
Phone	Project	Phone
E-mail	Project ID Proiect redenumit 2024-06-16 15:45:44	E-mail

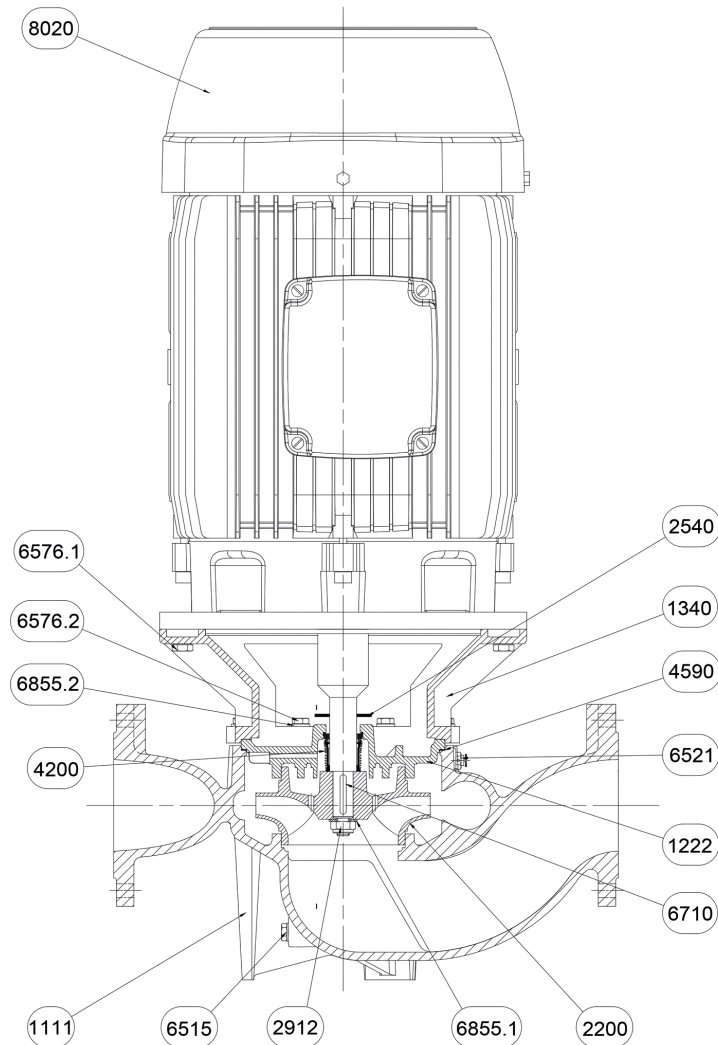

N°	PART NAME	MATERIAL	Q.TY
1111	Pump casing	EN-GJL-200	1
1222	Gland cover	EN-GJL-200	1
1340	Latern	EN-GJL-200	1
2200	Impeller	EN-GJL-200	1
2540	Baffle	NB 70	1
2912	Impeller nut	6.8-ZN	1
4200	Mechanica sela	Sic/Sic/NBR/AISI 304	1
4590	Gasket	AF 1600	1
6515	Drain plug	EN-GJMB-350-10	1
6521	Vent valve	CW509L	1
6576.1	Hexagonal head screw	8.8-ZN	4
6576.2	Hexagonal head screw	8.8-ZN	12
6710	Key	C50	1
6855.1	Impeller washer	R40-ZN	1
6855.2	Washer	R40-ZN	12
8020	Motor		1

(2/2)

Construction

Pump name LPC 100-250/37 QQPFF

Customer	Date 2024-06-16	Company
Contact	Item no.	Issued by
Phone	Project	Phone
E-mail	Project ID Proiect redenumit 2024-06-16 15:45:44	E-mail

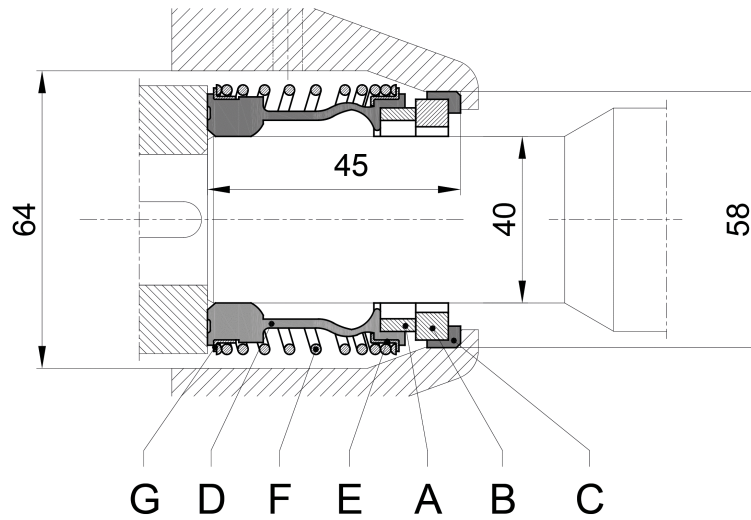

Ref.	Name	Material
A	Rotary seal ring	Carbon
B	Stationary seal ring	Silicon Carbide
C	Gasket	EPDM
D	Bellows	EPDM
E	Spring plate	AISI 304
F	Spring	AISI 304
G	Spring plate	AISI 304