

Technical Data

Pump Name

LPC 65-125/3.0 QQPFF

Customer	Date	2024-06-16	Company
Contact	Item no.		Issued by
Phone	Project		Phone
E-mail	Project ID	Proiect redenumit 2024-06-16 15:45:44	E-mail

Requested data

1	Pump type	CENTRIFUGAL PUMPS	Fluid	Water
2	Number of pumps / Reserve	1 / 0	Liquid temperature	°C
3	Flow	m³/h	Kin. viscosity	mm²/s
4	Head	m	Vapour pressure	bar
5	Geodetic head	m	PH value	
6	Inlet pressure (pin)	bar	Density	kg/m³
7	Available system NPSH		Solids	Weight %
8	Ambient temperature	°C		

Pump

9	Pump Name	LPC 65-125/3.0 QQPFF	Frequency	Hz	50	
10	Design	CENTRIFUGAL PUMPS	Installation type		STANDARD	
11	Manufacturer	EBARA	Impeller Diameter	Max.	mm	
12	Speed	rpm		2900	Designed	mm
13	No. of Stage	1		Min.	mm	128
14	Connection	Suction side	Flow	Operating	m³/h	
15	Connection	Discharge side		Max-	m³/h	60
16	Max Working Pressure	bar		10	Min-	m³/h
17	Shut-off head	bar	2.20	Head	Operating	m
18	Total weight	kg	See the table of "Dimensions".		- (Qmax.)	m
19	Shaft power	kW			- (Qmin.)	m
20			Max. Shaft Power at max. impeller	kW	3.01	
21	Required pump NPSH	m	Efficiency	%		

Materials

22	Impeller	EN-GJL-200		
23	Intermediate casing	EN-GJL-200		
24	Bottom casing	EN-GJL-200		
25	Shaft	Stainless steel		
26	Gasket	AF1600		
27				

Motor

28	Manufacturer	LAFERT	Insulation class	F	
29	Type	TEFC_LPC 65-125/3.0_230_Three Phase	Phases	3~	
30	Specific design	IE3 / 50 Hz / Pole pairs 1	Frame size	100	
31	Rated power	kW	3	Weight	kg
32	Number of poles	2	Electric voltage	V	230
33	Speed	rpm	2900	Electric current	A
34	Degree of protection	IP 55			
35					

Remarks

Performance Curve

Pump Name

LPC 65-125/3.0 QQPFF

Customer	Date	2024-06-16	Company
Contact	Item no.		Issued by
Phone	Project		Phone
E-mail	Project ID	Proiect redenumit 2024-06-16 15:45:44	E-mail

Requested data

1	Flow	m³/h	
2	Head	m	
3	Geodetic head	m	

Pump

Operating flow	m³/h		Frequency	Hz	50
Operating head	m		Number of poles		2
Impeller diameter designed	mm	128	Speed	rpm	2900

Test standard: ISO 9906:2012 - Grade3B

Water; 20°C; 998.3kg/m³; 1mm²/s

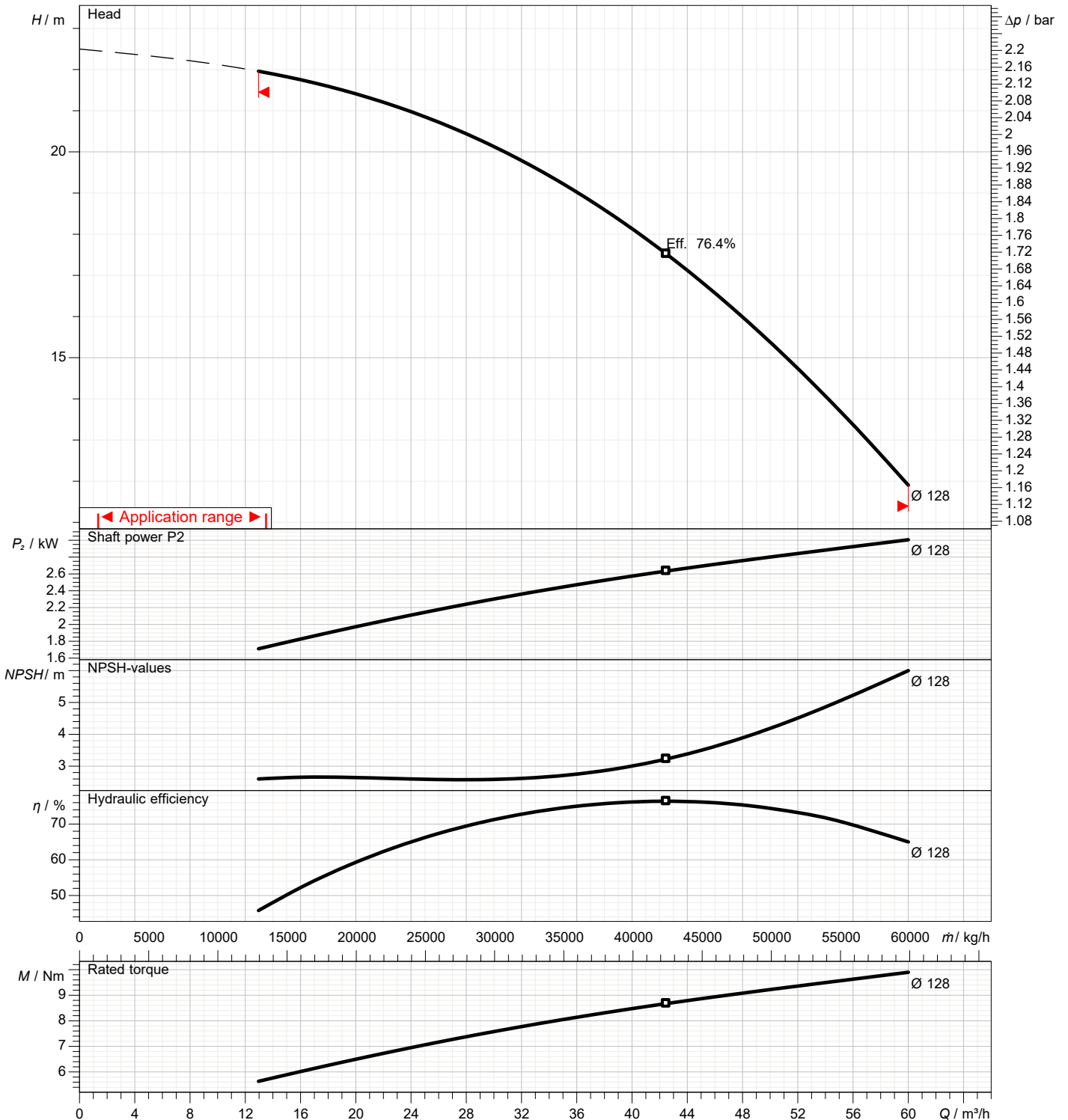

Dimensions

Pump name **LPC 65-125/3.0 QQPFF**

Customer	Date 2024-06-16	Company
Contact	Item no.	Issued by
Phone	Project	Phone
E-mail	Project ID Proiect redenumit 2024-06-16 15:45:44	E-mail



Dimensions in		mm							
1	A	560	L	22					
2	B	140	Weight P&M	44,3 kg					
3	C	420							
4	D	253							
5	Dia A	145							
6	Dia B	122							
7	Dia D	185							
8	Dia DN	65							
9	Dia n	4							
10	Dia Z	18							
11	E	108							
12	F	145							
13	G	360							
14	H	205							
15	I	155							

(1/2) Construction

Pump name **LPC 65-125/3.0 QQPFF**

Customer	Date 2024-06-16	Company
Contact	Item no.	Issued by
Phone	Project	Phone
E-mail	Project ID Proiect redenumit 2024-06-16 15:45:44	E-mail

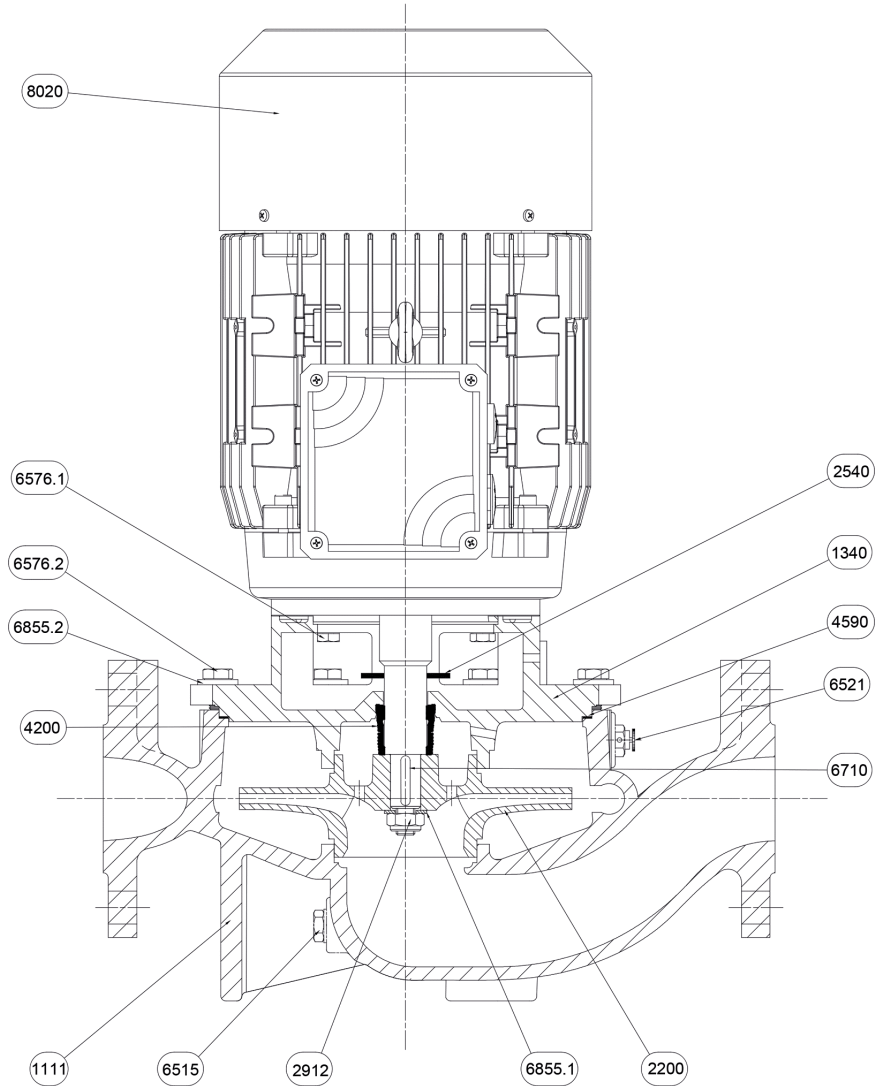

N°	PART NAME	MATERIAL	Q.TY
1111	Pump casing	EN-GJL-200	1
1340	Latern-Cover	EN-GJL-200	1
2200	Impeller	EN-GJL-200	1
2540	Baffle	NB 70	1
2912	Impeller nut	6.8-ZN	1
4200	Mechanical seal	Sic/Sic/NBR/AISI 304	1
4590	Gasket	AF 1600	1
6515	Drain plug	EN-GJMB-350-10	1
6521	Vent valve	CW509L	1
6576.1	Hexagonal head screw	8.8-ZN	4
6576.2	Hexagonal head screw	8.8-ZN	4
6710	Key	C50	1
6855.1	Impeller washer	R40-ZN	1
6855.2	Washer	R40-ZN	4
8020	Motor		1

(2/2)

Construction

Pump name LPC 65-125/3.0 QQPFF

Customer	Date 2024-06-16	Company
Contact	Item no.	Issued by
Phone	Project	Phone
E-mail	Project ID Proiect redenumit 2024-06-16 15:45:44	E-mail



Ref.	Name	Material
A	Rotary seal ring	Carbon
B	Stationary seal ring	Silicon Carbide
C	Gasket	EPDM
D	Bellows	EPDM
E	Spring plate	AISI 304
F	Spring	AISI 304
G	Spring plate	AISI 304