

Technical Data

Pump Name

LPS 32/40 M

Customer	Date	2024-06-16	Company
Contact	Item no.		Issued by
Phone	Project		Phone
E-mail	Project ID	Proiect redenumit 2024-06-16 15:45:44	E-mail

Requested data

1	Pump type	IN LINE CENTRIFUGAL PUMPS	Fluid	Water
2	Number of pumps / Reserve	1 / 0	Liquid temperature	°C
3	Flow	m³/h	Kin. viscosity	mm²/s
4	Head	m	Vapour pressure	bar
5	Geodetic head	m	PH value	
6	Inlet pressure (pin)	bar	Density	kg/m³
7	Available system NPSH		Solids	Weight %
8	Ambient temperature	°C		

Pump

9	Pump Name	LPS 32/40 M	Frequency	Hz	50	
10	Design	IN LINE CENTRIFUGAL PUMPS	Installation type		STANDARD	
11	Manufacturer	EBARA	Impeller Diameter	Max.	mm	
12	Speed	rpm		2800	Designed	mm
13	No. of Stage	1		Min.	mm	124
14	Connection	Suction side	Flow	Operating	m³/h	
15	Connection	Discharge side		Max-	m³/h	9
16	Max Working Pressure	bar		10	Min-	m³/h
17	Shut-off head	bar	1.61	Head	Operating	m
18	Total weight	kg	See the table of "Dimensions".		- (Qmax.)	m
19	Shaft power	kW			- (Qmin.)	m
20			Max. Shaft Power at max. impeller	kW	0.41	
21	Required pump NPSH	m	Efficiency	%		

Materials

22	Impeller	AISI 304		
23	Casing	AISI 304		
24	Shaft	AISI 303 (wet extension)		
25				
26				
27				

Motor

28	Manufacturer	EPE Standard	Insulation class	F	
29	Type	TEFC_LPS 32/40 M_230_Single Phase	Phases	1~	
30	Specific design	IE2 / 50 Hz / Pole pairs 1	Frame size		
31	Rated power	kW	0.4	Weight	kg
32	Number of poles	2	Electric voltage	V	230
33	Speed	rpm	2800	Electric current	A
34	Degree of protection	IP 55			
35					

Remarks

Performance Curve

Pump Name

LPS 32/40 M

Customer	Date	2024-06-16	Company
Contact	Item no.		Issued by
Phone	Project		Phone
E-mail	Project ID	Project redenumit 2024-06-16 15:45:44	E-mail

Requested data

1	Flow	m³/h	
2	Head	m	
3	Geodetic head	m	

Pump

Operating flow	m³/h		Frequency	Hz	50
Operating head	m		Number of poles		2
Impeller diameter designed	mm	124	Speed	rpm	2800

Test standard: ISO 9906:2012 - Grade3B

Water; 20°C; 998.3kg/m³; 1mm²/s

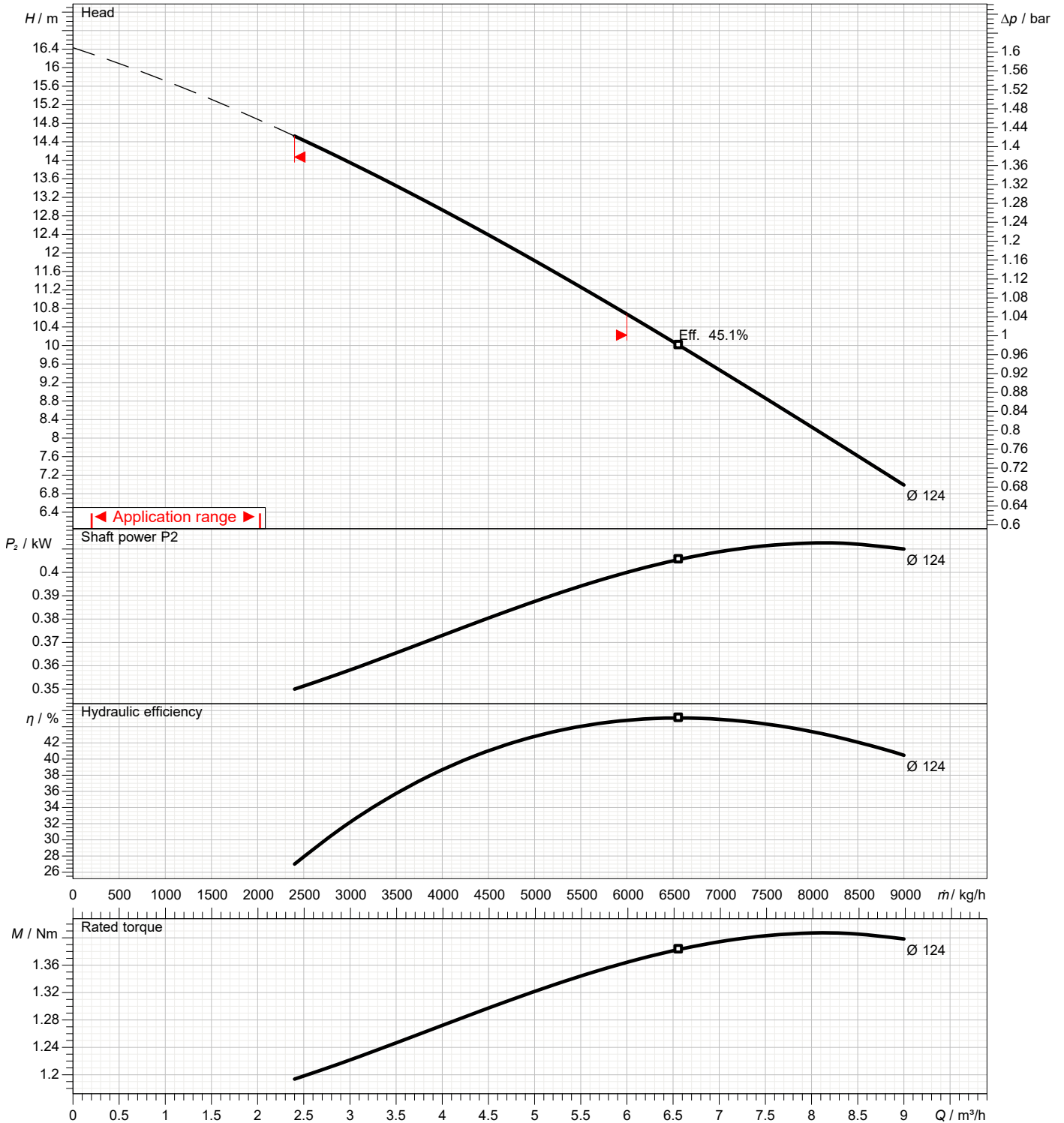

Dimensions

Pump Name LPS 32/40 M

Customer	Date 2024-06-16	Company
Contact	Item no.	Issued by
Phone	Project	Phone
E-mail	Project ID Proiect redenumit 2024-06-16 15:45:44	E-mail

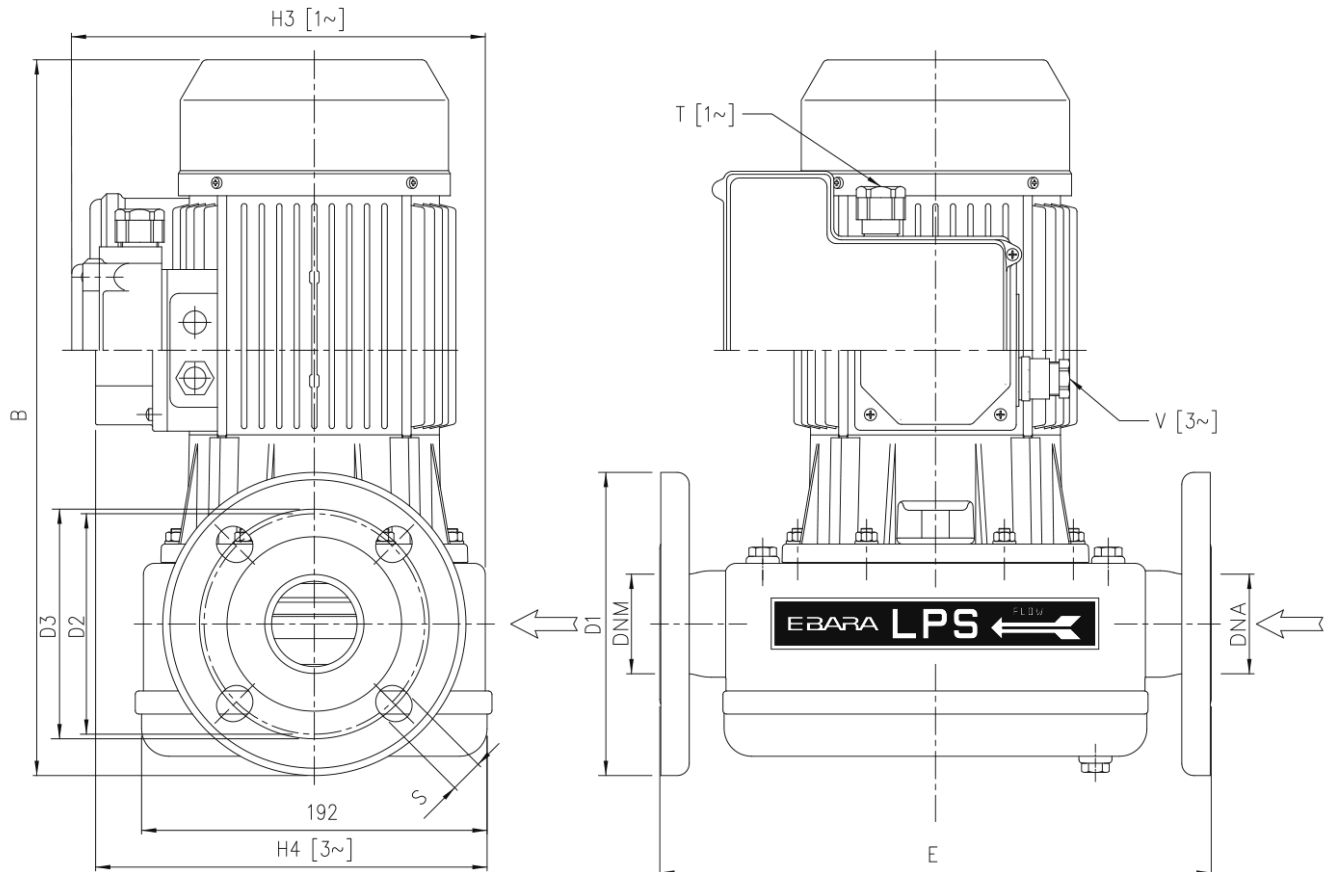

Dimensions in		mm						
1	B	341.5						
2	D1	140						
3	D2	100						
4	D3	100						
5	DNA	32						
6	DNM	32						
7	E	305						
8	H3	206						
9	S	18						
10	T	PG 11						
11	Weight P&M	14.7 kg						
12								
13								
14								
15								

(1/3)

Construction

Pump Name LPS 32/40 M

Customer	Date 2024-06-16	Company
Contact	Item no.	Issued by
Phone	Project	Phone
E-mail	Project ID Proiect redenumit 2024-06-16 15:45:44	E-mail

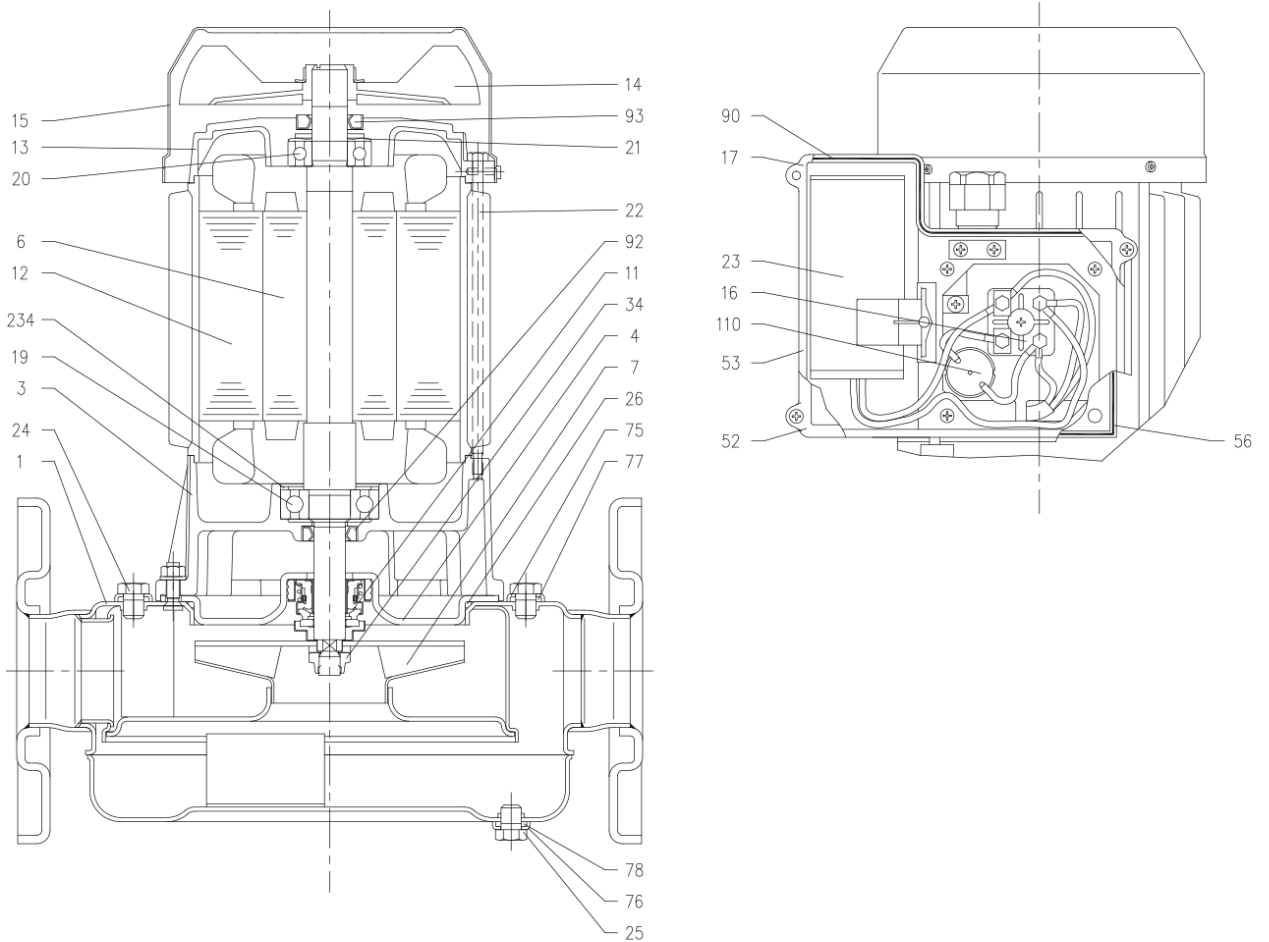

(2/3)

Construction

Pump Name LPS 32/40 M

Customer	Date	2024-06-16	Company
Contact	Item no.		Issued by
Phone	Project		Phone
E-mail	Project ID	Proiect redenumit 2024-06-16 15:45:44	E-mail

N°	PART NAME	MATERIAL	DIMENSION	STANDARD
1	Casing	AISI 304		
3	Motor bracket	Aluminium		
4	Casing cover	AISI 304		
6	Shaft w ith rotor	AISI 303 (Wet extension)		
7	Impeller	AISI 304		
11	Mechanical seal [4]	Carbon/Ceramic/NBRH		
12	Motor frame w ith stator	-		
13	Motor cover	Aluminium		
14	Fan	PA		
15	Fan cover	Fe P04 Galvanized		
16	Terminal board	-		
17	Terminal box cover [2]	Aluminium		
19	Pump side ball bearing	-		
20	Fan side ball bearing	-		
21	Adjusting ring	Steel C70		
22	Tie rod	Fe 420 Galvanized		
23	Capacitor [1]	-		
24	Priming plug	AISI 304	1/8" G	ISO 228/2
25	Drain plug	AISI 304	1/8" G	ISO 228/2
26	O-ring	NBR		
34	Impeller nut	AISI 304	M10x1.25	UNI 7474
52	Capacitor box [1]	ABS class V-0		
53	Capacitor box cover [1]	ABS class V-0		
56	Box gasket	NBR		
75	Washer	AISI 304		
76	Washer	AISI 304		
77	O-ring	NBR		
78	O-ring	NBR		
90	Terminal box cover gasket	NBR		
92	Lip seal	NBR		
93	Lip seal	NBR		
110	Protector [3]	-		
234	Seeger ring	Carbon steel		

- [1] Only for single phase
- [2] Only for three phase
- [3] Only for version single phase: LPS 50/150M
- [4] See **CONSTRUCTION 3**

(3/3)

Construction

Pump Name LPS 32/40 M

Customer	Date 2024-06-16	Company
Contact	Item no.	Issued by
Phone	Project	Phone
E-mail	Project ID Proiect redenumit 2024-06-16 15:45:44	E-mail

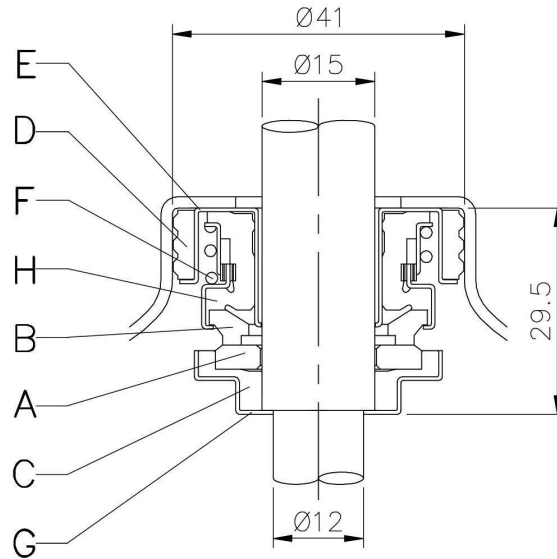

REF	PART NAME	MATERIAL
A	Rotary seal ring	ceramic
B	Stationary seal ring	carbon graphite
C	Cup Gasket	NBRH
D	Seal ring	NBRH
E	Case	AISI 304
F	Selfdriving spring	AISI 304
G	Case	AISI 304
H	Belows	NBRH