

Technical Data

Pump Name

MD 40-200/7.56

Customer	Date	2024-07-02	Company
Contact	Item no.		Issued by
Phone	Project		Phone
E-mail	Project ID	Proiect redenumit 2024-07-02 22:34:28	E-mail

Requested data

1	Pump type	CENTRIFUGAL PUMPS	Fluid	Water
2	Number of pumps / Reserve	1 / 0	Liquid temperature	°C 20
3	Flow m³/h		Kin. viscosity	mm²/s 1.005
4	Head m		Vapour pressure	bar 0.0234
5	Geodetic head m		PH value	
6	Inlet pressure (pin) bar	0	Density	kg/m³ 998.3
7	Available system NPSH		Solids	Weight % 0
8	Ambient temperature °C	20		

Pump

9	Pump Name	MD 40-200/7.56	Frequency	Hz 60
10	Design	CENTRIFUGAL PUMPS	Installation type	STANDARD
11	Manufacturer	EBARA	Impeller Diameter	Max. mm 200
12	Speed rpm	3450		Designed mm 200
13	No. of Stage	1		Min. mm 200
14	Connection Suction side	DIN 2532	Flow	Operating m³/h
15	Connection Discharge side	DIN 2532		Max- m³/h 36
16	Max Working Pressure bar			Min- m³/h 6
17	Shut-off head bar	5.73	Head	Operating m
18	Total weight kg	See the table of "Dimensions".		- (Qmax.) m 43.0
19	Shaft power kW			- (Qmin.) m 58.2
20			Max. Shaft Power at max. impeller	kW 7.26
21	Required pump NPSH m		Efficiency	%

Materials

22				
23				
24				
25				
26				
27				

Motor

28	Manufacturer	EPE Standard	Insulation class	F
29	Type	TEFC_MD 40-200/7.56_380_Three Phase	Phases	3~
30	Specific design	- / 60 Hz / Pole pairs 1	Frame size	
31	Rated power kW	7.5	Weight	kg
32	Number of poles	2	Electric voltage	V 380
33	Speed rpm	3450	Electric current	A 14.9
34	Degree of protection	IP 55		
35				

Remarks

Performance Curve

Pump Name

MD 40-200/7.56

Customer	Date	2024-07-02	Company
Contact	Item no.		Issued by
Phone	Project		Phone
E-mail	Project ID	Project redenumit 2024-07-02 22:34:28	E-mail

Requested data

1	Flow	m³/h	
2	Head	m	
3	Geodetic head	m	

Pump

Operating flow	m³/h		Frequency	Hz	60
Operating head	m		Number of poles		2
Impeller diameter designed	mm	200	Speed	rpm	3450

Test standard: ISO 9906:2012 - Grade3B

Water; 20°C; 998.3kg/m³; 1mm²/s

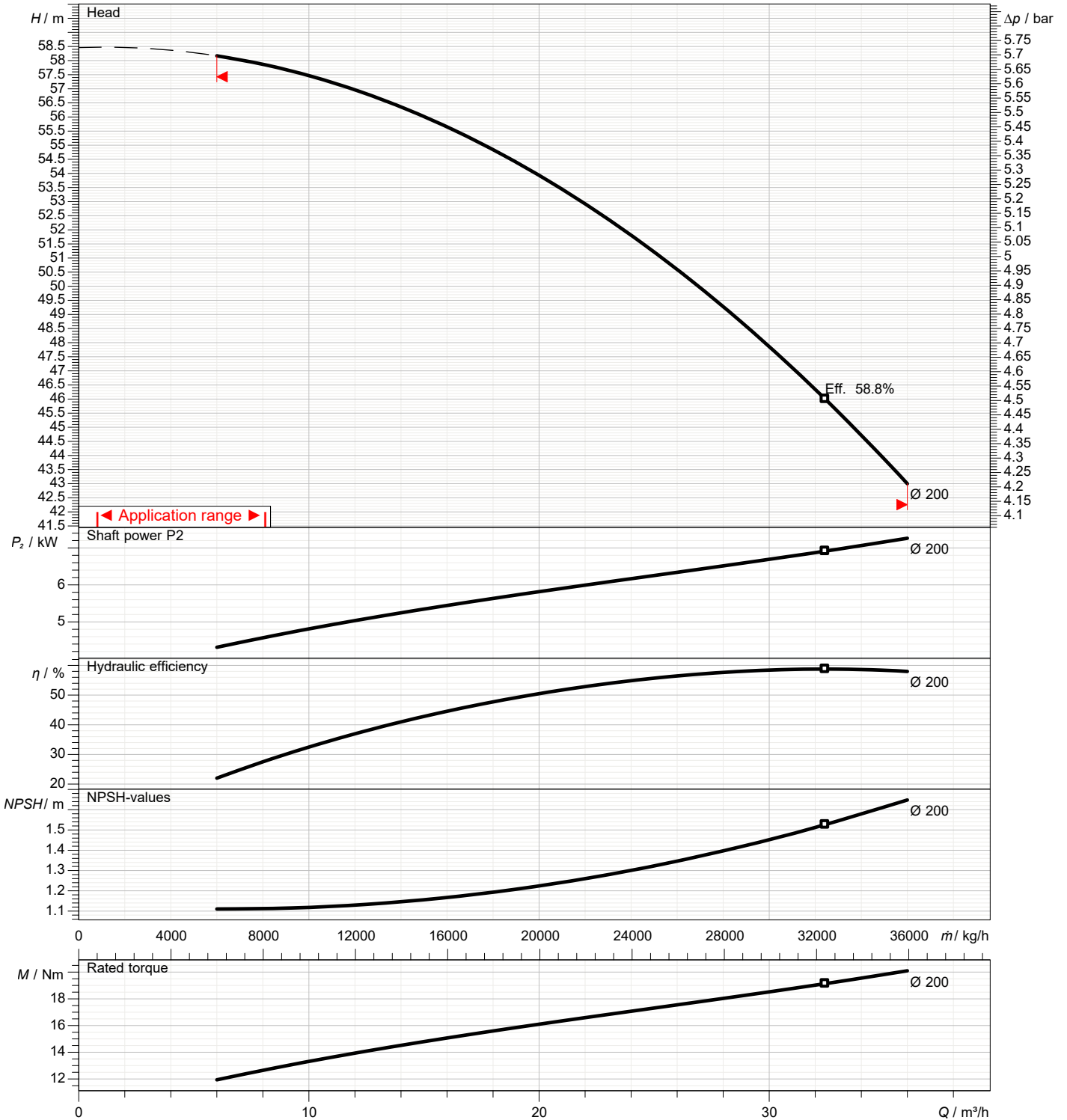

Dimensions

Pump name MD 40-200/7.56

Customer	Date 2024-07-02	Company
Contact	Item no.	Issued by
Phone	Project	Phone
E-mail	Project ID Proiect redenumit 2024-07-02 22:34:28	E-mail

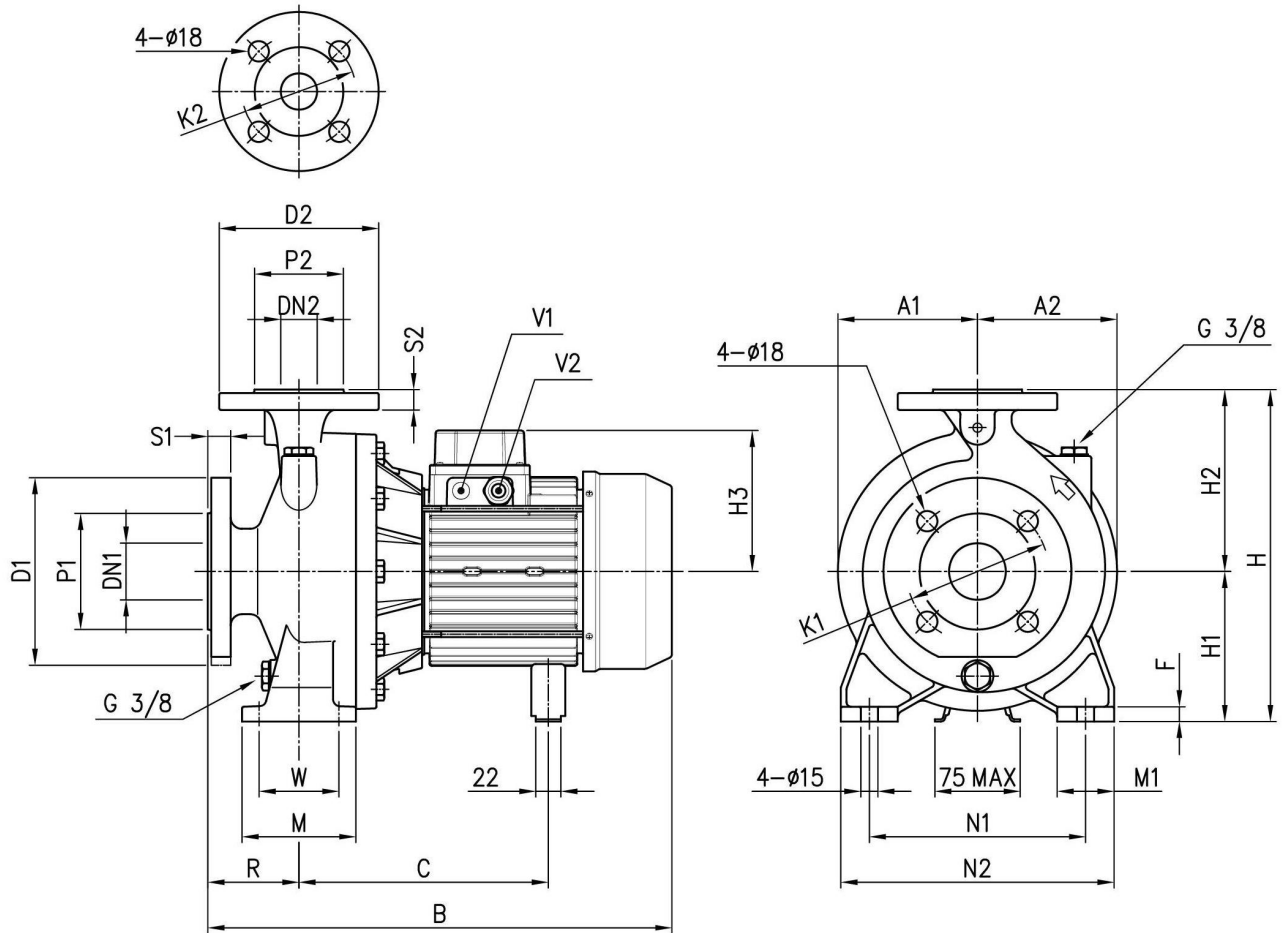

Dimensions in		mm		
1	A1	144	M	100
2	A2	144	M1	50
3	B	539	N1	212
4	C	275	N2	265
5	D1	185	P1	122
6	D2	150	P2	88
7	DN1	65	R	100
8	DN2	40	S1	20
9	F	13	S2	18
10	H	340	V1	[PG 13].5
11	H1	160	V2	PG 16
12	H2	180	W	70
13	H3	150	Weight kg	68
14	K1	145		
15	K2	110		

(1/2)

Construction

Pump name MD 40-200/7.56

Customer	Date 2024-07-02	Company
Contact	Item no.	Issued by
Phone	Project	Phone
E-mail	Project ID Proiect redenumit 2024-07-02 22:34:28	E-mail

UP TO 13 kW

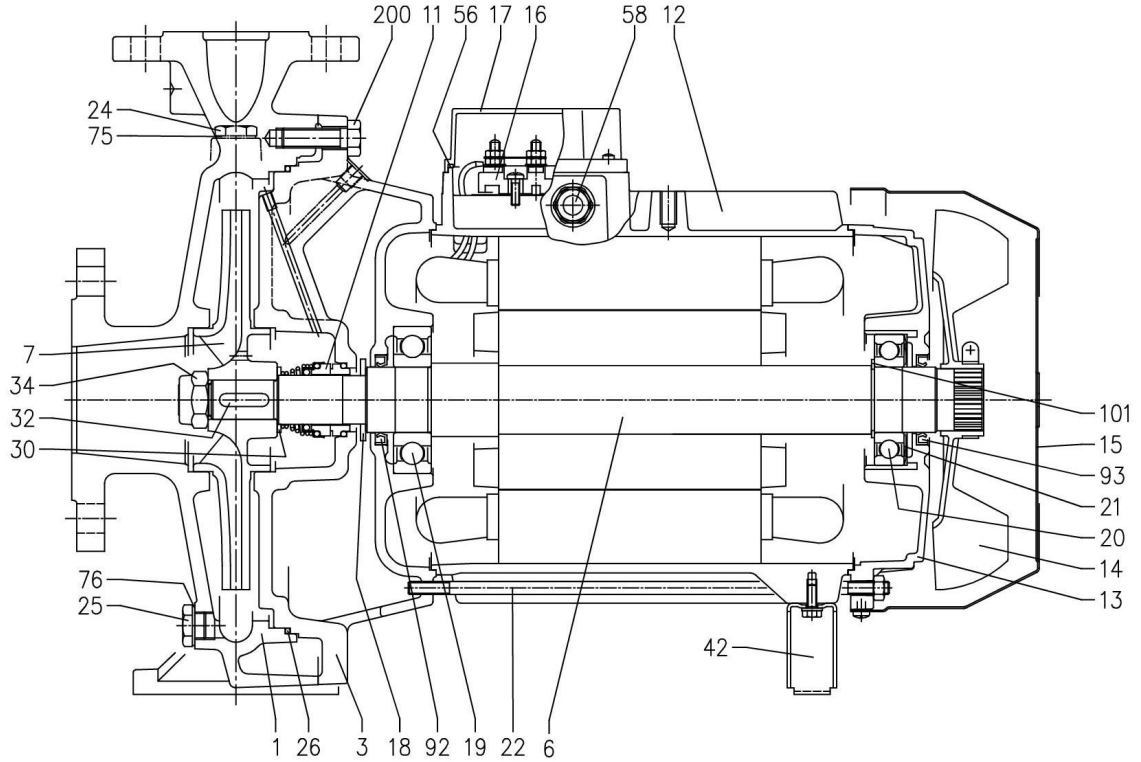

15 kW AND ABOVE (NO 65-160/156)

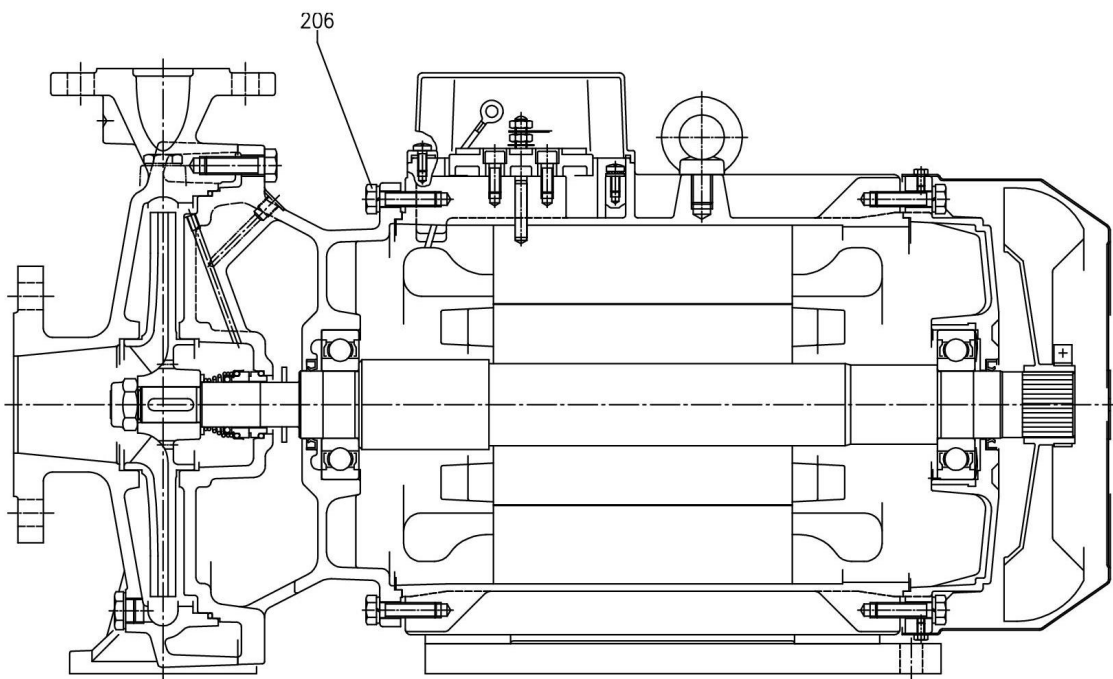

(2/2)

Construction

Pump name MD 40-200/7.56

Customer	Date	2024-07-02	Company
Contact	Item no.		Issued by
Phone	Project		Phone
E-mail	Project ID	Proiect redenumit 2024-07-02 22:34:28	E-mail

N°	PART NAME	MATERIAL	DIMENSIONS	STANDARD	N. FOR 1 UNIT	
1	Casing	Cast iron EN-GJL-200-EN 1561			1	
3	Motor bracket	Cast iron EN-GJL-200-EN 1561			1	
6	Shaft with rotor	AISI 304 (Part in contact with liquid)			1	
7	Impeller	Md xx-125, Md xx-160, Mdx-200	Cast iron EN-GJL-200-EN 1561		1	
		Md xx-250	Bronze			
11	Mechanical seal	Carbon/Ceramic/NBR			1	
12	Motor frame with stator	-			1	
13	Motor cover	Aluminium			1	
14	Fan	PP			1	
15	Fan cover	Fe P04 Zincate			1	
16	Terminal box	-			1	
17	Terminal box cover	Plastic [1] - Aluminium [2]			1	
18	Splash ring	Up to 7.5 kW	NBR	40x21.5x3	EPE DRAWING	
		9.2 kW and above		50x29.5x3		
19	Pump side ball bearing	-			1	
20	Fan side ball bearing	-			1	
21	Adjusting ring	Steel C70			1	
22	Tie rod	Up to 13 kW and MD 65-160/15	Fe 42 Zincate		EPE DRAWING	
	Screw	15kW and above	Zn. steel 8.8 strenght class ISO 898/1			
24	Priming plug	Brass		EPE DRAWING	1	
25	Drain plug	Brass		EPE DRAWING	1	
26	O-ring	Md xx-125	NBR	147x3,53	EPE DRAWING	
		Md xx-160		176x3,53		
		Md xx-200		220x3,53		
		Md xx-250		277x3,53		
30	Spacer	AISI 304	22,5x26,9x2,5 (up to 7,5kW) 30,5x40x2,5 (9,2 kW and above)	EPE DRAWING	1	
32	Key	AISI 316	6x6x25 (up to 7,5kW) 8x7x30 (9,2 kW and above)	UNI 6604	1	
34	Impeller nut	AISI 304	M16x1,5 (up to 7,5kW) M20x1,5 (9,2 kW and above)	UNI 7474	1	
42	Foot	Fe P04		EPE DRAWING	1	
56	Box gasket	NBR			1	
58	Cable entry[2]	-			1	
75	Washer	Aluminium	Ø 17 - G3/8		1	
76	Washer	Aluminium	Ø 17 - G3/8		1	
85*	Kit	Flange	Zincate steel		EPE DRAWING	
	counterflange	Screw for flange	AISI 304	M16x55	UNI 5737	
	gasket	Gasket	EPDM			
92	Lip seal	Up to 3 kW	-	25x40x7	DIN 3760 without spring	
		From 4 to 7,5 kW		30x47x7		
		From 9,2 to 13 kW and 65-160/15		40x55x7		
		From 15 to 22 kW		45x60x7		
93	Lip seal	Up to 4 kW	-	25x40x7	DIN 3760 without spring	
		From 5,5 to 7,5 kW		30x47x7		
		From 9,2 to 13 kW and 65-160/15		40x55x7		
		From 15 to 22 kW		45x60x7		
101	Snap ring (only for 9.2-11-13 kW)	Carbon tool steels TC 80	Ø 40	UNI 7435	1	
200	Screw	Md xx-125	Zn. steel 8.8 strenght class ISO 898/1	M8x30	UNI 5739	
		Md xx-160		M10x35		
		Md xx-200		M12x40		
		Md xx-250		M10x40		
206	Screw	From 15kW and above (no 65-160/15)	Zn. steel 8.8 strenght class ISO 898/1	M10x40	UNI 5739	4

[1] Only for single-phase

[2] Only for three-phase

*On request