

Technical Data

Pump Name

MD 50-250/18.5

Customer	Date	2024-06-16	Company
Contact	Item no.		Issued by
Phone	Project		Phone
E-mail	Project ID	Proiect redenumit 2024-06-16 15:45:44	E-mail

Requested data

1	Pump type	CENTRIFUGAL PUMPS	Fluid	Water
2	Number of pumps / Reserve	1 / 0	Liquid temperature	°C 20
3	Flow m³/h		Kin. viscosity	mm²/s 1.005
4	Head m		Vapour pressure	bar 0.0234
5	Geodetic head m		PH value	
6	Inlet pressure (pin) bar	0	Density	kg/m³ 998.3
7	Available system NPSH		Solids	Weight % 0
8	Ambient temperature °C	20		

Pump

9	Pump Name	MD 50-250/18.5	Frequency	Hz 50
10	Design	CENTRIFUGAL PUMPS	Installation type	STANDARD
11	Manufacturer	EBARA	Impeller Diameter	Max. mm 248
12	Speed rpm	2900		Designed mm 248
13	No. of Stage	1		Min. mm 248
14	Connection Suction side	UNI 2236	Flow	Operating m³/h
15	Connection Discharge side	UNI 2236		Max- m³/h 78
16	Max Working Pressure bar	10		Min- m³/h 24
17	Shut-off head bar	8.11	Head	Operating m
18	Total weight kg	See the table of "Dimensions".		- (Qmax.) m 50.0
19	Shaft power kW			- (Qmin.) m 81.6
20			Max. Shaft Power at max. impeller	kW 19.63
21	Required pump NPSH m		Efficiency	%

Materials

22	Impeller	AISI 304	
23	Casing	Cast iron	
24	Shaft	AISI 304 (Wet extension)	
25			
26			
27			

Motor

28	Manufacturer	EPE Standard	Insulation class	F
29	Type	TEFC_MD 50-250/18.5_400_Three Phase	Phases	3~
30	Specific design	IE3 / 50 Hz / Pole pairs 1	Frame size	
31	Rated power kW	18.5	Weight	kg
32	Number of poles	2	Electric voltage	V 400
33	Speed rpm	2900	Electric current	A 35
34	Degree of protection	IP 55		
35				

Remarks

Performance Curve

Pump Name

MD 50-250/18.5

Customer	Date	2024-06-16	Company
Contact	Item no.		Issued by
Phone	Project		Phone
E-mail	Project ID	Proiect redenumit 2024-06-16 15:45:44	E-mail

Requested data

1	Flow	m³/h	
2	Head	m	
3	Geodetic head	m	

Pump

Operating flow	m³/h		Frequency	Hz	50
Operating head	m		Number of poles		2
Impeller diameter designed	mm	248	Speed	rpm	2900

Test standard: ISO 9906:2012 - Grade3B

Water; 20°C; 998.3kg/m³; 1mm²/s

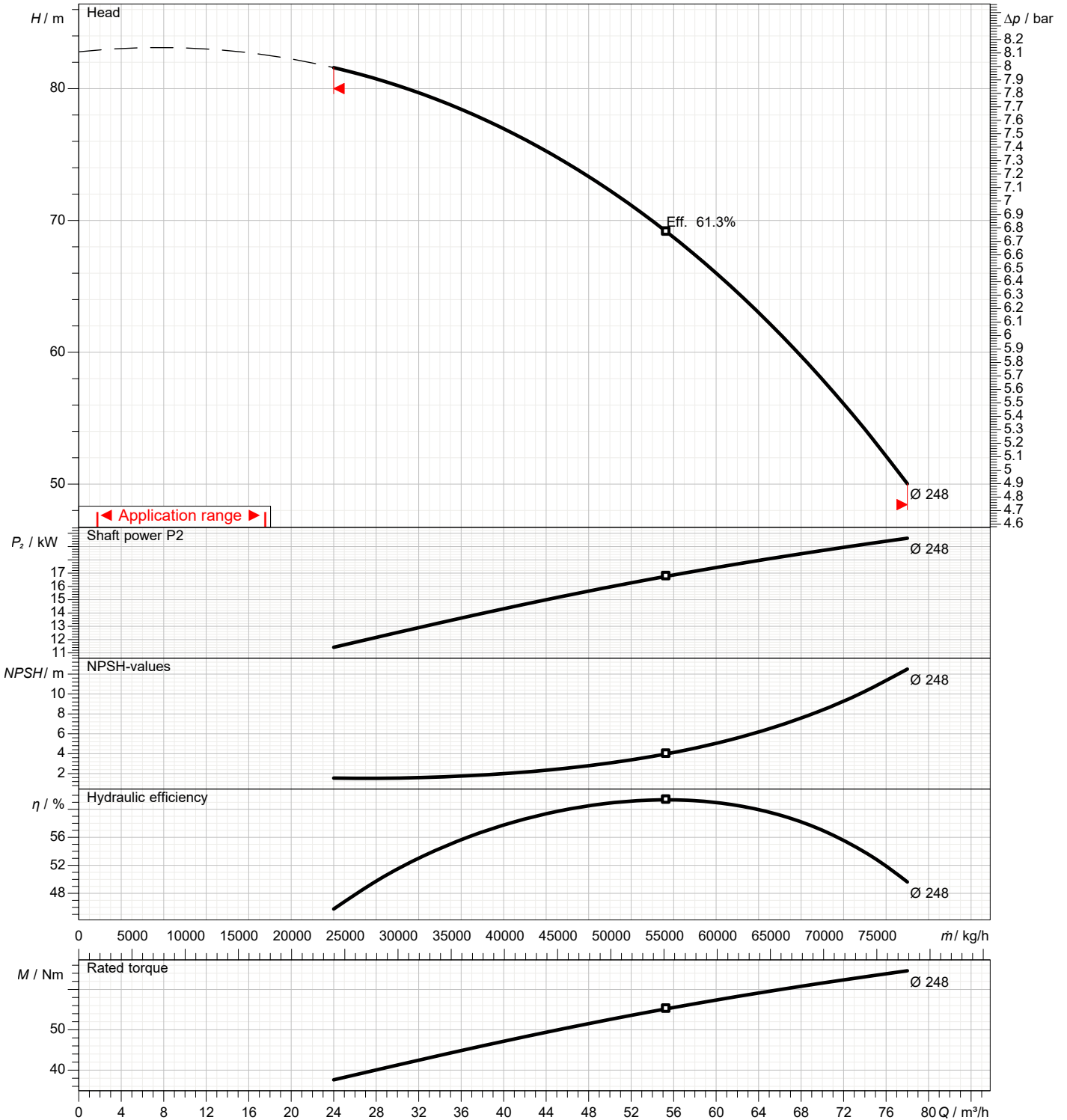

Dimensions

Pump Name MD 50-250/18.5

Customer	Date 2024-06-16	Company
Contact	Item no.	Issued by
Phone	Project	Phone
E-mail	Project ID Proiect redenumit 2024-06-16 15:45:44	E-mail

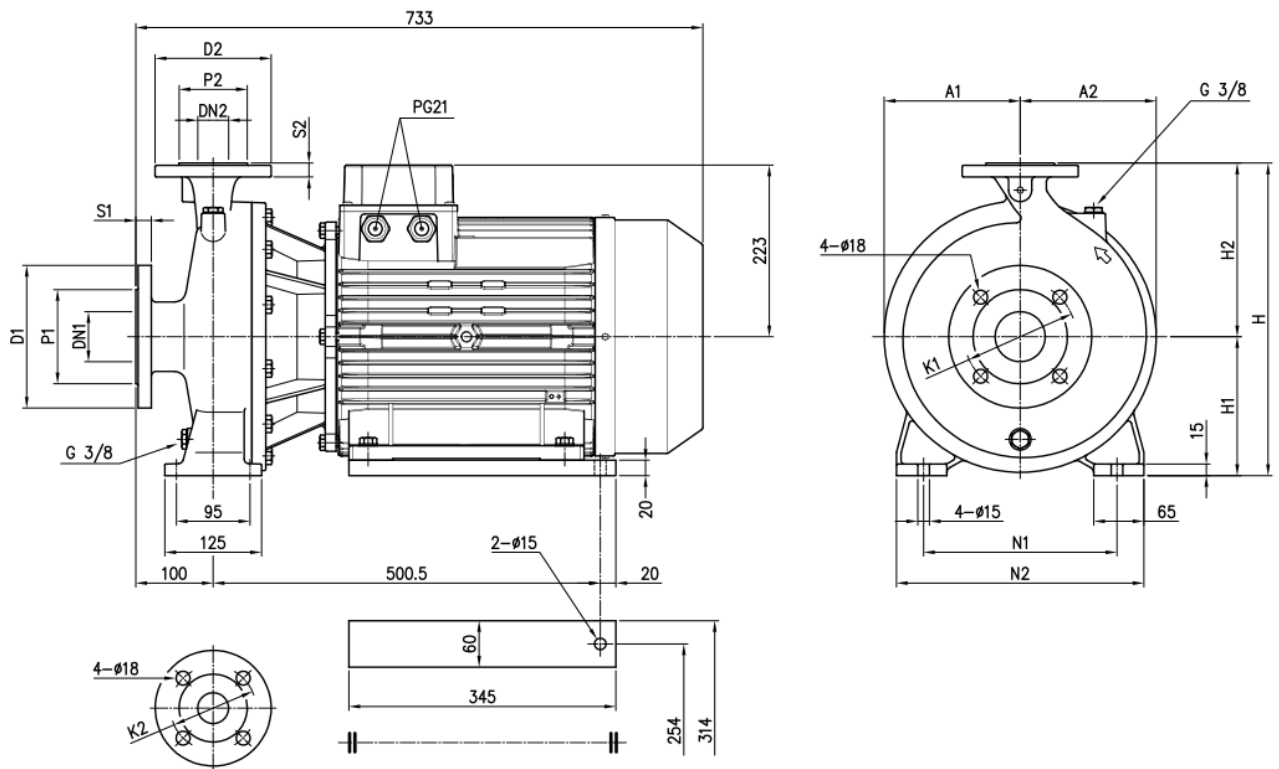

Dimensions in		mm						
1	A1	176	S1	20				
2	A2	176	S2	20				
3	D1	185	Weight P&M	136,3 kg				
4	D2	165						
5	DN1	65						
6	DN2	50						
7	H	405						
8	H1	180						
9	H2	225						
10	K1	145						
11	K2	125						
12	N1	250						
13	N2	320						
14	P1	122						
15	P2	102						

(1/3) Construction

Pump Name MD 50-250/18.5

Customer	Date 2024-06-16	Company
Contact	Item no.	Issued by
Phone	Project	Phone
E-mail	Project ID Proiect redenumit 2024-06-16 15:45:44	E-mail

UP TO 13 kW

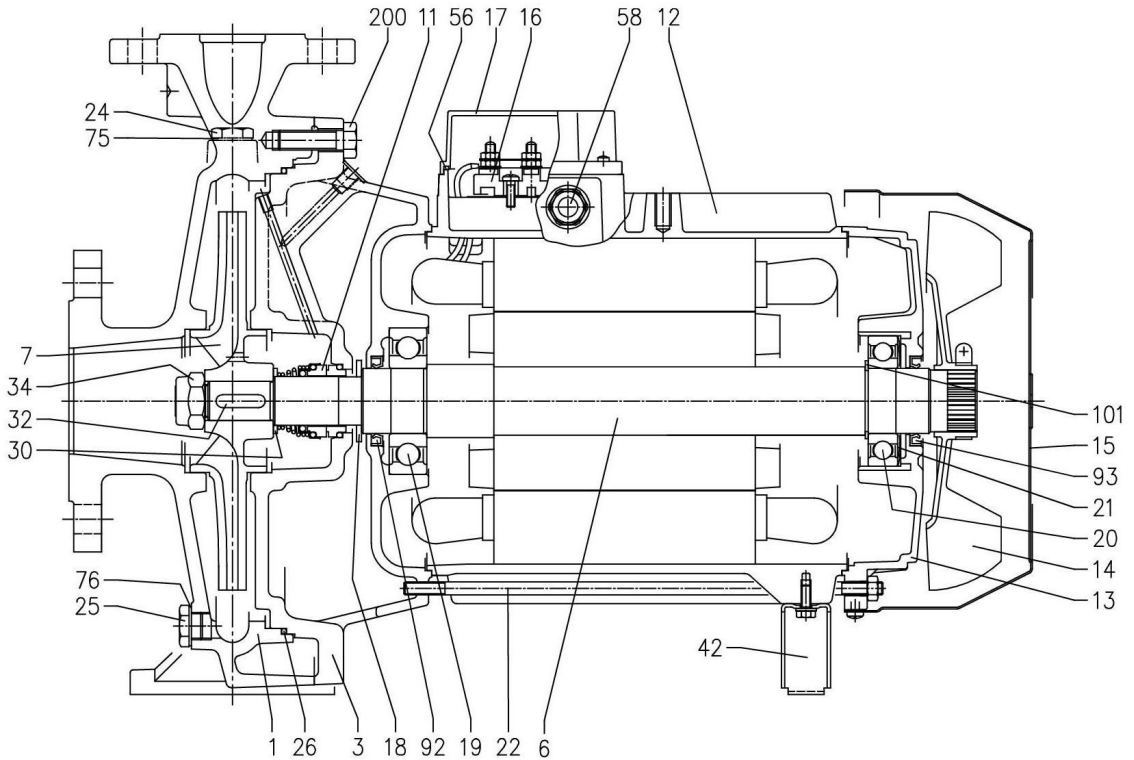

15 kW AND ABOVE (NO 65-160/15)

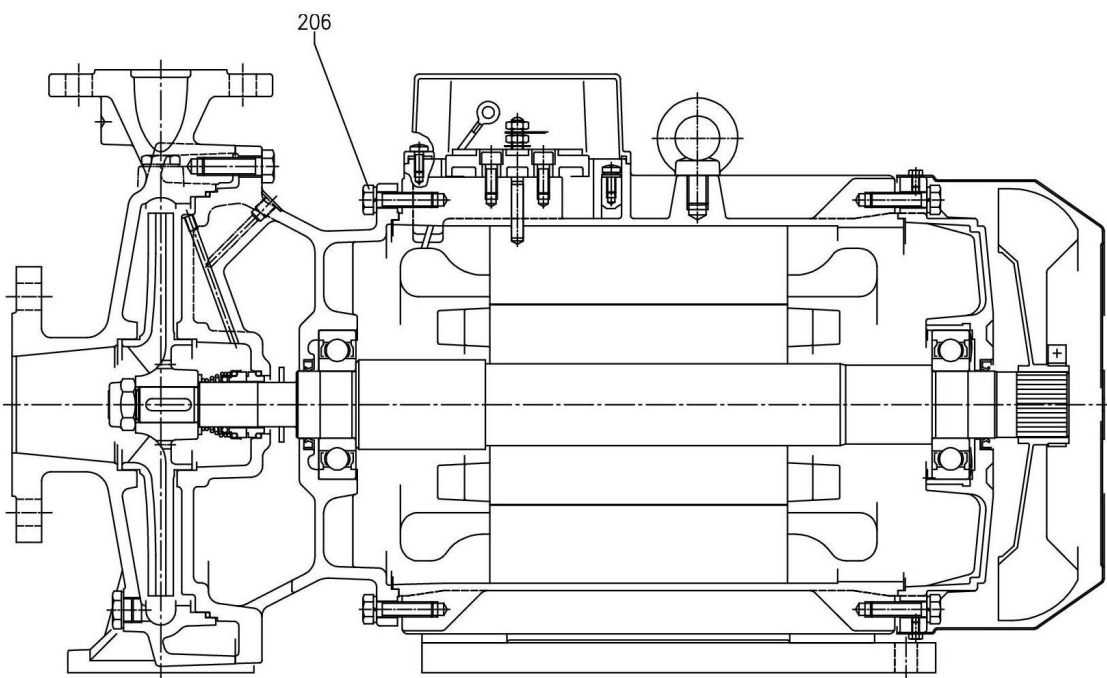

(2/3)

Construction

Pump Name MD 50-250/18.5

Customer	Date	2024-06-16	Company
Contact	Item no.		Issued by
Phone	Project		Phone
E-mail	Project ID	Project redenumit 2024-06-16 15:45:44	E-mail

N°	PART NAME	MATERIAL	DIMENSIONS	STANDARD	N. FOR UNIT	
1	Casing	Cast iron EN-GJL-200-EN 1561			1	
3	Motor bracket	Cast iron EN-GJL-200-EN 1561			1	
6	Shaft with rotor	AISI304 (Part in contact with liquid)			1	
7	Impeller	M d xx-125, M d xx-160, M d xx-200	Cast iron EN-GJL-200-EN 1561		1	
		M d xx-250	AISI304			
11	Mechanical seal	Carbon,Ceramic,NBR			1	
12	Motor frame with stator	-			1	
13	Motor cover	Aluminium			1	
14	Fan	PP			1	
15	Fan cover	Fe P04 Zincate			1	
16	Terminal box	-			1	
17	Terminal box cover	Plastic [1]-Aluminium [2]			1	
18	Splash ring	Up to 7.5 kW 9.2 kW and above	NBR	40x21.5x3	EPE DRAWING	1
				50x29.5x3		
19	Pump side ballbearing	-			1	
20	Fan side ballbearing	-			1	
21	Adjusting ring	Steel C70			1	
22	Tie rod	Up to 13 kW and MD 65-160/15	Fe 42 Zincate	EPE DRAWING	4	
	Screw	15kW and above	Zn. steel 8.8 strength class ISO 898/1	UNI5739		
24	Priming plug		Brass	EPE DRAWING	1	
25	Drain plug		Brass	EPE DRAWING	1	
26	O-ring	M d xx-125 M d xx-160 M d xx-200 M d xx-250	NBR	147x3,53	EPE DRAWING	1
				176x3,53		
				220x3,53		
				277x3,53		
30	Spacer		AISI304	22,5x26,9x2,5 (up to 7,5kW) 30,5x40x2,5 (9,2 kW and above)	EPE DRAWING	1
32	Key		AISI316	6x6x25 (up to 7,5kW)	UNI6604	1
				8x7x30 (9,2 kW and above)		
34	Impeller nut		AISI304	M 16x1,5 (up to 7,5kW) M 20x1,5 (9,2 kW and above)	UNI7474	1
42	Foot		Fe P04		EPE DRAWING	1
56	Box gasket		NBR			1
58	Cable entry [2]		-			1
75	Washer		Aluminium	Ø 17 - G 3/8		1
76	Washer		Aluminium	Ø 17 - G 3/8		1
85*	Kit counterflange	Flange	Zincate steel		EPE DRAWING	2
		Screw for flange	AISI304	M 16x55	UNI5737	8
		Gasket	EPDM			2
92	Lip seal	Up to 3 kW From 4 to 7,5 kW From 9,2 to 13 kW and 65-160/15 From 15 to 22 kW	-	25x40x7	DIN 3760 without spring	1
				30x47x7		
				40x55x7		
				45x60x7		
93	Lip seal	Up to 4 kW From 5,5 to 7,5 kW From 9,2 to 13 kW and 65-160/15 From 15 to 22 kW	-	25x40x7	DIN 3760 without spring	1
				30x47x7		
				40x55x7		
				45x60x7		
101	Snap ring (only for 9,2-11-13 kW)		Carbon tool steel TC 80	Ø 40	UNI7435	1
200	Screw	M d xx-125 M d xx-160 M d xx-200 M d xx-250	Zn. steel 8.8 strength class ISO 898/1	M 8x30	UNI5739	8
				M 10x35		10
				M 12x40		12
				M 10x40		12
206	Screw	From 15kW and above (no 65-160/15)	Zn. steel 8.8 strength class ISO 898/1	M 10x40	UNI5739	4

[1] Only for single-phase

[2] Only for three-phase

*On request

(3/3)

Construction

Pump Name MD 50-250/18.5

Customer	Date 2024-06-16	Company
Contact	Item no.	Issued by
Phone	Project	Phone
E-mail	Project ID Proiect redenumit 2024-06-16 15:45:44	E-mail

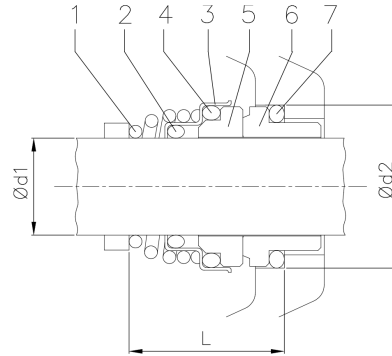

Pump type	Dimensions mm		
	Ø d1	Ø d2	L
MD 32-250/5.5	22	37	37,5
MD 32-250/7.5			
MD 32-250/9.2	30	45	42,5
MD 32-250/11			
MD 40-250/11	30	45	42,5
MD 40-250/15			
MD 50-250/15	30	45	42,5
MD 50-250/18,5			
MD 50-250/22			

REF	PART NAME	MATERIAL Standard version (MD)
1	Self driving spring	AISI 316
2	O Ring	NBR
3	Frame	AISI 304
4	O Ring	NBR
5	Rotary seal ring	Ceramic
6	Stationary seal ring	Carbon graphite
7	O Ring	NBR