

Technical Data

Pump Name

MMD4 200-250/18.5 QQPFF

Customer	Date	2024-06-16	Company
Contact	Item no.		Issued by
Phone	Project		Phone
E-mail	Project ID	Proiect redenumit 2024-06-16 15:45:44	E-mail

Requested data

1	Pump type	CENTRIFUGAL PUMPS	Fluid	Water
2	Number of pumps / Reserve	1 / 0	Liquid temperature	°C 20
3	Flow m³/h		Kin. viscosity	mm²/s 1.005
4	Head m		Vapour pressure	bar 0.0234
5	Geodetic head m		PH value	
6	Inlet pressure (pin) bar	0	Density	kg/m³ 998.3
7	Available system NPSH		Solids	Weight % 0
8	Ambient temperature °C	20		

Pump

9	Pump Name	MMD4 200-250/18.5 QQPFF	Frequency	Hz	50
10	Design	CENTRIFUGAL PUMPS	Installation type		STANDARD
11	Manufacturer	EBARA	Impeller Diameter	Max.	mm 210
12	Speed rpm	1450		Designed	mm 210
13	No. of Stage	1		Min.	mm 210
14	Connection Suction side		Flow	Operating	m³/h
15	Connection Discharge side			Max-	m³/h 500
16	Max Working Pressure bar	10		Min-	m³/h 115
17	Shut-off head bar	1.66	Head	Operating	m
18	Total weight kg	See the table of "Dimensions".		- (Qmax.)	m 9.4
19	Shaft power kW			- (Qmin.)	m 16.5
20			Max. Shaft Power at max. impeller	kW	17.34
21	Required pump NPSH m		Efficiency	%	

Materials

22	Impeller	EN-GJL-200		
23	Intermediate casing	EN-GJL-200		
24	Bottom casing	EN-GJL-200		
25	Shaft	Stainless steel		
26	Gasket	AF1600		
27				

Motor

28	Manufacturer	ABLE	Insulation class	F
29	Type	TEFC_MMD4 200-250/18.5_400_Three Phase	Phases	3~
30	Specific design	IE3 / 50 Hz / Pole pairs 2	Frame size	180
31	Rated power kW	18.5	Weight	kg 160
32	Number of poles	4	Electric voltage	V 400
33	Speed rpm	1468	Electric current	A 36.4
34	Degree of protection	IP 55		
35				

Remarks

--

Performance Curve

Pump Name

MMD4 200-250/18.5 QQPFF

Customer	Date	2024-06-16	Company
Contact	Item no.		Issued by
Phone	Project		Phone
E-mail	Project ID	Project redenumit 2024-06-16 15:45:44	E-mail

Requested data

1	Flow	m³/h	
2	Head	m	
3	Geodetic head	m	

Pump

Operating flow	m³/h		Frequency	Hz	50
Operating head	m		Number of poles		4
Impeller diameter designed	mm	210	Speed	rpm	1450

Test standard: ISO 9906:2012 - Grade3B

Water; 20°C; 998.3kg/m³; 1mm²/s

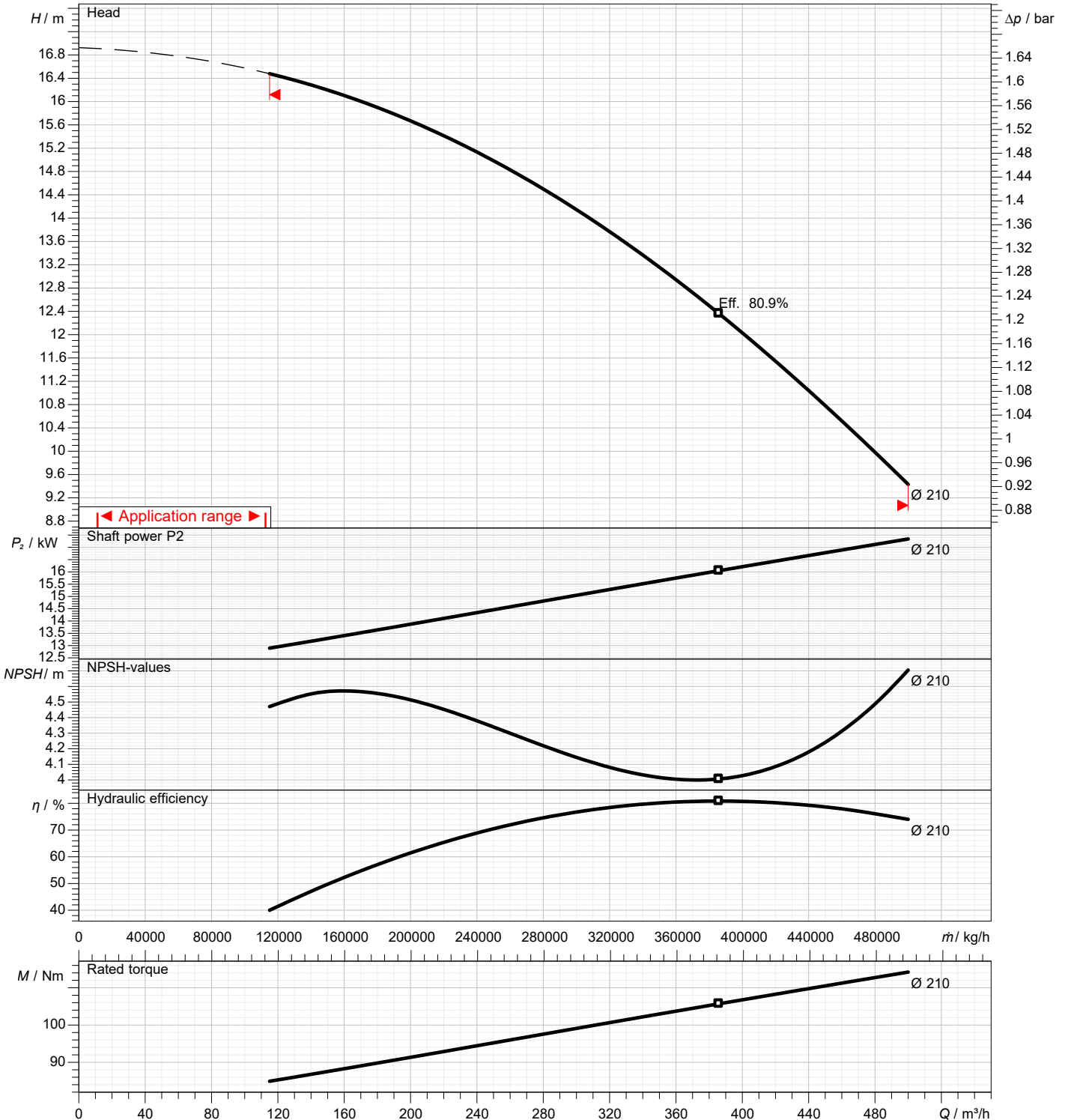

(1/2)

Construction

Pump name MMD4 200-250/18.5 QQPFF

Customer	Date 2024-06-16	Company
Contact	Item no.	Issued by
Phone	Project	Phone
E-mail	Project ID Proiect redenumit 2024-06-16 15:45:44	E-mail

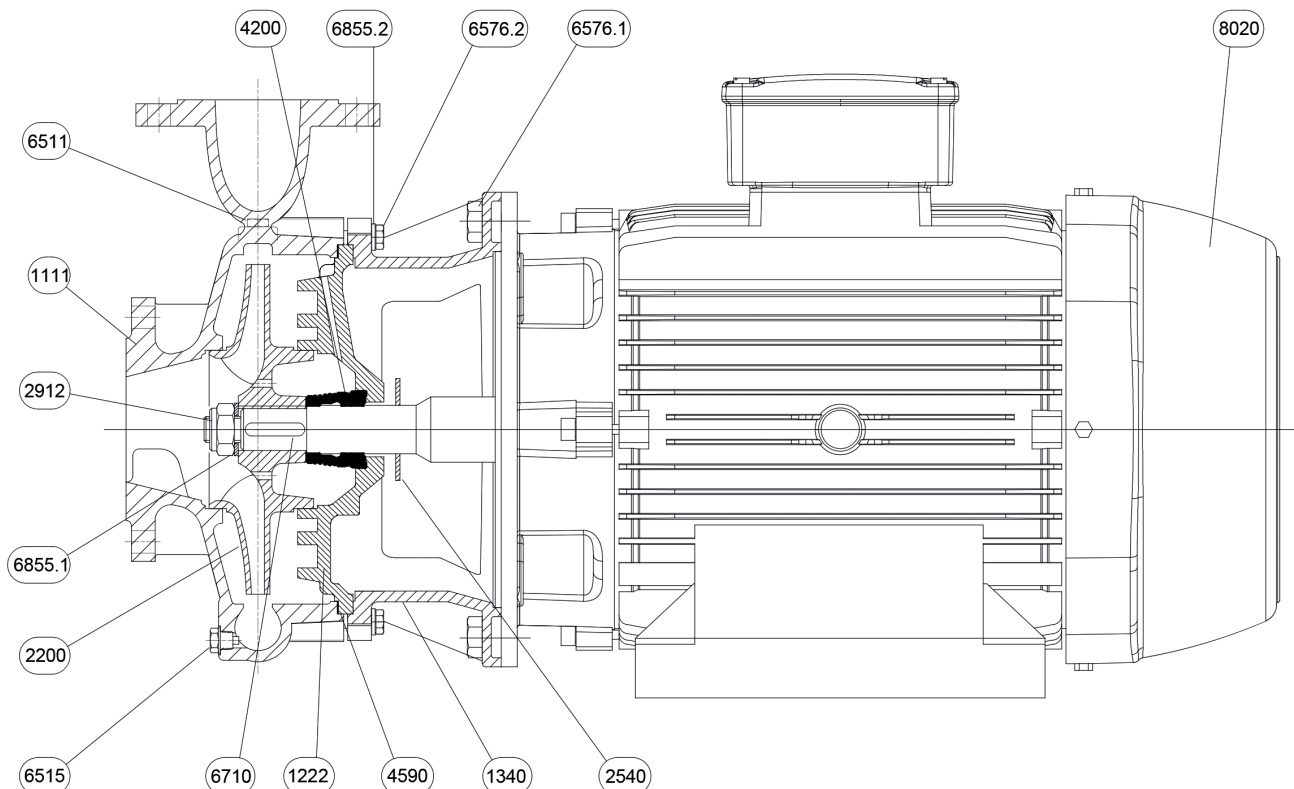

N°	PART NAME	MATERIAL	Q.TY
1111	Pump casing	EN-GJL-200	1
1222	Gland cover	EN-GJL-200	1
1340	Lantern	EN-GJL-200	1
2200	Impeller nut	EN-GJL-200	1
2540	Baffle	NB 70	1
2912	Impeller nut	6.8-ZN	1
4200	Mechanical seal	Sic/Sic/NBR/AISI 304	1
4590	Gasket	AF1600	1
6511	Refil plug	EN-GJMB-350-10	1
6515	Drain plug	EN-GJMB-350-10	1
6576.1	Hexagonal head screw	8.8-ZN	4
6576.2	Hexagonal head screw	8.8-ZN	8
6710	Key	C50	1
6855.1	Impeller washer	R40-ZN	1
6855.2	Washer	R40-ZN	8
8020	Motor		1

(2/2)

Construction

Pump name MMD4 200-250/18.5 QQPFF

Customer	Date 2024-06-16	Company
Contact	Item no.	Issued by
Phone	Project	Phone
E-mail	Project ID Proiect redenumit 2024-06-16 15:45:44	E-mail

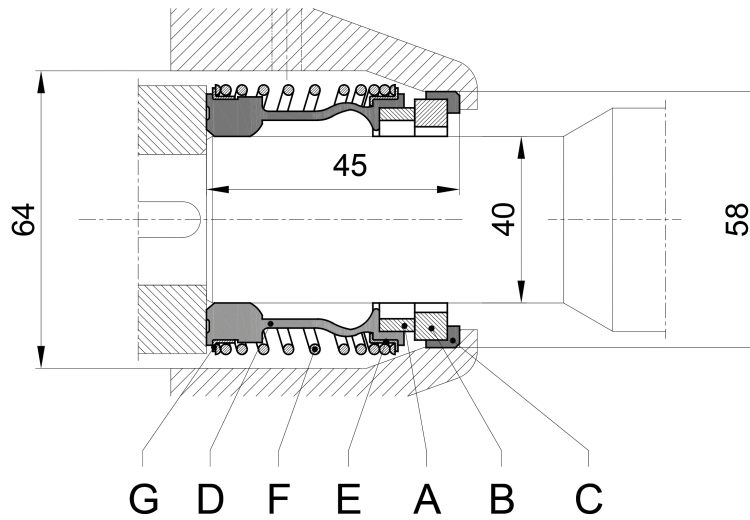

Ref.	Name	Material
A	Rotary seal ring	Carbon
B	Stationary seal ring	Silicon Carbide
C	Gasket	EPDM
D	Bellows	EPDM
E	Spring plate	AISI 304
F	Spring	AISI 304
G	Spring plate	AISI 304