

# Technical Data

Pump Name

MMD4 50-200/1.1 QQPFF

Customer	Date	2024-06-16	Company
Contact	Item no.		Issued by
Phone	Project		Phone
E-mail	Project ID	Proiect redenumit 2024-06-16 15:45:44	E-mail

## Requested data

1	Pump type	CENTRIFUGAL PUMPS	Fluid	Water
2	Number of pumps / Reserve	1 / 0	Liquid temperature	°C
3	Flow	m³/h	Kin. viscosity	mm²/s
4	Head	m	Vapour pressure	bar
5	Geodetic head	m	PH value	
6	Inlet pressure (pin)	bar	Density	kg/m³
7	Available system NPSH		Solids	Weight %
8	Ambient temperature	°C		

## Pump

9	Pump Name	MMD4 50-200/1.1 QQPFF	Frequency	Hz	50	
10	Design	CENTRIFUGAL PUMPS	Installation type		STANDARD	
11	Manufacturer	EBARA	Impeller Diameter	Max.	mm	
12	Speed	rpm		1450	Designed	mm
13	No. of Stage			1	Min.	mm
14	Connection	Suction side	Flow	Operating	m³/h	
15	Connection	Discharge side		Max-	m³/h	36
16	Max Working Pressure	bar		10	Min-	m³/h
17	Shut-off head	bar	1.23	Head	Operating	m
18	Total weight	kg	See the table of "Dimensions".		- (Qmax.)	m
19	Shaft power	kW			- (Qmin.)	m
20			Max. Shaft Power at max. impeller	kW	1.09	
21	Required pump NPSH	m	Efficiency	%		

## Materials

22	Impeller	EN-GJL-200		
23	Intermediate casing	EN-GJL-200		
24	Bottom casing	EN-GJL-200		
25	Shaft	Stainless steel		
26	Gasket	AF1600		
27				

## Motor

28	Manufacturer	ICME	Insulation class	F	
29	Type	TEFC_MMD4// 50-200/1.1_230_Three Phase	Phases	3~	
30	Specific design	IE3 / 50 Hz / Pole pairs 2	Frame size	90	
31	Rated power	kW	1.1	Weight	kg
32	Number of poles	4	Electric voltage	V	230
33	Speed	rpm	1420	Electric current	A
34	Degree of protection	IP 55			
35					

## Remarks

# Performance Curve

Pump Name

MMD4 50-200/1.1 QQPFF

Customer	Date	2024-06-16	Company
Contact	Item no.		Issued by
Phone	Project		Phone
E-mail	Project ID	Project redenumit 2024-06-16 15:45:44	E-mail

## Requested data

1	Flow	m³/h	
2	Head	m	
3	Geodetic head	m	

## Pump

Operating flow	m³/h		Frequency	Hz	50
Operating head	m		Number of poles		4
Impeller diameter designed	mm	200	Speed	rpm	1450

Test standard: ISO 9906:2012 - Grade3B

Water; 20°C; 998.3kg/m³; 1mm²/s

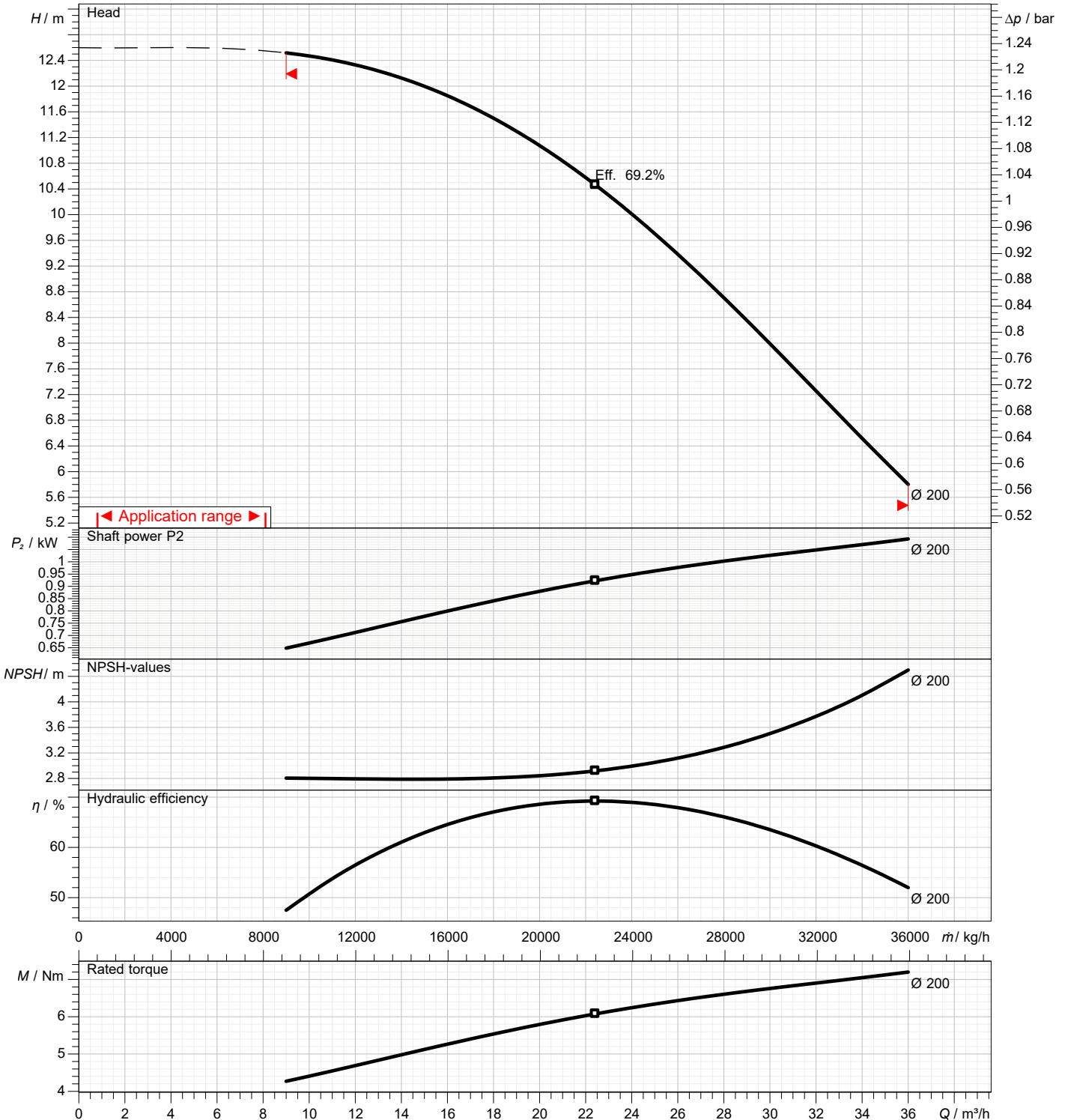

# Dimensions

Pump name MMD4 50-200/1.1 QQPFF

Customer	Date 2024-06-16	Company
Contact	Item no.	Issued by
Phone	Project	Phone
E-mail	Project ID Proiect redenumit 2024-06-16 15:45:44	E-mail

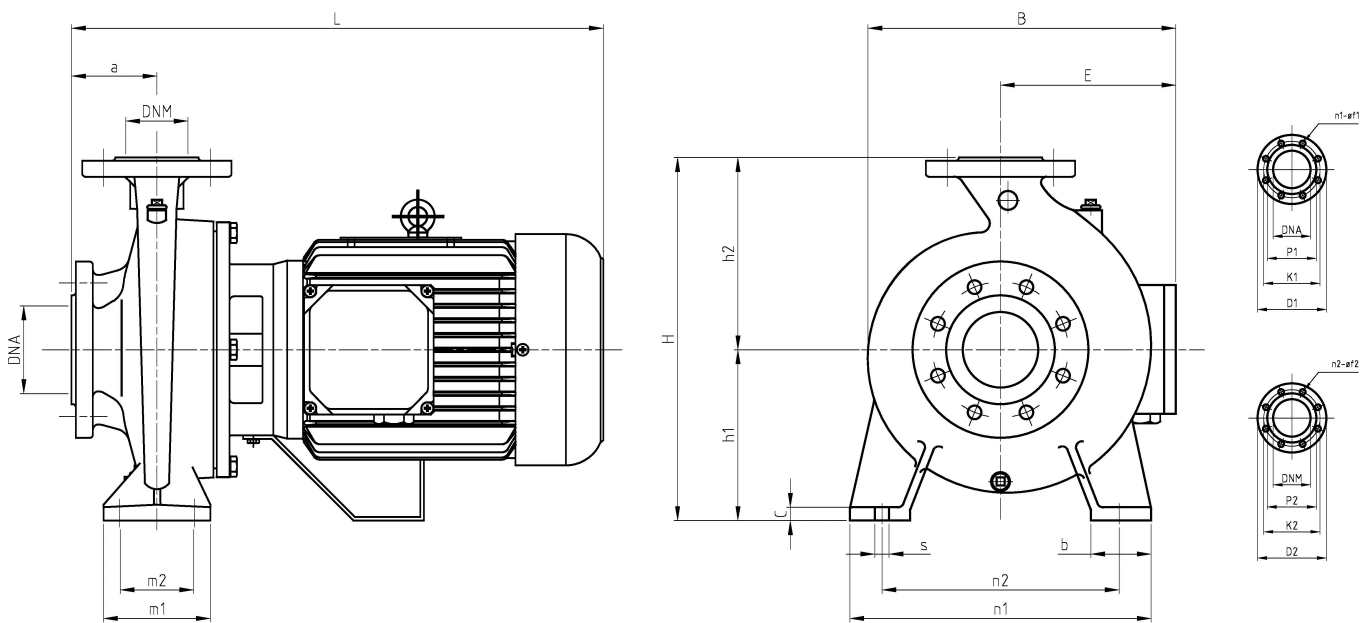

Dimensions in		mm	
1	a	100	Dia P2 102
2	b	50	E 138
3	B	285	H 360
4	C	12	h1 160
5	Dia D1	185	h2 200
6	Dia D2	165	L 476
7	Dia DNA	65	m1 100
8	Dia DNM	50	m2 70
9	Dia f1	18	n1 265
10	Dia f2	18	n2 215
11	Dia K1	145	s 14
12	Dia K2	125	Weight P&M [41].6 kg
13	Dia n1	4	
14	Dia n2	4	
15	Dia P1	122	

(1/2)

# Construction

Pump name MMD4 50-200/1.1 QQPFF

Customer	Date 2024-06-16	Company
Contact	Item no.	Issued by
Phone	Project	Phone
E-mail	Project ID Proiect redenumit 2024-06-16 15:45:44	E-mail

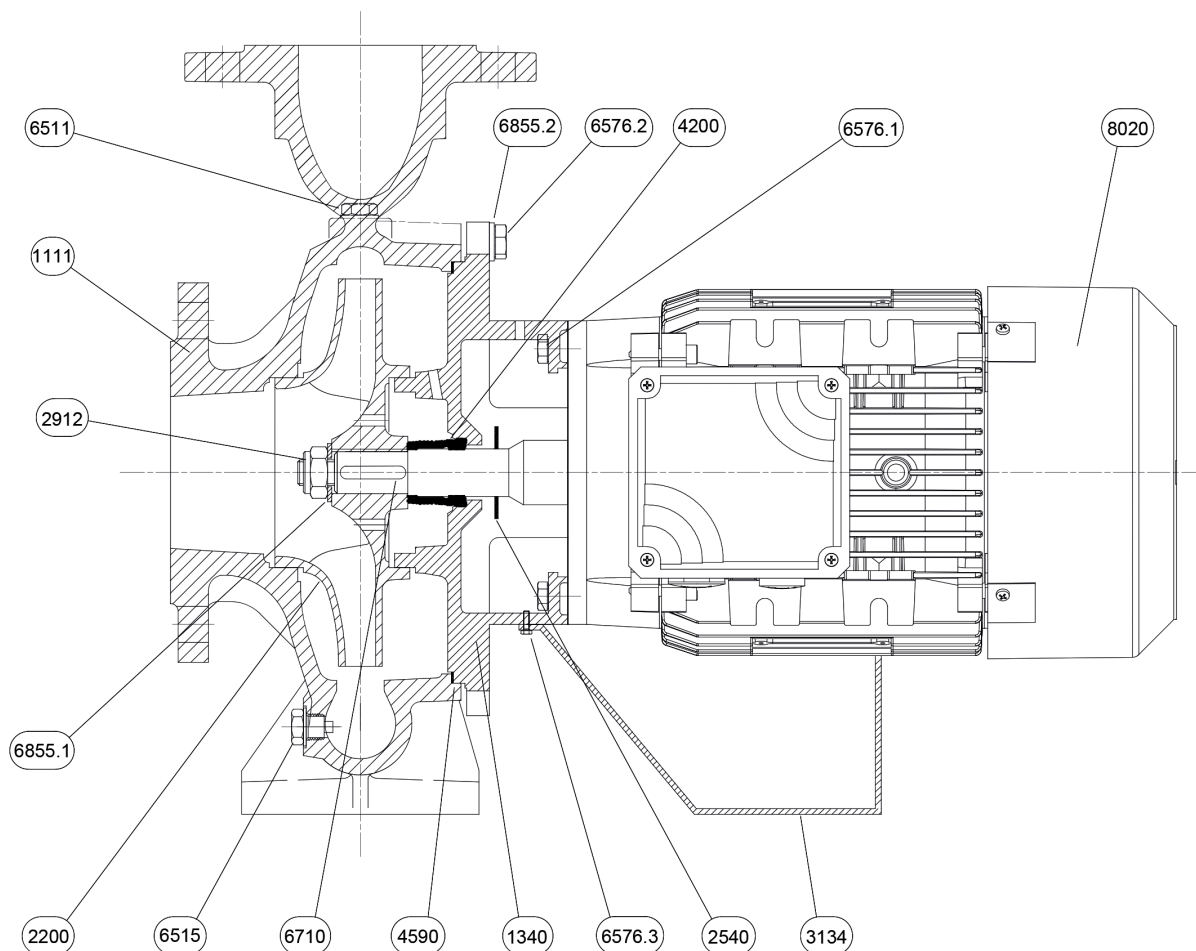

N°	PART NAME	MATERIAL	Q.TY
1111	Pump casing	EN-GJL-200	1
1340	Latern-Cover	EN-GJL-200	1
2200	Impeller	EN-GJL-200	1
2540	Baffle	NB 70	1
2912	Impeller nut	6.8-ZN	1
3134	Support foot	S235JR	1
4200	Mechanical seal	Sic/Sic/NBR/AISI 304	1
4590	Gasket	AF 1600	1
6511	Refil plug	EN GJMB-350-10	1
6515	Drain plug	EN GJMB-350-10	1
6576.1	Hexagonal head screw	8.8-ZN	4
6576.2	Hexagonal head screw	8.8-ZN	8
6576.3	Hexagonal head screw	8.8-ZN	1
6710	Key	C50	1
6855.1	Impeller washer	R40-ZN	1
6855.2	Washer	R40-ZN	8
8020	Motor		1

(2/2)

# Construction

Pump name MMD4 50-200/1.1 QQPFF

Customer	Date 2024-06-16	Company
Contact	Item no.	Issued by
Phone	Project	Phone
E-mail	Project ID Proiect redenumit 2024-06-16 15:45:44	E-mail



Ref.	Name	Material
A	Rotary seal ring	Carbon
B	Stationary seal ring	Silicon Carbide
C	Gasket	EPDM
D	Bellows	EPDM
E	Spring plate	AISI 304
F	Spring	AISI 304
G	Spring plate	AISI 304