

Technical data

Pump name OY6BHE 48-9/15

Customer	Date 2024-06-13	Company
Contact	Item no.	Issued by
Phone	Project	Phone
E-mail	Project ID Proiect redenumit 2024-06-13 07:43:07	E-mail

Requested data

1	Pump type	SUBMERSIBLE DEEPWELL PUMPS	Fluid	Water
2	Number of pumps / Reserve	1 / 0	Liquid temperature	°C 20
3	Flow	m³/h	Kin. viscosity	mm²/s 1.005
4	Head	m	Vapour pressure	bar 0.0234
5	Geodetic head	m	PH value	
6	Inlet pressure (pin)	bar 0	Density	kg/m³ 998.3
7	Available system NPSH		Solids	Weight % 0
8	Ambient temperature	°C 20		

Pump

9	Pump name	OY6BHE 48-9/15	Frequency	Hz 50
10	Design	SUBMERSIBLE DEEPWELL PUMPS	Installation type	Ebara Motor Oil 6"
11	Manufacturer	EBARA	Impeller Diameter	Max. mm 0
12	Speed	rpm 2850		Designed mm
13	No. of Stage	9		Min. mm 0
14	Connection Suction side		Flow	Operating m³/h
15	Connection Discharge side	Rp 3"		Max- m³/h 60
16	Max Working Pressure	bar 70		Min- m³/h 25
17	Shut-off head	bar 11.89	Head	Operating m
18	Total weight	kg See the table of "Dimensions".		- (Qmax.) m 54.4
19	Shaft power	kW		- (Qmin.) m 105.8
20	Max. fluid temperature	°C 40	Max. Shaft Power at max. impeller	kW 11.87
21	Required pump NPSH	m	Efficiency	%

Materials

22	Impeller	EN 1.4301 (AISI 304)		
23	Discharge casing	EN 1.4301 (AISI 304)		
24	Shaft	EN 1.4057 (AISI 431)		
25	Diffuser	EN 1.4301 (AISI 304)		
26				
27				

Motor

28	Manufacturer	EBARA MOTOR	Insulation class	IP 58
29	Type	6" 6BHE 48-9/15_380_Three Phase	Phases	3~
30	Specific design	Submersible oil filled type / 50 Hz / Pole pairs 1	Frame size	6"
31	Rated power	kW 15	Weight	kg 54
32	Number of poles	2	Electric voltage	V 380
33	Speed	rpm 2830	Electric current	A 31.4
34	Degree of protection	F		
35				

Remarks

Performance Curve

Pump Name

OY6BHE 48-9/15

Customer	Date	2024-06-13	Company
Contact	Item no.		Issued by
Phone	Project		Phone
E-mail	Project ID	Proiect redenumit 2024-06-13 07:43:07	E-mail

Requested data

1	Flow	m³/h	
2	Head	m	
3	Geodetic head	m	

Pump

Operating flow	m³/h	Frequency	Hz	50
Operating head	m	Number of poles		2
Impeller diameter designed	mm	Speed	rpm	2850

Test standard: ISO 9906:2012 - Grade3B

Water; 20°C; 998.3kg/m³; 1mm²/s

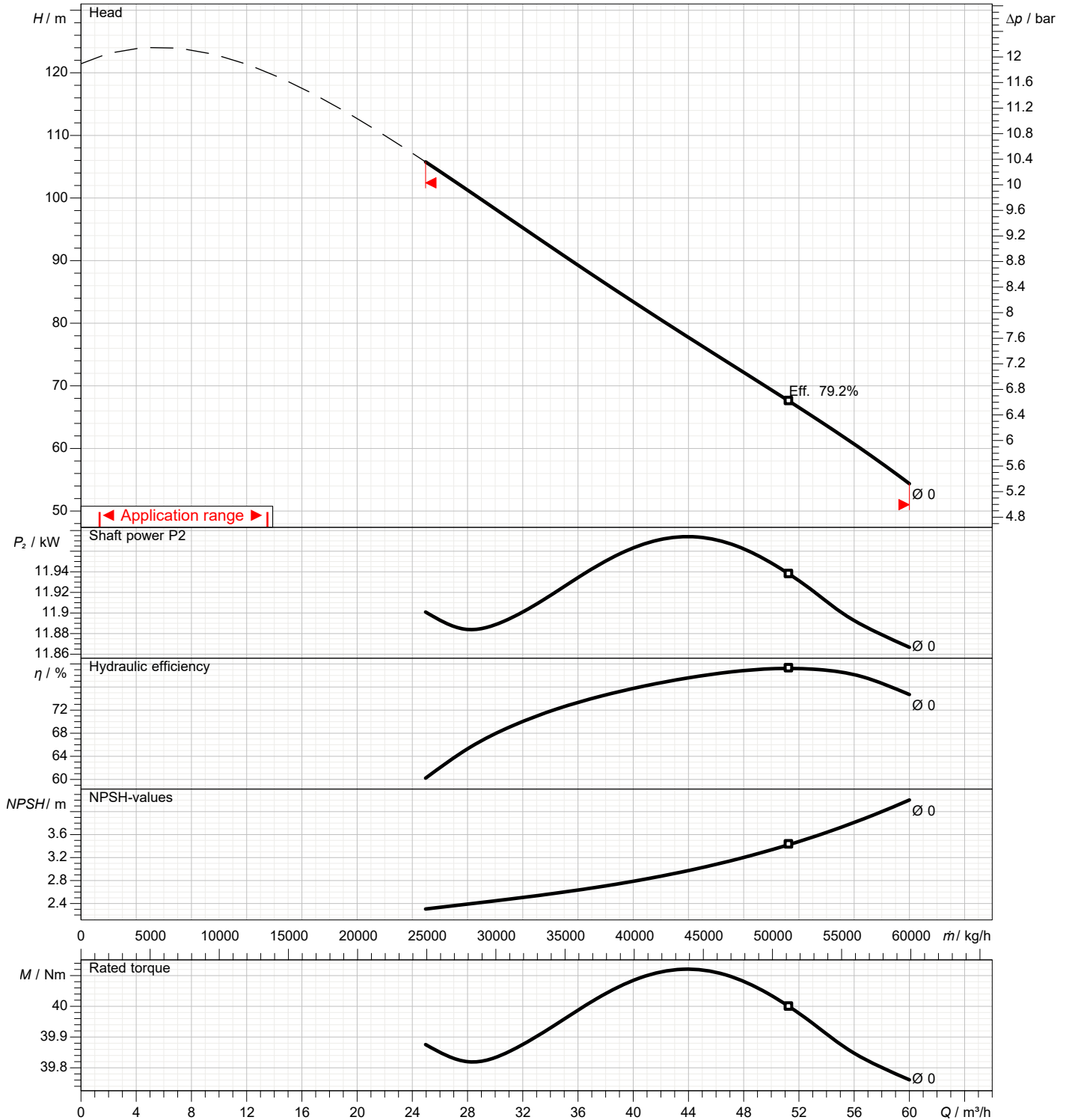

Dimensions

Pump name OY6BHE 48-9/15

Customer	Date 2024-06-13	Company
Contact	Item no.	Issued by
Phone	Project	Phone
E-mail	Project ID Proiect redenumit 2024-06-13 07:43:07	E-mail

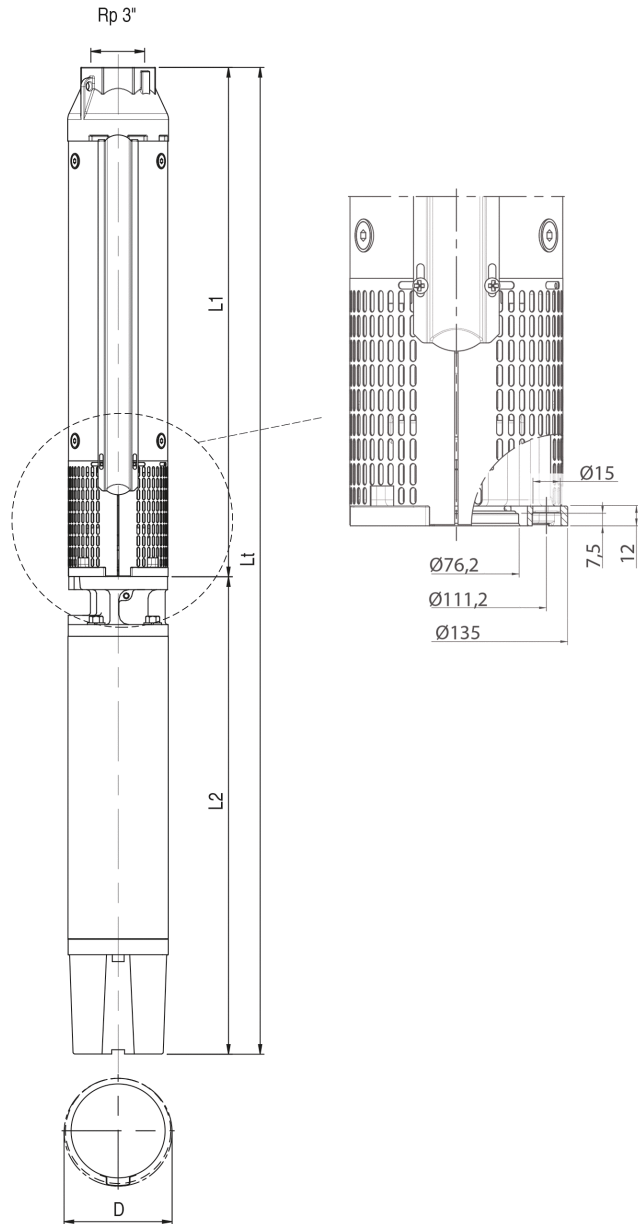

Dimensions in		mm						
1	D 1 CABLE	143						
2	D 2 CABLE	144.5						
3	L1	1389						
4	L2	760						
5	Lt	2149						
6	Weight P&M	142,5 kg						
7								
8								
9								
10								
11								
12								
13								
14								
15								

(1/2)

Construction

Pump name OY6BHE 48-9/15

Customer	Date 2024-06-13	Company
Contact	Item no.	Issued by
Phone	Project	Phone
E-mail	Project ID Proiect redenumit 2024-06-13 07:43:07	E-mail

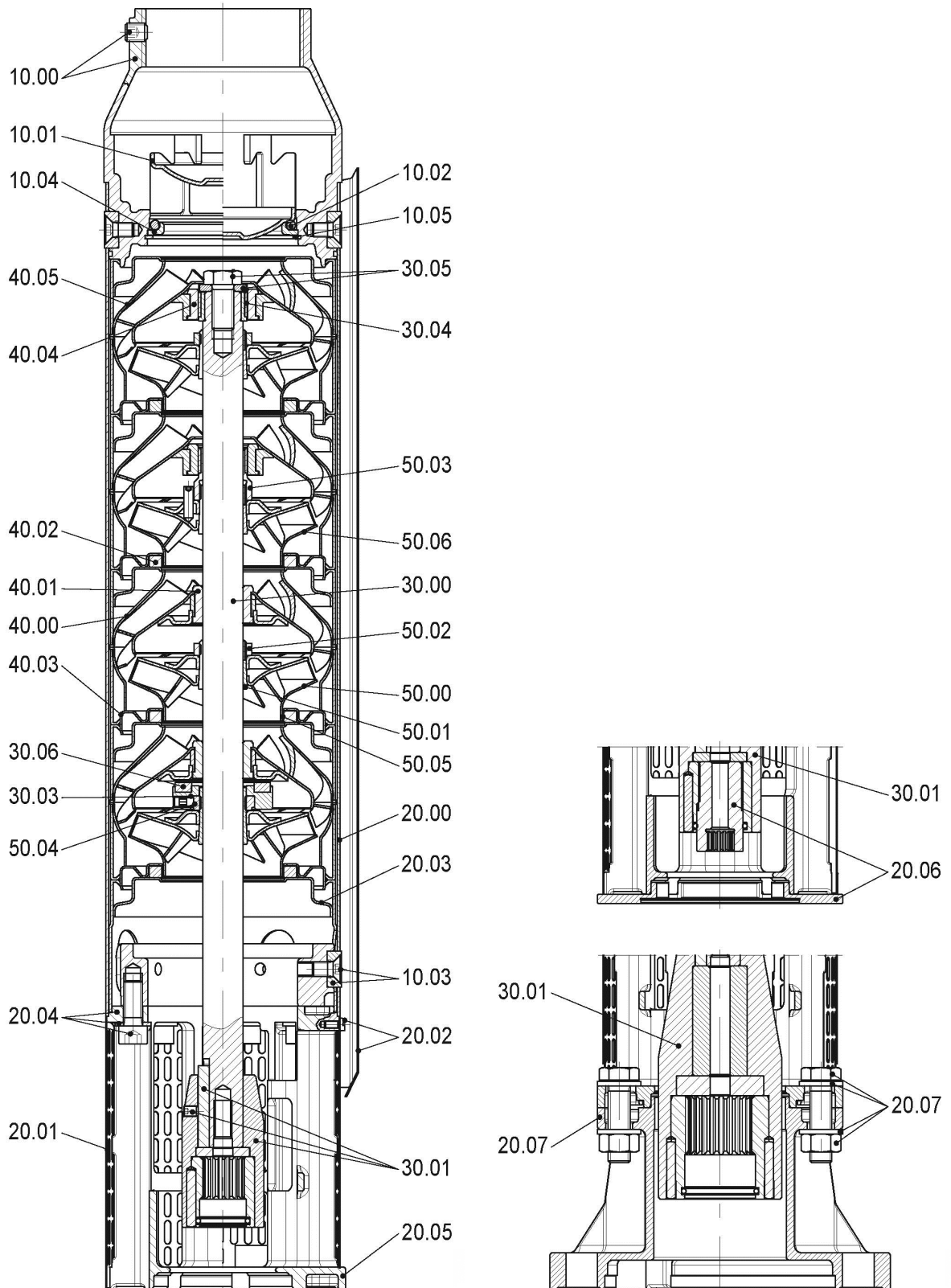

(2/2)

Construction

Pump name OY6BHE 48-9/15

Customer	Date	2024-06-13	Company
Contact	Item no.		Issued by
Phone	Project		Phone
E-mail	Project ID	Proiect redenumit 2024-06-13 07:43:07	E-mail

N°	NAME	MATERIAL Standard version
10.00	Discharge head and screw	EN 1.4301 (AISI 304)
10.01	Valve	EN 1.4401 (AISI 316)
10.02	O-ring	NBR
10.03	Screws and outer case locking nuts	EN 1.4401 (AISI 316)
10.04	Valve support	EN 1.4401 (AISI 316)
10.05	Seeger ring	EN 1.4401 (AISI 316)
20.00	Outer case	EN 1.4301 (AISI 304)
20.01	Suction strainer	EN 1.4401 (AISI 316)
20.02	Cable guard and screws	EN 1.4401 (AISI 316)
20.03	Initial spacer	EN 1.4301 (AISI 304)
20.04	Flange and bolts	EN 1.4301 (AISI 304)
20.05	Motor adapter	EN 1.4301 (AISI 304)
30.00	Pump shaft	EN 1.4057 (AISI 431)
30.01	Coupling	EN 1.4057 (AISI 431) + EN 1.4460 (AISI 329)
30.03	Lower up-thrust washer	EN 1.4401 (AISI 316)
30.04	Upper journal sleeve	EN 1.4460 (AISI 329) with ceramic coating
30.05	Screw and washer	EN 1.4401 (AISI 316)
30.06	Up-thrust ring	PTFE + Graphite
40.00	Diffusers	EN 1.4301 (AISI 304)
40.01	Secondary bearing bush	NBR
40.02	Floating neck ring	PTFE
40.03	Flange clamping neck ring	EN 1.4301 (AISI 304)
40.04	Bearing bush	NBR
40.05	Last / intermediate diffuser	EN 1.4401 (AISI 316)
50.00	Impeller	EN 1.4301 (AISI 304)
50.01	Split cone	EN 1.4401 (AISI 316)
50.02	Split cone nut	EN 1.4401 (AISI 316)
50.03	Intermediate split cone nut	EN 1.4401 (AISI 316)
50.04	Up-thrust split cone nut	EN 1.4401 (AISI 316)
50.05	Wear ring	EN 1.4301 (AISI 304)
50.06	Intermediate impeller with screw	EN 1.4301 (AISI 304)