

Technical data

Pump name SWS 50 M

Customer	Date	2024-06-16	Company
Contact	Item no.		Issued by
Phone	Project		Phone
E-mail	Project ID	Proiect redenumit 2024-06-16 15:45:44	E-mail

Requested data

1	Pump type	CENTRIFUGAL PUMPS FOR POOLS	Fluid	Water
2	Number of pumps / Reserve	1 / 0	Liquid temperature	°C 20
3	Flow	m³/h	Kin. viscosity	mm²/s 1.005
4	Head	m	Vapour pressure	bar 0.0234
5	Geodetic head	m	PH value	
6	Inlet pressure (pin)	bar 0	Density	kg/m³ 998.3
7	Available system NPSH		Solids	Weight % 0
8	Ambient temperature	°C 20		

Pump

9	Pump name	SWS 50 M	Frequency	Hz 50
10	Design	CENTRIFUGAL PUMPS FOR POOLS	Installation type	STANDARD
11	Manufacturer	EBARA	Impeller Diameter	Max. mm 0
12	Speed	rpm 2900		Designed mm
13	No. of Stage	1		Min. mm 0
14	Connection Suction side	Female thread 1" 1/2 (Kit PV50 included)	Flow	Operating m³/h
15	Connection Discharge side	Female thread 1" 1/2 (Kit PV50 included)		Max- m³/h 15
16	Max Working Pressure	bar		Min- m³/h 0.96
17	Shut-off head	bar 1.19	Head	Operating m
18	Total weight	kg See the table of "Dimensions".		- (Qmax.) m 1.7
19	Shaft power	kW		- (Qmin.) m 12.2
20	Max. fluid temperature	°C 40	Max. Shaft Power at max. impeller	kW 0.48
21	Required pump NPSH	m	Efficiency	%

Materials

22	Pump body	Polypropylene reinforced with glass fibre	
23	Pump Body Lid	Polypropylene reinforced with glass fibre	
24	Diffuser	Polypropylene reinforced with glass fibre	
25	Impeller	Noryl	
26	Mechanicals seal	Carbon / Ceramic / Stainless Steel AISI 316	
27	Shaft	Stainless Steel AISI 316	

Motor

28	Manufacturer	EPE Standard	Insulation class	F
29	Type	SWS 50 M_230_Single Phase	Phases	1~
30	Specific design	- / 50 Hz / Pole pairs 1	Frame size	
31	Rated power	kW 0.33	Weight	kg
32	Number of poles	2	Electric voltage	V 230
33	Speed	rpm 2900	Electric current	A 3.5
34	Degree of protection	IP 55		
35				

Remarks

Performance curve

Pump name **SWS 50 M**

Customer	Date	2024-06-16	Company
Contact	Item no.		Issued by
Phone	Project		Phone
E-mail	Project ID	Project redenumit 2024-06-16 15:45:44	E-mail

Requested data

1	Flow	m ³ /h	
2	Head	m	
3	Geodetic head	m	

Pump

Operating flow	m ³ /h		Impeller Diameter Designed	mm	
Operating head	m		Frequency	Hz	50
			Speed	rpm	2900

Water; 20°C; 998.3kg/m³; 1mm²/s

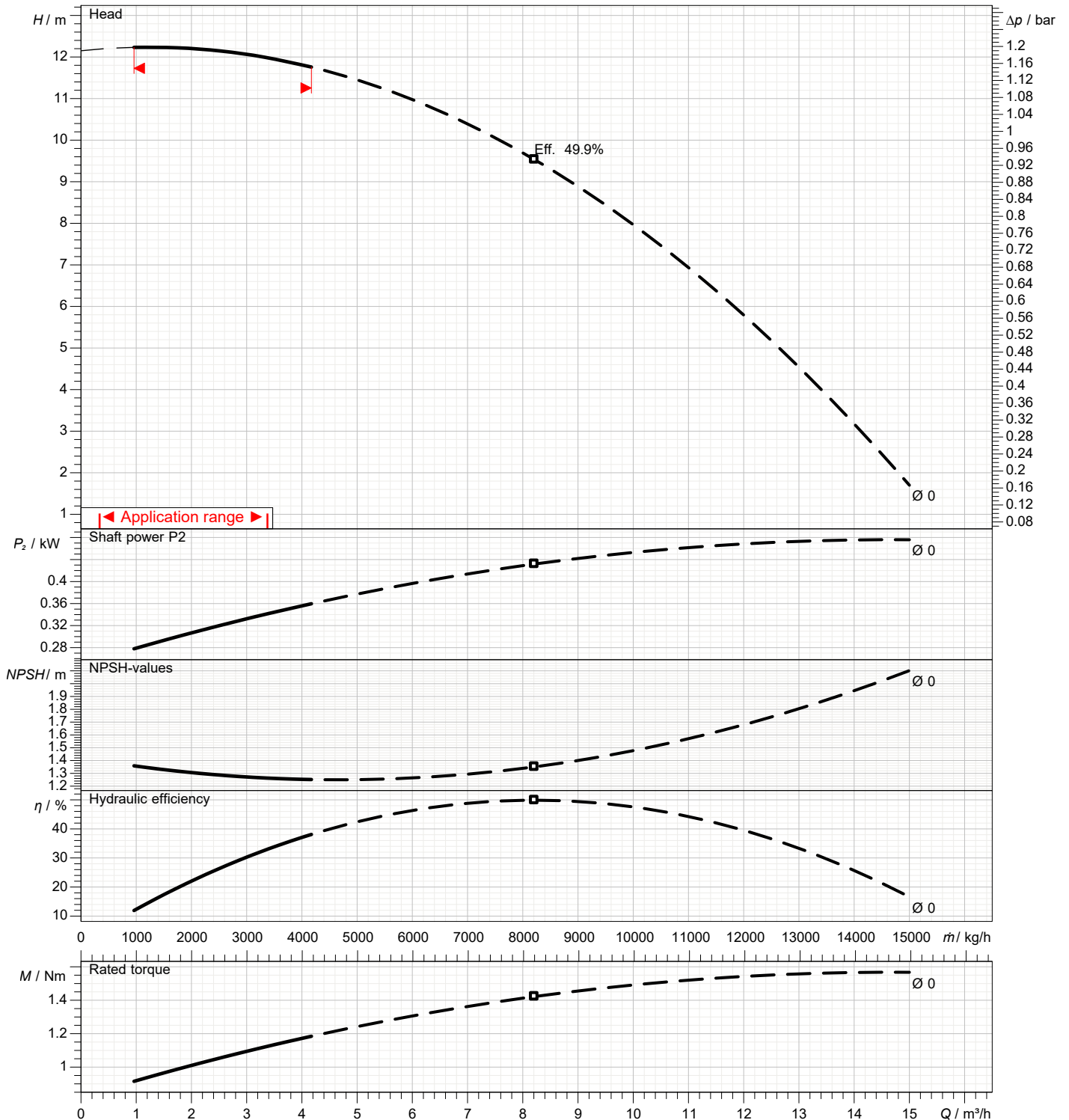

Dimensions

Pump name SWS 50 M

Customer	Date 2024-06-16	Company
Contact	Item no.	Issued by
Phone	Project	Phone
E-mail	Project ID Proiect redenumit 2024-06-16 15:45:44	E-mail

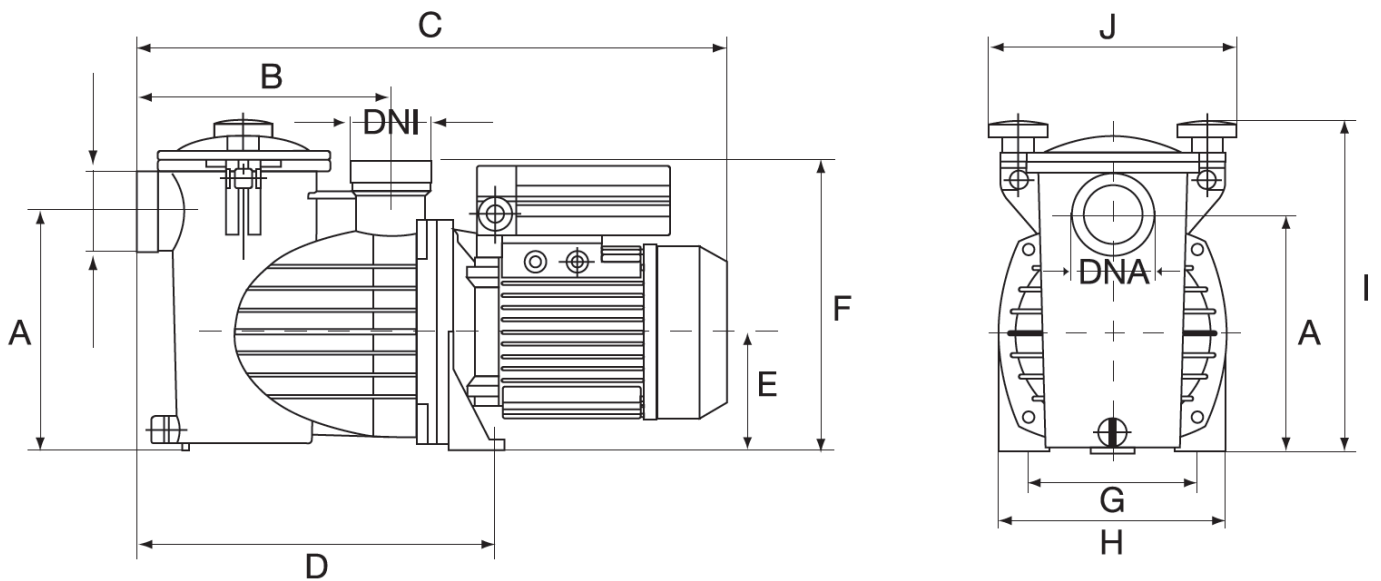

Dimensions in		mm						
1	A	191						
2	B	205						
3	C	470						
4	D	285						
5	DNA	1" 1/2						
6	DNI	1" 1/2						
7	E	95						
8	F	233						
9	G	140						
10	H	180						
11	I	265						
12	J	197						
13	Weight P&M	8,5 kg						
14								
15								

(1/1)

Construction

Pump name SWS 50 M

Customer	Date 2024-06-16	Company
Contact	Item no.	Issued by
Phone	Project	Phone
E-mail	Project ID Proiect redenumit 2024-06-16 15:45:44	E-mail

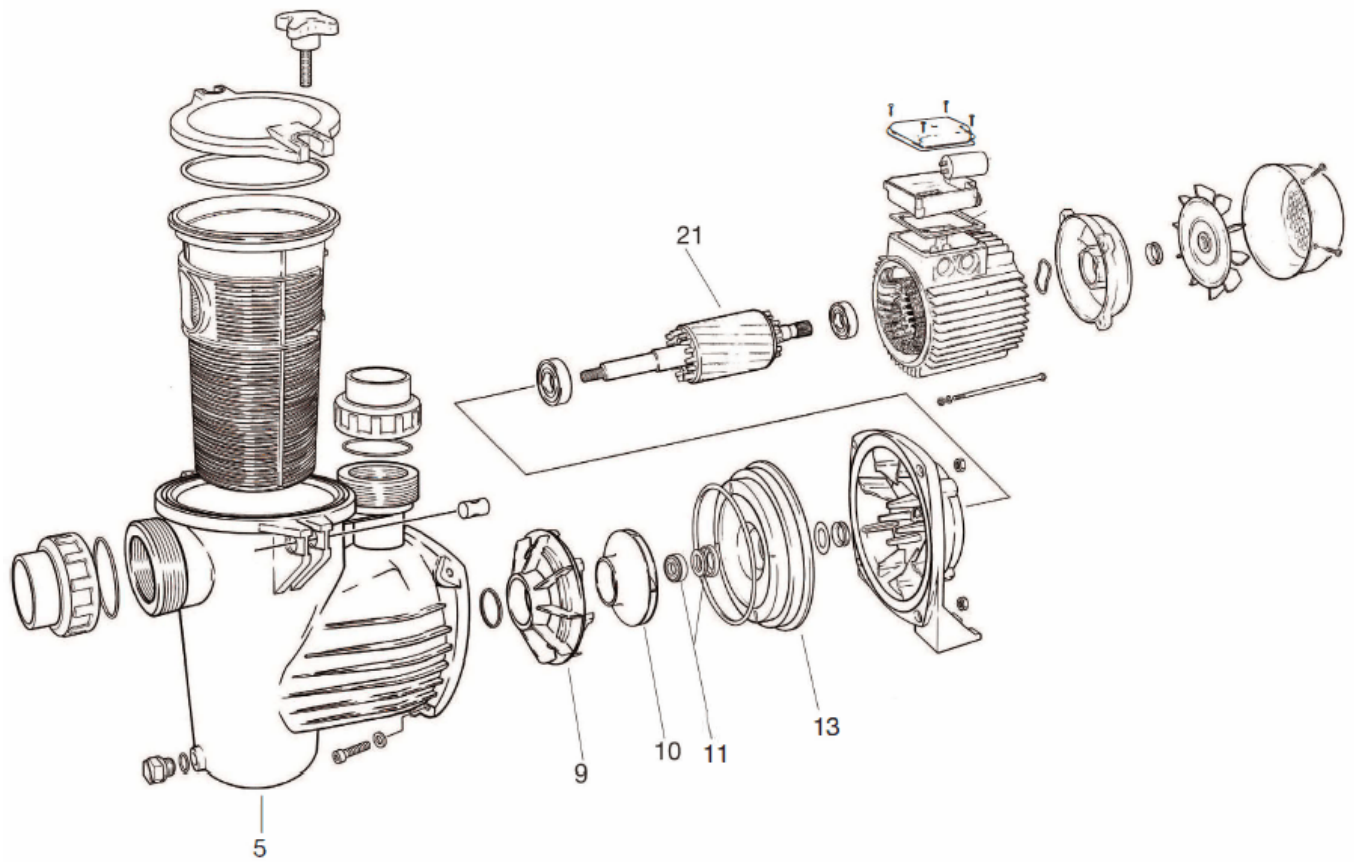

N°	PART NAME	MATERIAL
5	Pump body	Polypropylene reinforced with glass fibre
9	Diffuser	Polypropylene reinforced with glass fibre
10	Impeller	Noryl
11	Mechanical seal	Carbon / Ceramic / Stainless Steel AISI 316
13	Pump body lid	Polypropylene reinforced with glass fibre
18	Pump support	Aluminium
21	Shaft with rotor	Stainless steel AISI 316