

Technical data

Pump name

W86BHE 95-7/45 6

Customer	Date	2024-06-20	Company
Contact	Item no.		Issued by
Phone	Project		Phone
E-mail	Project ID	Proiect redenumit 2024-06-20 16:39:09	E-mail

Requested data

1	Pump type		SUBMERSIBLE DEEPWELL PUMP	Fluid		Water
2	Number of pumps / Reserve		1 / 0	Liquid temperature	°C	20
3	Flow	m³/h		Kin. viscosity	mm²/s	1.005
4	Head	m		Vapour pressure	bar	0.0234
5	Geodetic head	m		PH value		
6	Inlet pressure (pin)	bar	0	Density	kg/m³	998.3
7	Available system NPSH			Solids	Weight %	0
8	Ambient temperature	°C	20			

Pump

9	Pump name		W86BHE 95-7/45 6	Frequency	Hz	60	
10	Design		SUBMERSIBLE DEEPWELL PUMP	Installation type		STANDARD	
11	Manufacturer		EBARA	Impeller Diameter	Max.	mm	0
12	Speed	rpm	3460		Designed	mm	
13	No. of Stage		7		Min.	mm	0
14	Connection	Suction side		Flow	Operating	m³/h	
15	Connection	Discharge side			Max-	m³/h	150
16	Max Working Pressure	bar	70		Min-	m³/h	54
17	Shut-off head	bar	21.62	Head	Operating	m	
18	Total weight	kg	See the table of "Dimensions".		- (Qmax.)	m	72.8
19	Shaft power	kW	(Power / Stage)		- (Qmin.)	m	193.0
20				Max. Shaft Power at max. impeller	kW	6.81	(Power / Stage)
21	Required pump NPSH	m		Efficiency	%		

Materials

22	Impeller		EN 1.4401 (AISI 316)			
23	Discharge casing		EN 1.4301 (AISI 304)			
24	Shaft		EN 1.4301 (AISI 329)			
25	Diffuser		EN 1.4301 (AISI 304)			
26						
27						

Motor

28	Manufacturer		FRANKLIN	Insulation class		F
29	Type		BHE_6 inch_60_45_460_Three Phase	Phases		3~
30	Specific design		Submersible water filled type / 60 Hz / Pole pairs 1	Frame size		
31	Rated power	kW	45	Weight	kg	154
32	Number of poles		2	Electric voltage	V	460
33	Speed	rpm	3600	Electric current	A	91
34	Degree of protection		IP 68			
35						

Remarks

Performance curve

Pump name

W86BHE 95-7/45 6

Customer	Date	2024-06-20	Company
Contact	Item no.		Issued by
Phone	Project		Phone
E-mail	Project ID	Proiect redenumit 2024-06-20 16:39:09	E-mail

Requested data

1	Flow	m³/h	
2	Head	m	
3	Geodetic head	m	

Pump

Operating flow	m³/h		Frequency	Hz	60
Operating head	m		Number of poles		2
Impeller Diameter	Designed	mm	Speed	rpm	3460

Test standard: ISO 9906:2012 - Grade3B

Water; 20°C; 998.3kg/m³; 1mm²/s

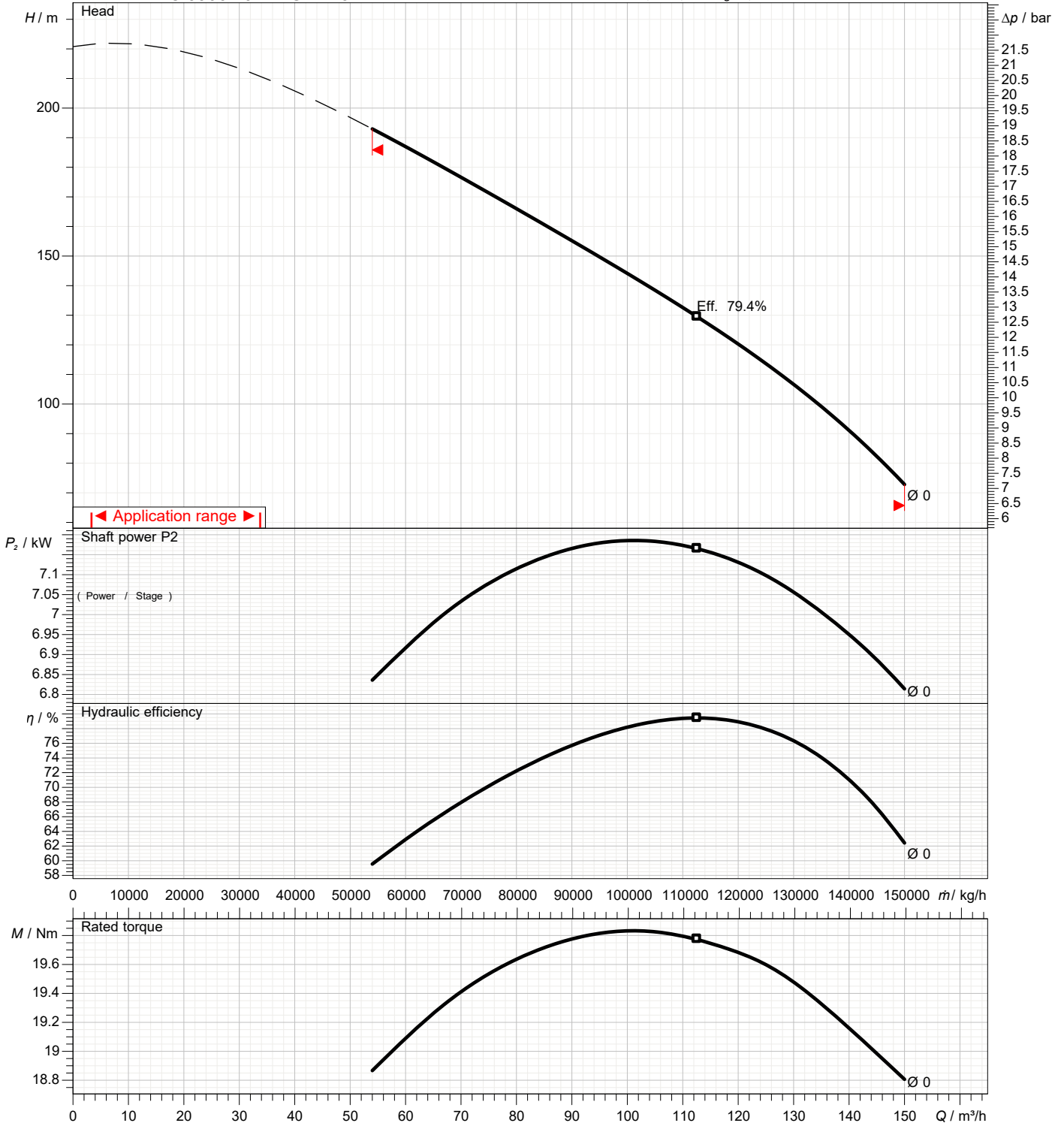

Dimensions

Pump name W86BHE 95-7/45 6

Customer	Date 2024-06-20	Company
Contact	Item no.	Issued by
Phone	Project	Phone
E-mail	Project ID Proiect redenumit 2024-06-20 16:39:09	E-mail

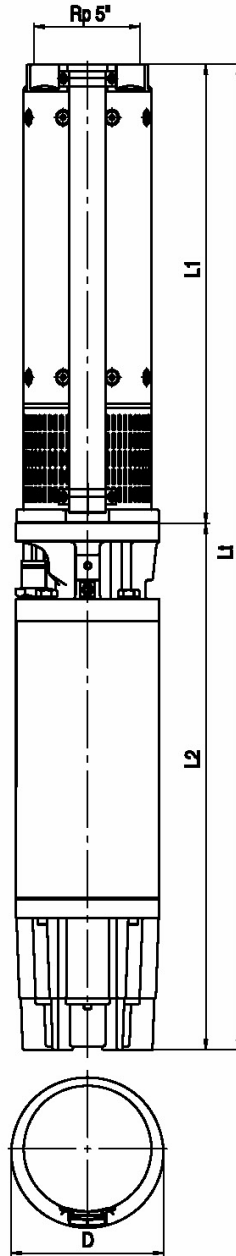

Dimensions in		mm						
1	D - 1 CABLE	186.5						
2	D - 2 CABLE	192						
3	L1	1274						
4	L2	1574						
5	Lt	2848						
6	Weight kg	362						
7								
8								
9								
10								
11								
12								
13								
14								
15								

(1/2) Construction

Pump name W86BHE 95-7/45 6

Customer	Date 2024-06-20	Company
Contact	Item no.	Issued by
Phone	Project	Phone
E-mail	Project ID Proiect redenumit 2024-06-20 16:39:09	E-mail

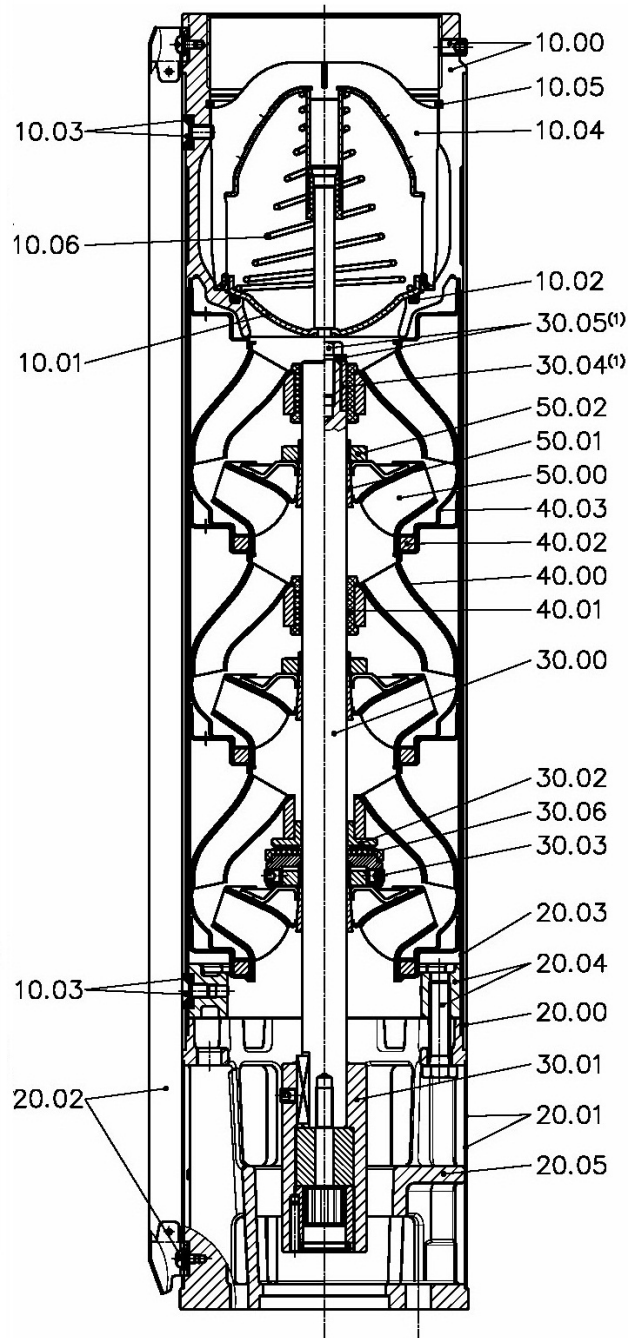

(1) Only for type with more than 8 stages

(2/2)

Construction

Pump name W86BHE 95-7/45 6

Customer	Date 2024-06-20	Company
Contact	Item no.	Issued by
Phone	Project	Phone
E-mail	Project ID Proiect redenumit 2024-06-20 16:39:09	E-mail

N°	PART NAME	MATERIAL		Q.TY
		Standard version	L version	
1000	Discharge head 5"	EN 1.4301 (AISI 304)	EN 1.4401 (AISI 316)	-
1001	Valve	EN 1.4401 (AISI 316)	EN 1.4401 (AISI 316)	-
1002	O-Ring	Nitrile rubber (NBR)	Nitrile rubber (NBR)	-
1003	Screw and inserts locking outer case	EN 1.4401 (AISI 316)	EN 1.4401 (AISI 316)	-
1004	Valve seat	EN 1.4401 (AISI 316)	EN 1.4401 (AISI 316)	-
1005	Seeger Ring	EN 1.4401 (AISI 316)	EN 1.4401 (AISI 316)	-
1006	Spring	EN 1.4401 (AISI 316)	EN 1.4401 (AISI 316)	-
2000	Outer casing	EN 1.4301 (AISI 304)	EN 1.4401 (AISI 316)	-
2001	Strainer	EN 1.4401 (AISI 316)	EN 1.4401 (AISI 316)	-
2002	Cable cover	EN 1.4401 (AISI 316)	EN 1.4401 (AISI 316)	-
2003	Spacer	EN 1.4401 (AISI 316)	EN 1.4401 (AISI 316)	-
2004	Flange and bolt	EN 1.4301 (AISI 304)	EN 1.4401 (AISI 316)	-
2005	Motor bracket	EN 1.4301 (AISI 304)	EN 1.4401 (AISI 316)	-
3000	Shaft	EN 1.4460 (AISI 329)	EN 1.4460 (AISI 329)	-
3001	Motor coupling	EN 1.4057 (AISI 431) + EN 1.4460 (AISI 329)	EN 1.4401 (AISI 316) + EN 1.4460 (AISI 329)	-
3002	Upper Up-thrust washer	EN 1.4460 (AISI 329)	EN 1.4460 (AISI 329)	-
3003	Lower Up-thrust washer	EN 1.4460 (AISI 329)	EN 1.4460 (AISI 329)	-
3004	Upper shaft sleeve (1)	Stainless steel with ceramic casting	Stainless steel with ceramic casting	-
3005	Screw and washer (1)	EN 1.4401 (AISI 316)	EN 1.4401 (AISI 316)	-
3006	Up-thrust disc	Teflon (PTFE)	Teflon (PTFE)	-
4000	Stage	EN 1.4301 (AISI 304)	EN 1.4401 (AISI 316)	-
4001	Intermediate bearing bush	Nitrile rubber (NBR)	Nitrile rubber (NBR)	-
4002	Liner ring	Teflon (PTFE)	Teflon (PTFE)	-
4003	Flange	EN 1.4401 (AISI 316)	EN 1.4401 (AISI 316)	-
5000	Impeller	EN 1.4401 (AISI 316)	EN 1.4401 (AISI 316)	-
5001	Split cone	EN 1.4401 (AISI 316)	EN 1.4401 (AISI 316)	-
5002	Split cone nut	EN 1.4401 (AISI 316)	EN 1.4401 (AISI 316)	-