

OPERATING INSTRUCTIONS

Conductivity meter

N-LF10 / N-LF100 / N-LF1000

These operating instructions apply to the following unit variants:

Article description	Measuring range	Article number
N-LF10, conductivity meter with integrated 3/4" screw-in measuring cell	0-10 μ S/cm	880559
N-LF100, conductivity meter with integrated 3/4" screw-in measuring cell	0-100 μ S/cm	880560
N-LF1000, conductivity meter with integrated 3/4" screw-in measuring cell	0-1000 μ S/cm	880561
N-LF10R, Conductivity meter with integrated 3/4" screw-in measuring cell and potential-free relay output	0-10 μ S/cm	880562
N-LF100R, conductivity meter with integrated 3/4" screw-in measuring cell and potential-free relay output	0-100 μ S/cm	880563
N-LF1000R, conductivity meter with integrated 3/4" screw-in measuring cell and potential-free relay output	0-1000 μ S/cm	880564
N-LF10W, conductivity meter with 3m hard-wired connection cable for external measuring cell	0-10 μ S/cm	880565
N-LF100W, conductivity meter with 3m hard-wired connection cable for external measuring cell	0-100 μ S/cm	880566
N-LF1000W, conductivity meter with 3m hard-wired connection cable for external measuring cell	0-1000 μ S/cm	880567
N-LF10WR, conductivity meter with 3m hard-wired connection cable for external measuring cell and potential-free relay output	0-10 μ S/cm	880568
N-LF100WR, conductivity meter with 3m hard-wired connection cable for external measuring cell and potential-free relay output	0-100 μ S/cm	880569
N-LF1000WR, conductivity meter with 3m hard-wired connection cable for external measuring cell and potential-free relay output	0-1000 μ S/cm	880570

TABLE OF CONTENTS

DESCRIPTION	Page 2
TECHNICAL DATA	Page 2
DISPLAY, OPERATION AND SETTINGS	Page 3
TERMINALS (FOR OPTIONS ONLY)	Page 4
ASSEMBLY AND OTHER OPERATING CONDITIONS	Page 5
CONDUCTIVITY MEASURING CELLS FOR N-LF METERS WITH EXTERNAL MEASURING CELL	Page 5

1. Description

Device for measuring the electrical conductivity of aqueous solutions in connection with two-electrode measuring cells without temperature compensation. Designed as a measuring device with integrated screw-in measuring cell or external measuring cell (W). Both versions are available with potential-free relay output (R).

- Application examples: Complete desalination, reverse osmosis
- Operation on 9 V DC via supplied plug-in power supply unit.
- Variants with relay output: 1 potential-free relay with switchable mode of operation of relay control
- Limit value display optically via LEDs

2. Technical data

- Measuring ranges: 0 - 10 / 100 / 1000 $\mu\text{S/cm}$, depending on the device type (see page 1)
- Limit value displays: Optical by means of LEDs, limit values adjustable between 0 and 100 % of the measuring range
- Accuracy N-LF10/100 (R/W/WR) series $\pm 10\%$ of full scale value
- Accuracy N-LF1000 (R/W/WR) series $\pm 5\%$ of full scale value
- Without temperature compensation
- Variants with relay output (R): 1 potential-free relay contact, max. 2 A / 250 V AC, 60 W / 62.5 VA
- Variants with external measuring cell (W): for this purpose, the measuring instrument is supplied with wall lugs and 3 m of hard-wired connection cable for the measuring cell, which must be ordered separately
- Power supply: 9 V DC via plug-in power supply unit 100 - 240 V AC
- Power consumption: approx. 1 W
- Protection class: IP 65
- Housing: Polycarbonate housing, 82 x 60 x 57 mm
- Connections: Side connections for plug-in power supply and for relay output
- Variant with mounted measuring cell:
 - o $\frac{3}{4}$ " thread, material PP, nominal pressure PN 6, Tmax. 60°C
 - o Material electrode pins: 1.4571

- Permissible operating pressure: 6 bar

3. Display, operation and settings

Display

- Display 2nd line: Conductivity in $\mu\text{S}/\text{cm}$
- Display 3rd and 4th line: Limit values 1 and 2
- If the permissible measuring range is exceeded: EEEE μS

LEDs

- G1 red: Conductivity limit value 1 exceeded
- G2 red: Conductivity limit value 2 exceeded

Setting the limit value:

- Press keys G1 and G2 simultaneously for 3 seconds Use key G1 to
- adjust limit value 1 Use key G2 to adjust limit value 2 approx. 5 seconds
- after the last actuation, both limit values are stored and the setting
- mode is locked The step size is 1% of the measuring range end value

-

Relay setting (variants with relay output):

Default setting

The relay is energized at conductivities above the set limit value G1 and de-energizes when the conductivity falls below the limit value or in the event of a voltage failure.

Manual operation, function test

Press and hold the G1 button, for the duration of the actuation the relay output changes the current operating state.

Setting the mode of operation of the relay

Press and hold the G2 button for 3 seconds. The display shows "Mode of operation relay" and in the bottom line "ON con>lim" (default) or "ON con<lim".

After releasing the key, the mode of operation is saved. Each new call via the G2 key changes the mode of operation (< or > lim) back accordingly.

Significance

ON switched on
con conductivity

> greater than <
smaller than lim limit
value 1

Reset:

Press the G1 key and put the unit into operation. The limit values are now reset to 50% of the measuring range end value and the mode of operation of the relay is set to "On LF>GW1".

Language setting (units delivered as of June 2021):

Press and hold the G1 and G2 buttons and start the appliance. In the first 5 seconds after switching on, release the G1 key and wait until the countdown has finished. Use G1 and/or G2 to select between German and English. After waiting two seconds, the current language is accepted and saved.

Calibration:

The devices are pre-calibrated. A correction is usually not necessary.

Operating conditions:

The electrode pins must be completely immersed and properly flowed around!
During installation, make sure that no air bubbles can form on the electrode pins.

4. Connection terminals

Connection of the power supply 9V DC

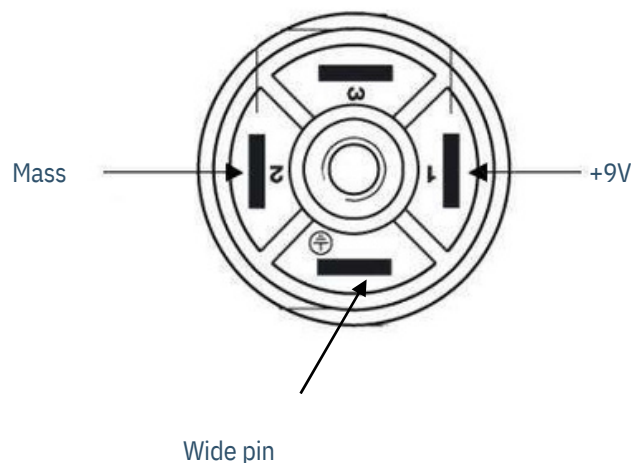

Connection of the potential-free relay connection (variants with relay output)

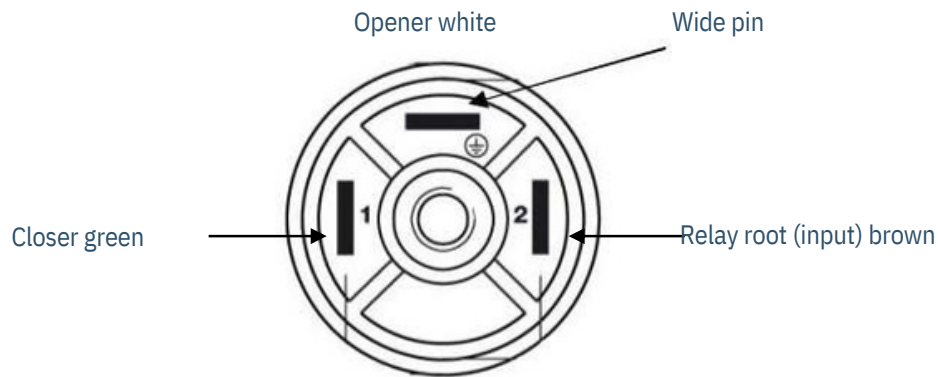

5. Mounting and other operating conditions

- With integrated measuring cell: Screw the measuring cell into the $\frac{3}{4}$ " socket using an SW 36 spanner
- Use the supplied O-ring or Teflon tape for sealing
- Lightly tighten the low voltage plug and relay plug (variant with relay output) with integrated seal on the unit
- Use the plug-in power supply outside of water-hazardous areas!

6. Conductivity measuring cells for N-LF units with external measuring cell (W / WR variants)

Cell constant ($\pm 10\%$)	For measuring range	Measuring cell with PT100	Article number	For measuring device
0.1	0 - 10 $\mu\text{S}/\text{cm}$	N-LF3401/PT100, 3/4"	880574	N-LF10 W / WR
		N-LF1201/PT100, 1/2"	880576	
0.1	0 - 100 $\mu\text{S}/\text{cm}$	N-LF3401/PT100, 3/4"	880574	N-LF100 W / WR
		N-LF1201/PT100, 1/2"	880576	
1.0	0 - 1000 $\mu\text{S}/\text{cm}$	N-LF3410/PT100, 3/4"	880575	N-LF1000 W / WR
		N-LF1210/PT100, 1/2"	880577	

Note: The PT100 of the above-mentioned measuring cells cannot be connected to the N-LF series W / WR units (measurement without temperature compensation).

Conductivity measuring cells ½" and ¾":

- Material electrode pins: 1.4571
 - Permissible operating pressure: 6 bar
 - Permissible temperature: 60 °C
 - Protection class plug: IP 65
 - Plug contacts: 2 electrodes
 - Operating conditions: The electrode pins must be completely immersed and flowed around!
electrodes 1 and 3 = temperature sensor
 - During installation, make sure that no air bubbles can form on the electrode pins
- Sensors with temperature sensor Pt100 can also be optionally designed with Pt1000
(Temperature sensor of the measuring cells is not used when connected to N-LF10 / N-LF100 / N-LF1000 meters)