

**Tender text**

**Project name**  
**Project ID**

**Customer**  
Contact  
E-mail  
Phone

**Company**  
Contact  
E-mail  
Phone

2025-01-20

Page 1 / 5

<b>Pos.no</b>	<b>Description</b>	<b>Item no.</b>
	<b>Volute casing pump</b>	
	Centrifugal pump: Etanorm 080-065-160/752 GG	05119879
	<b>Etanorm</b>	
	Horizontal single-stage volute casing pump, ratings to EN 733, radially split volute casing with integrally cast pump feet, long-coupled design. The pump is designed with replaceable casing wear rings, closed radial impeller with multiply curved vanes, single mechanical seal or double mechanical seals to EN 12756, shaft equipped with replaceable shaft protecting sleeve in the shaft seal area. The back pull-out design allows the coupling, bearing brackets and impeller to be dismantled without the need to disconnect the pump casing from the piping.	
	<b>Operating data</b>	
	Fluid handled	: Water
	Flow rate	:
	Head	:
	Fluid temperature	: 20,00 °C
	Permissible fluid temperature (min./max.)	: 0 bis +110
	Maximum operating pressure	: ≤ 16 bar
	Ambient temperature (min./max.)	: -10 to +50°C
	<b>Motor/electronics</b>	
	MEI value	: ≥ 0,4
	Motor rating	: 7,5 kW
	Max. rated current	: 14,6 A
	Speed	: 500 1/min ... 3.900 1/min
	Power supply	: 3 x 380 V AC - 15 % to 480 V AC +10 %
	Motor size	: 132S
	Energy efficiency class	:
	Enclosure	: IP55
	Motor make	: KSW - IEC
	<b>Materials</b>	
	Pump casing (102)	: Grey cast iron JL1040
	Impeller (230)	: Steel/tempered steel E335/C45
	Pump shaft (210)	: Grey cast iron JL1040
	Casing cover (161)	: Grey cast iron JL1040
	Casing wear ring, suction side (502.01):	DPAF seal plate, asbestos-



## Tender text

**Project name**

**Project ID**

**Customer**

Contact

E-mail

Phone

**Company**

Contact

E-mail

Phone

2025-01-20

Page 2 / 5

---

Pos.no	Description	Item no.	Qty.	UP / EUR	TP / EUR
	free				
	Casing wear ring, discharge side (502.02): Grey cast iron GG / cast iron				
	Shaft seal type				
	: Single mechanical seal, conical casing cover				
	Shaft seal material				
	:10 = Q1Q1X4GG				
	<b>Installation</b>				
	Installation type				
	: Baseplate for the entire pump set (pump + drive)				
	<b>Dimensions and connections</b>				
	Nominal size of discharge nozzle DN2				: DN 65
	Nominal diameter of suction nozzle DN1				: DN 80
	Nominal pressure, suction side				: 16
	Nominal pressure, discharge side				: 16
	<b>Purchase order information</b>				
	Approx. net weight				: 157,5 kg
	Make				: KSB
	Type				: Etanorm 080-065-160/752 GG
	Material price group				: 55
	<b>Material number</b>				: 05119879

---

**Data sheet: technical data**

**Project name**  
**Project ID**

**Item-No.**  
**Design**                    **Volute casing pump**  
**Type / Coding**           **Etanorm 080-065-160/752 GG**

**Customer**  
Contact  
E-mail  
Phone

**Company**  
Contact  
E-mail  
Phone

2025-01-20

Page 3 / 5

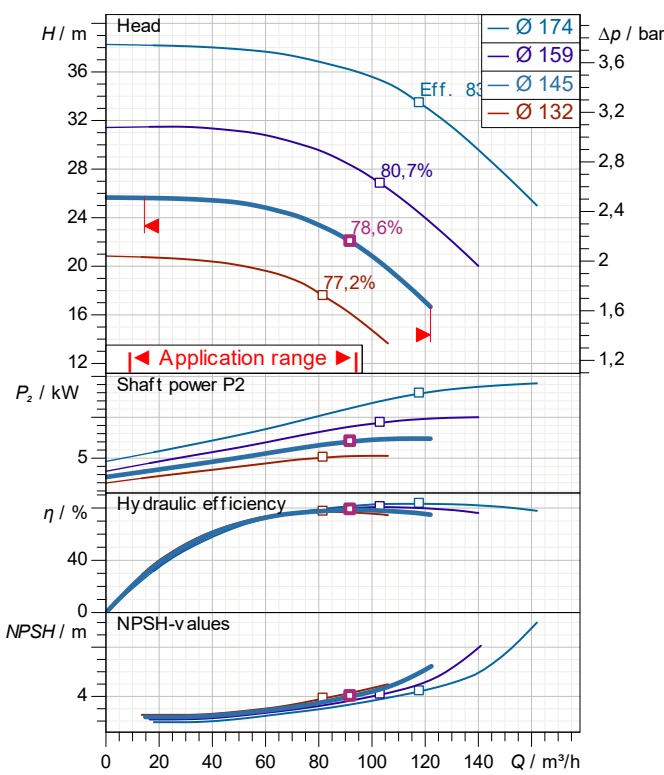

**demand data**

Flow  
Head  
Geodetic head  
Media                                Water  
Liquid temperature            20 °C  
Concentration                    100 %

**Pump data**

Make                                 KSB  
Type                                 Etanorm 080-065-160/752 GG  
Design                               Volute casing pump  
Specific design                    Single head pump  
Max. fluid temperature        140 °C

**Hydraulic data (Duty point)**

Flow  
Head  
Efficiency  
Minimum Efficiency Index       $\geq 0,4$

**Material / sealing element**

Volute casing                    Grey cast iron JL1040  
Discharge cover                Grey cast iron JL1040  
Shaft                                Steel/tempered steel E335/C45  
Impeller                            Grey cast iron JL1040  
Bearing bracket lantern        DPAF seal plate, asbestos-free  
Casing wear ring                Grey cast iron GG / cast iron

**Motor data**

Power uptake                    8,32 kW  
Rated power                      7,5 kW  
Speed                                2.935 1/min  
Rated voltage                    400 V  
Rated current                    14,6 A  
Degree of protection            IP55

**Product information**

Ident. No./ type key            05119879  
Weight loaded                    157,5 kg  
Gross price                        8.176,74 EUR  
PL 2025-01-20  
Price group                        55

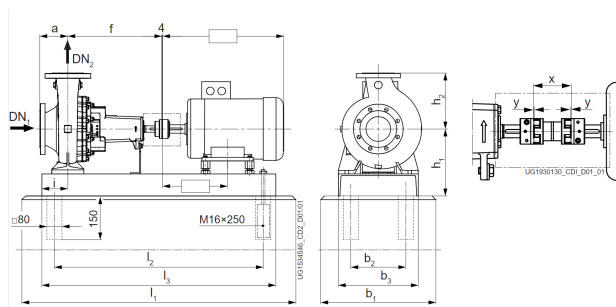

**Data sheet: performance curve**

**Project name**  
**Project ID**

**Item-No.**  
**Design**                    **Volute casing pump**  
**Type / Coding**           **Etanorm 080-065-160/752 GG**

**Customer**  
Contact  
E-mail  
Phone

**Company**  
Contact  
E-mail  
Phone

2025-01-20

Page 4 / 5

**Performance curve**

**Etanorm 080-065-160/752 GG**

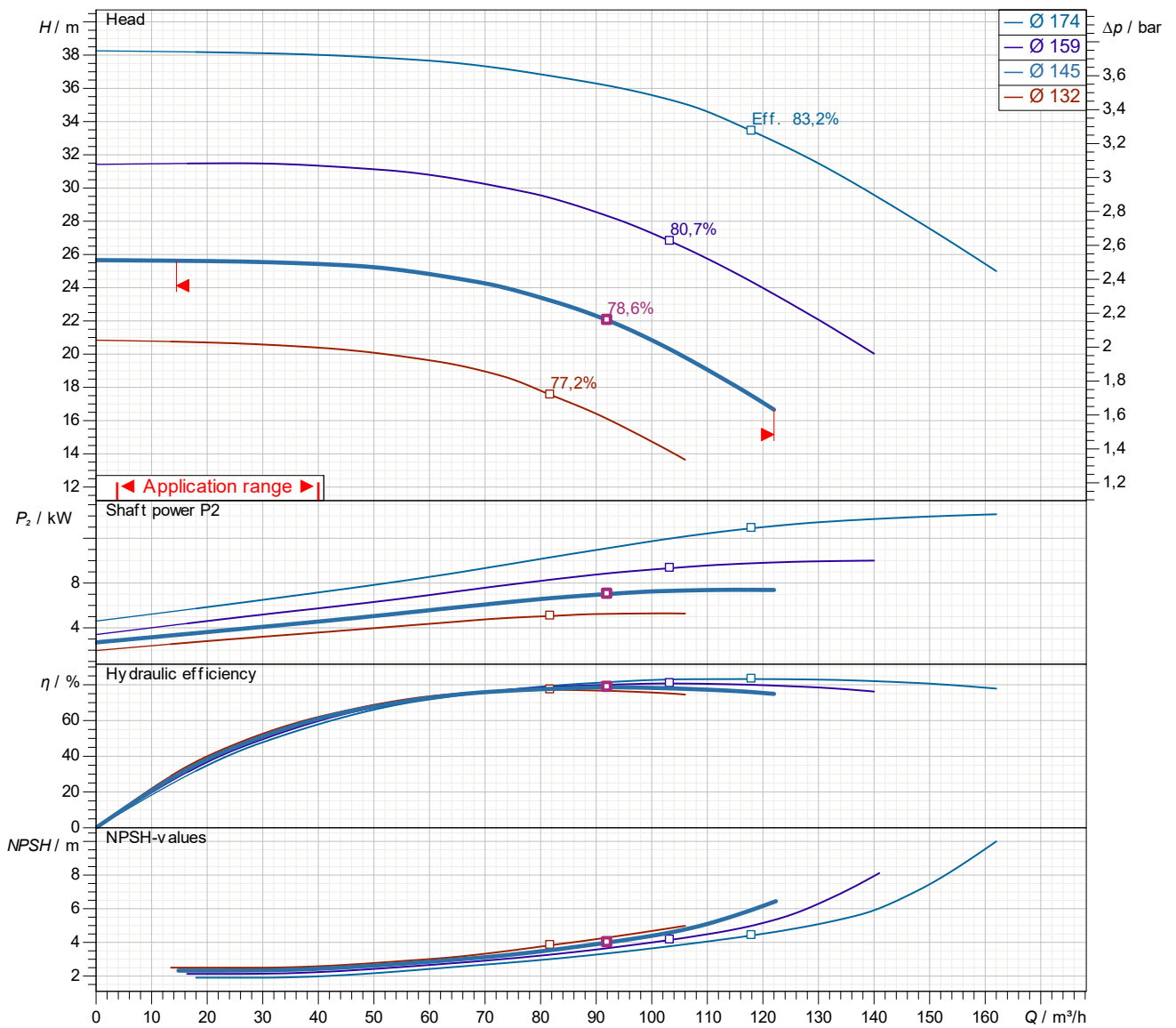

Density            998,3 kg/m<sup>3</sup>  
Viscosity        1,005 mm<sup>2</sup>/s

# Dimensions

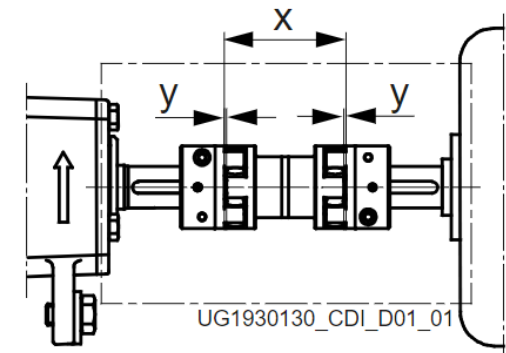
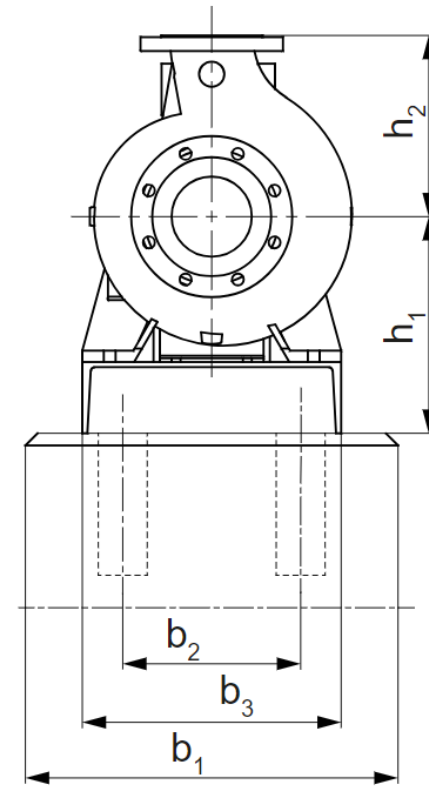
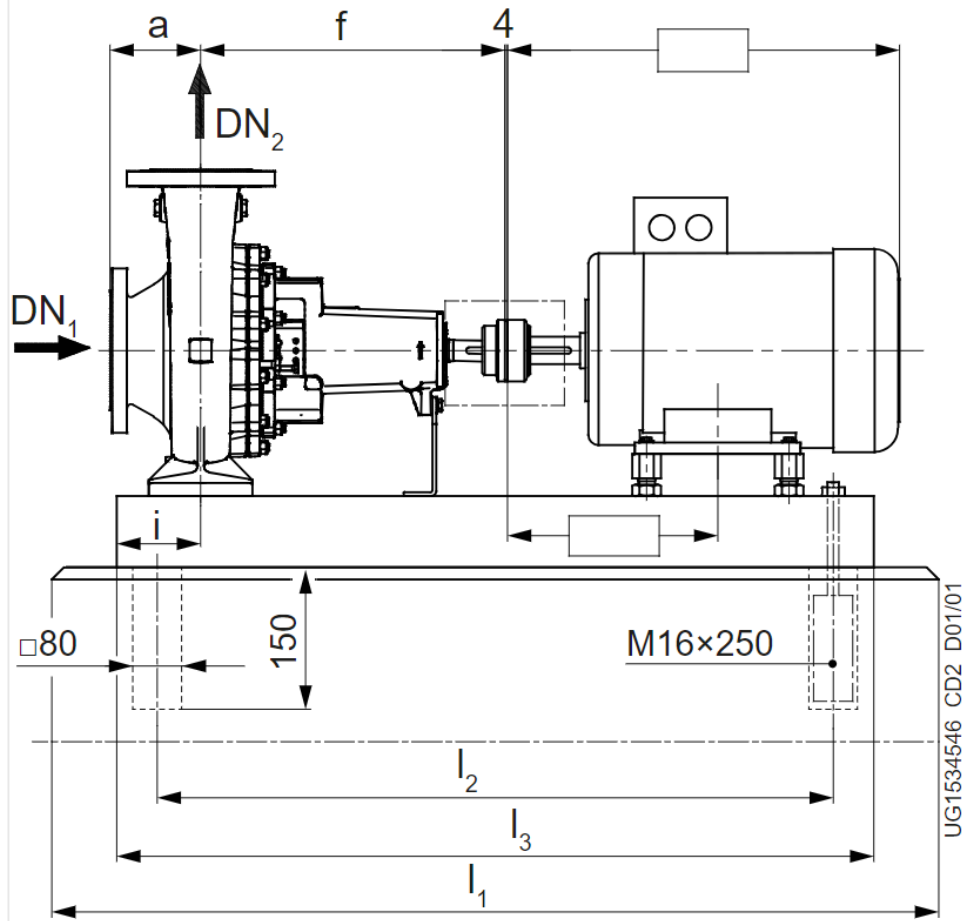

Name	Wert	Name	Wert
a	100 mm	l2	840 mm
b1	450 mm	l3	900 mm
b2	240 mm	x	100 mm
b3	300 mm		
DN1	80 mm		
DN2	65 mm		
f	360 mm		
h1	260 mm		
h2	200 mm		
i	112 mm		
l1	1.050 mm		