



Tender text

Project name
Project ID

Customer
Contact
E-mail
Phone

Company
Contact
E-mail
Phone

2025-01-20

Page 1 / 5

Pos.no	Description	Item no.
	Submersible dirty water motor pumps	
	Amarex Fmax 065-170/073 F 2 YS G	39120094
	Amarex KSB submersible motor pump for waste water applications, in grey cast iron and special materials	
	Vertical submersible motor pump set for wet installation, single-stage, with three-phase motor to IEC standards. Temperature sensor for protection against overheating, optional leakage sensor in the motor space, power cable with resin-sealed, absolutely water-tight cable entry and service-friendly plug-type connection in the motor space.	
	Pump set:	
	Make	: KSB
	Impeller	: Amarex F / 065-170
	type	: F-max vortex impeller
	F-max is a vortex impeller optimised for operating reliability. With its large free passage of 100 mm max. it is especially suitable for handling waste water containing all kinds of solids and fibres.	
	Impeller diameter	: 190 mm
	Free passage	: 65 mm
	Operating data:	
	Fluid handled	: Water
	Flow rate	:
	Head	:
	Power input	: 8,72 kW
	Operating temperature	: 40 °C max.
	Drive:	
	Nominal voltage	: 3~400 V
	Nominal frequency	: 50 Hz
	Starting method	: DOL / star-delta starting is also possible
	Enclosure	: IP68 to EN 60529 / IEC 529,

Tender text

Project name
Project ID

Customer
Contact
E-mail
Phone

Company
Contact
E-mail
Phone

2025-01-20

Page 2 / 5

Pos.no	Description	Item no.	Qty.	UP / EUR	TP / EUR
		thermal class H			
	Explosion protection	: ATEX II 2G Ex db h IIB T4 Gb			
	Max. fluid temperature	: 40 °C			
	Thermal motor protection	: Temperature sensor			
	Leakage sensor in the motor space	: no			
	Efficiency class	:			
	Duty type	: S1 submerged / with motor section partly outside the fluid			
	Motor rating P2	: 7,3 kW			
	Motor rating P1	: 8,72 kW			
	Motor efficiency	: 83,7%			
	Nominal current	: 14,70 A			
	Speed	: 2.812 1/min			
	Cable length	: 10 m			
	Cable entry with individually stripped, friendly plug-type	: Screwed cable entry / cable entry resin-embedded cores and service-connection inside the motor			
	Materials:				
	Pump casing Class 35B)	: Grey cast iron EN-GJL-250 (A 48			
	Handle	: 1.4306			
	Impeller Class 35B)	: Grey cast iron EN-GJL-250 (A 48			
	Discharge cover Class 35B)	: Grey cast iron EN-GJL-250 (A 48			
	Suction cover Class 35B)	: Grey cast iron EN-GJL-250 (A 48			
	Shaft	: 1.4021			
	Cable sheath	: Chloroprene rubber			
	Elastomer seals	: Nitrile-butadiene-rubber NBR			
	Coating	: Two-component high-solid epoxy resin			
	Colour	: RAL 5002			
	Shaft seal:				
	2 independent mechanical seals arranged in the oil reservoir				
	Pump end	: Bellows-type mechanical seal			



Tender text

Project name
Project ID

Customer
Contact
E-mail
Phone

Company
Contact
E-mail
Phone

2025-01-20

Page 3 / 5

Pos.no	Description	Item no.	Qty.	UP / EUR	TP / EUR
	Motor end Carbon-Al2O3 Oil fill	: Bellows-type mechanical seal, : Environmentally friendly, non-toxic oil			
	Dimensions and connections:				
	Nominal size	: PN 16			
	Discharge side				
	Nominal size	: DN 65			
	Suction side				
	Weight	: 93 kg			
	Pump				
	Purchase order information:				
	Make	: KSB			
	Type series / size	: Amarex F065-170			
	Material price group	: 18			
	Weight	: 93 kg			
	Item number	: 39120094			
	Motor: 732YSG		1		
	MOTOR				
	The motor shall be three-phase, dry squirrel-cage induction type in design conforming to IEC / VDE / EN standards. The motor shall be adequately sized and rated for continuous operation to maximum a fluid temperature of 40 °C (104 °F).				
	The motor housing shall be both air filled and watertight. Motor protection shall be at minimum IP 68. Allowable maximum submergence shall be not less than 25 m.				
	The motor shall be rated for supply voltage of 400 V and frequency of 50 Hz and accept voltage fluctuations as per range A of DIN EN 60 034-1 (Supply voltage +/-10 supply frequency -5%/+3%). The motor shall be explosionproof to ATEX II 2G T4, EEX d II B.				
	The motor shall be designed for a maximum of 30 number of starts per hour. Starting of the motor shall be direct.				
	The motor stator shall be wound to have an overall motor rating of 155°C, Class H. The rotor bars and short circuit rings shall be made of cast aluminum.				
	The motor and pump set complete shall be designed and manufactured by the same company.				
	MOTOR THERMAL PROTECTION				
	Temperature monitors shall be embedded in the motor windings for use in conjunction with and supplemental to external motor overload protection.				



Tender text

Project name
Project ID

Customer
Contact
E-mail
Phone

Company
Contact
E-mail
Phone

2025-01-20

Page 4 / 5

Pos.no	Description	Item no.	Qty.	UP / EUR	TP / EUR
	<p>These temperature sensitive switches shall allow for direct integration with the motor control circuit to shut down the pump if high temperatures are detected. The switches shall be normally closed rated for 250 V AC and a current of not less than 2 A. Additional temperature sensitive switches shall be embedded in the motor winding to limit temperatures of the motor as per explosion-proof certification. The pump's control shall shut down the pump should any of the monitors detect high temperature. Automatic reset shall not be allowed.</p> <p>MOTOR HOUSING MOISTURE PROTECTION A moisture detector shall be mounted in the motor's stator cavity allowing a control panel mounted relay to de-energize the motor when a leakage occurs.</p>				

Data sheet: technical data

Project name
Project ID

Item-No.

Design
Type / Coding

Submersible dirty water motor pumps
Amarex Fmax 065-170/073 F 2 YS G

Customer
Contact
E-mail
Phone

Company
Contact
E-mail
Phone

2025-01-20

Page 5 / 5

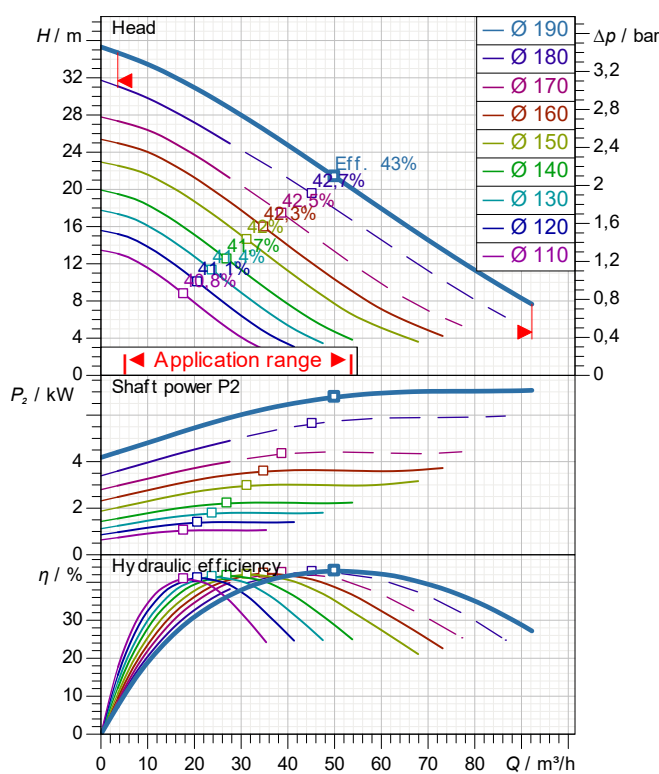

demand data

Flow
Total head
Geodetic head
Media
Liquid temperature

Water
20 °C

Pump data

Make
Type
Design
Specific design
No. of pumps
Standby pump
Max. fluid temperature

KSB
Amarex Fmax 065-170/073 F 2 YS G
Submersible dirty water motor p
Single head pump
1
No
40 °C

Hydraulic data (Duty point)

Flow
Head

Material / sealing element

Casing
Cover
Suction cover material
Discharge cover
Shaft
Impeller
O-Rings

Grey cast iron EN-GJL-250 (A 48 Class 35B)
Grey cast iron EN-GJL-250 (A 48 Class 35B)
Grey cast iron EN-GJL-250 (A 48 Class 35B)
Grey cast iron EN-GJL-250 (A 48 Class 35B)
1.4021
Grey cast iron EN-GJL-250 (A 48 Class 35B)
Nitrile-butadiene-rubber NBR

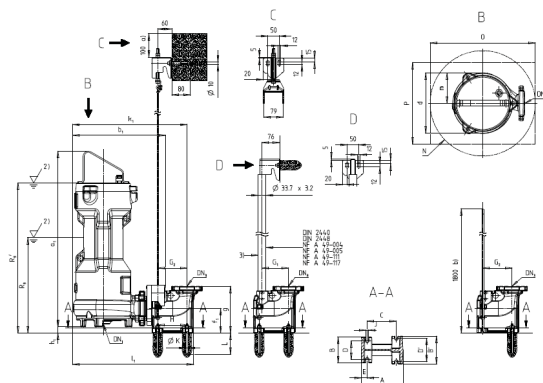

Dimensions

Discharge flange standard DN 65

Rated motor data

Power input (P1)
Rated power (Pn)
Speed
Rated voltage
Rated current (In)

8,72 kW
7,3 kW
2.812 1/min
400 V
14,7 A

Product information

Ident. No./ type key
Weight loaded
Gross price
PL 2025-01-20
Price group

39120094
93 kg
8.895,40 EUR