

Closed-coupled Pump

Etabloc

Fixed Speed / Variable Speed
50 Hz / 60 Hz

Type Series Booklet



Legal information/Copyright

Type Series Booklet Etabloc

All rights reserved. The contents provided herein must neither be distributed, copied, reproduced, edited or processed for any other purpose, nor otherwise transmitted, published or made available to a third party without the manufacturer's express written consent.

Subject to technical modification without prior notice.

© KSB SE & Co. KGaA, Frankenthal 2024-02-26

Contents

Centrifugal Pumps with Shaft Seal.....	4
Close-coupled Pump.....	4
Etabloc (EU / ME / NA).....	4
Main applications.....	4
Fluids handled.....	4
Related documents.....	4
Operating data.....	4
Design details.....	4
Designation.....	6
Materials.....	8
Coating and preservation.....	9
Product benefits.....	9
Product information.....	9
Product information as per Regulation No. 1907/2006 (REACH).....	9
Product information as per Regulation No. 547/2012 (for water pumps with a maximum shaft power of 150 kW) implementing "Ecodesign" Directive 2009/125/EC.....	9
Acceptance tests and warranty.....	9
Overview of product features / selection tables.....	10
Overview of variants.....	10
Overview of fluids handled.....	11
Overview of materials.....	13
Overview of pump size / motor combinations.....	14
Overview of functions for variable speed version.....	18
Pressure limits and temperature limits.....	19
Technical data.....	20
Etabloc.....	20
Selection charts.....	21
Etabloc, n = 2900 rpm (fixed speed version).....	21
Etabloc, n = 1450 rpm (fixed speed version).....	21
Etabloc, n = 960 rpm (fixed speed version).....	22
Etabloc, n = 3500 rpm (fixed speed version).....	22
Etabloc, n = 1750 rpm (fixed speed version).....	23
Etabloc, n = 1160 rpm (fixed speed version).....	23
Connections.....	24
Discharge nozzle positions.....	28
Flange design.....	28
Installation types.....	31
Scope of supply.....	33
Recommended spare parts stock.....	33
General assembly drawings.....	34
Version with single mechanical seal and bolted casing cover.....	34
Version with single mechanical seal and clamped casing cover.....	36
Version with double mechanical seal in back-to-back arrangement.....	38
Version with double mechanical seal in tandem arrangement.....	39

Centrifugal Pumps with Shaft Seal

Close-coupled Pump

Etabloc (EU / ME / NA)



i The product illustrated as an example may include options incurring a surcharge.

Main applications

- Handling clean or aggressive fluids not chemically and mechanically aggressive to the pump materials.
- Water supply systems
- Cooling circuits
- Swimming pools
- Fire-fighting systems
- General irrigation systems
- Drainage systems
- Heating systems
- Air-conditioning systems
- Spray irrigation systems

Fluids handled

- Seawater
- Brackish water
- Drinking water
- Hot water
- Service water
- Fire-fighting water
- Brine
- Cleaning agents
- Condensate
- Oils

Related documents

Table 1: Information/documents

Document	Reference number
General arrangement drawings booklet	1173.391
Characteristic curves booklet (50 Hz) Fixed speed version	1311.45
Characteristic curves booklet (60 Hz) Fixed speed version	1311.46
Characteristic curves booklet Variable speed version	1311.452
Type series booklet KSB SuPremE	4075.53
Type series booklet PumpDrive 2 / PumpDrive 2 Eco	4074.5
Type series booklet PumpDrive R	4073.5
Type series booklet PumpMeter	4072.5

Operating data

Table 2: Operating properties

Characteristic		Value	
		50 Hz	60 Hz
Flow rate	Q [m ³ /h]	≤ 660	≤ 740
Head	H [m]	≤ 160	≤ 148
Fluid temperature	T [°C]	≥ -30	≥ -30
		≤ +140	≤ +140
Operating pressure	p [bar]	≤ 16	≤ 16
Motor rating ¹⁾	P _N [kW]	≤ 110	≤ 110

Design details

Design

- Volute casing pump
- Single-stage
- Ratings to EN 733
- Requirements to 2009/125/EC Directive
- Fixed speed version (without PumpDrive 2 / PumpDrive 2 Eco / PumpDrive R) / variable speed version (with PumpDrive 2 / PumpDrive 2 Eco / PumpDrive R)

Pump casing

- Radially split volute casing
- Volute casing with integrally cast pump feet (not for pump casing material G, motor size ≤ 180)
- Replaceable casing wear rings (optional for pump casing material C)

Drive (fixed speed version)

Standard design:

- KSB/Innomotics surface-cooled IEC three-phase current squirrel-cage motor
- Efficiency class IE2 (size 71)/ IE3 up to 55 kW and from 250 kW/ IE4 from 75 kW to 200 kW to IEC 60034-30
- Rated voltage (50 Hz) 230 V / 400 V ≤ 2.20 kW

¹ Refer to the overview of pump size / motor combinations

- Rated voltage (50 Hz) 400 V / 690 V \geq 3.00 kW
- Rated voltage (60 Hz) - / 460 V \leq 2.20 kW
- Rated voltage (60 Hz) 460 V / - \geq 3.00 kW
- Type of construction IM V1 \leq 4.00 kW
- Type of construction IM V15 \geq 5.50 kW
- Enclosure IP55
- Duty type: continuous duty S1
- Thermal class F with temperature sensor, 1 PTC thermistor (size 80/90) / 3 PTC thermistors (from size 100)

Explosion-proof design:

- KSB surface-cooled IEC three-phase current squirrel-cage motor
- Efficiency class IE3 to IEC 60034-30
- Rated voltage (50 Hz) 230 V / 400 V \leq 2.50 kW
- Rated voltage (50 Hz) 400 V / 690 V \geq 3.30 kW
- Rated voltage (60 Hz) - / 460 V \leq 2.50 kW
- Rated voltage (60 Hz) 460 V / - \geq 3.30 kW
- Type of construction IM V1 \leq 4.00 kW
- Type of construction IM V15 \geq 5.50 kW
- Enclosure IP55
- Duty type: continuous duty S1
- II 3G Ex ec IIC T3 Gc
- II 2G Ex eb IIC T3 Gb
- II 2G Ex db (eb) IIB T4 Gb
- II 2G Ex db (eb) IIC T4 Gb

Drive (variable speed version)
KSB SuPremE motor:

- Surface-cooled KSB SuPremE motor, IEC-compatible, magnetless synchronous reluctance motor²⁾ (PumpDrive required)
- Efficiency class IE4 / IE5 to IEC TS 60034-30-2:2016
- Mounting points to EN 50347:2001
- Envelope dimensions to DIN VDE 42673-4:2011-07
- Type of construction IM V1 \leq 4.00 kW
- Type of construction IM V15 \geq 5.50 kW
- Enclosure IP55
- Duty type: continuous duty S1
- Thermal class F with temperature sensor, 3 PTC thermistors
- Shaft centreline height 71 to 225 mm
- Rated power 0.55 kW to 45 kW
- Rated speed 1500 rpm or 3000 rpm
- Frequency 50 Hz / 60 Hz (PumpDrive input)
- Voltage 380 V to 480 V (PumpDrive input)

KSB SuPremE C1/D1:

- With terminal box for connecting to PumpDrive 2 or PumpDrive R for mounting on walls and in control cabinets

KSB SuPremE C2/D2:

- Equipped for being fitted with a motor-mounted PumpDrive 2

PumpDrive 2 / PumpDrive 2 Eco:

- Self-cooling frequency inverter of modular design for the continuously variable speed control of asynchronous motors and synchronous reluctance motors by means of analog standard signals, a field bus or the control panel
- Identical design of frequency inverter for motor mounting, wall mounting and cabinet mounting
- Mains voltage 3~ 380 V AC -10 % to 480 V AC +10 %
- Mains frequency 50 Hz to 60 Hz \pm 2 %

PumpDrive R:

- Self-cooling frequency inverter of modular design for the continuously variable speed control of asynchronous motors and synchronous reluctance motors, such as KSB SupremE motors or permanent magnet synchronous motors, by means of analog standard signals, a field bus or the control panel
- Identical design of frequency inverter for the mounting types wall mounting and cabinet mounting
- Mains voltage 3~ 380 V AC -10 % to 480 V AC +10 %
- Extended mains voltage range (on request)
- Mains frequency 50 Hz to 60 Hz \pm 2 %
- Extended power range with a nominal power of 110 kW (standard) or 1400 kW (on request)

PumpMeter:

- Intelligent pressure transmitter for pumps, with on-site display of measured values and operating data
- For recording the load profile of the pump
- Supplied completely assembled and parameterised for the individual pump

KSB Guard

- System for monitoring the pump's condition by means of temperature and vibration sensors
- Measured values and operating data may be retrieved via the KSB Guard app and the web portal at any time.

Shaft seal

- Single mechanical seals and double mechanical seals to EN 12756
- Shaft equipped with replaceable shaft sleeve in the shaft seal area

Impeller type

- Closed radial impeller with multiply curved vanes

²⁾ Motor sizes 0.55 kW / 0.75 kW with 1500 rpm are designed with permanent magnets.

Designation
Table 3: Designation example

Position																															
1	2	3	4	5	6	7	8	9	10	11	12	13	14	15	16	17	18	19	20	21	22	23	24	25	26	27	28	29	30	31	32
E	T	B		0	4	0	-	0	2	5	-	1	6	0	-	G	G	S	B	E	1	1	W	S	E	J	B	2	H	C	B
See name plate and data sheet																															

Table 4: Designation key

Position	Code	Description
1-4	Pump type	
	ETB	Etabloc
	ETBF	Etabloc bottle rinser variant
5-16	Size [mm], e.g.	
	040	Nominal suction nozzle diameter
	025	Nominal discharge nozzle diameter
	160	Nominal impeller diameter
17	Pump casing material	
	B	Bronze CC480K-GS / B30 C90700
	C	Stainless steel 1.4408 / A743CF8M
	G	Cast iron EN-GJL-250 / A48 Cl. 35
	K	Cast iron, electrocoated EN-GJL-250, electrocoated
	S	Nodular cast iron EN-GJS-400-15 / A536 Gr. 60-40-18
18	Impeller material	
	B	Bronze CC480K-GS / B30 C90700
	C	Stainless steel 1.4408 / A743CF8M
	G	Cast iron EN-GJL-250 / A48 Cl. 35
	P	Cast iron without protective coating EN-GJL-250 without protective coating
19	Description	
	E	Design as per European Regulation (EC) No. 1935/2004
	F	Bottle rinser variant
	H	Approved for drinking water to ACS
	K	Approved for drinking water to KSB standard
	P	Swimming pool variant
	S	Standard
	U	Approved for drinking water to UBA
W	Approved for drinking water to WRAS	
20	Casing cover connections	
	A	Single mechanical seal, conical cover without internal circulation
	B	Conical casing cover with connection for venting
	C	Conical casing cover with vent
	D	Conical casing cover with connection for external flushing
	E	Conical casing cover with connection for external flushing from discharge nozzle
	H	Cylindrical casing cover for version with double mechanical seal in tandem arrangement with connection for quench system
	I	Cylindrical casing cover for version with double mechanical seal in back-to-back arrangement with connection for barrier fluid system
21	Shaft seal type	
	D	Double mechanical seal in back-to-back arrangement, API Plan: 53A
	E	Single mechanical seal, external circulation, conical casing cover, API Plan: 11
	F	Single mechanical seal, external flushing, conical casing cover, API Plan: 32
	I	Single mechanical seal, internal circulation, conical casing cover, API Plan: 01
	T	Double mechanical seal in tandem arrangement with internal circulation, API Plan: 52 ³⁾ / 55 ⁴⁾
	V	Single mechanical seal with vented chamber (A-type cover), API Plan: 03
22-23	Seal code, single mechanical seal	
	01	QQVGG KSB's choice $\geq -20 - \leq +110$ [°C]
	07	QQEGG DW001 KSB's choice $\geq -30 - \leq +110$ [°C]

³ Applies to: Version without reservoir and version with unpressurised reservoir

⁴ Applies to: Version with external circulation system

Position	Code	Description			
22-23	09	U3U3VGG-Y10	EMG13-G6	≥ -20 - ≤ +110 [°C]	
	10	QQXGG	KSB's choice	≥ -20 - ≤ +110 [°C]	
	11	BQEGG DW001	KSB's choice	≥ -30 - ≤ +110 [°C]	
	12	Q12Q1M1GG1	M37GN83	≥ -20 - ≤ +100 [°C]	
	13	BQVGG	KSB's choice	≥ -20 - ≤ +110 [°C]	
	14	Q1Q1KY7G	KMB13S2G9	≥ -20 - ≤ +120 [°C]	
	15	Q1Q1KGG	M7G49	≥ -20 - ≤ +110 [°C]	
	17	Q1BVGG	M7N / 5A	≥ -20 - ≤ +110 [°C]	
	22	AQ1EGG	M32N69	≥ -30 - ≤ +140 [°C]	
	45	BQ7EGG-Y10 FD004	EMG13-G6	≥ -30 - ≤ +110 [°C]	
	46	Q7Q7EGG-Y10 FD004	EMG13-G6	≥ -30 - ≤ +110 [°C]	
	51	BQ7VGG-Y10 FD004	EMG13-G6	≥ -14 - ≤ +120 [°C]	
	52	Q7Q7VGG-Y10 FD004	EMG13-G6	≥ -14 - ≤ +120 [°C]	
	66	Q7Q7EGG-Y10 DW001	EMG13-G6	≥ -30 - ≤ +120 [°C]	
	76	AQ7EGG-Y10	ERMG13-G6	≥ -30 - ≤ +140 [°C]	
	79	Q7Q7VGG-Y10	EMG13-G6	≥ -20 - ≤ +110 [°C]	
	Seal code, double mechanical seal in tandem arrangement				
	18	Q7Q7EGG-Y10 DW001	EMG12-G6	≥ -30 - ≤ +110 [°C]	
		Q7Q7EGG-Y10 DW001	EMG12-G6	≥ -30 - ≤ +110 [°C]	
	20	Q12Q1M1GG1	M37GN85	≥ -20 - ≤ +110 [°C]	
		Q7Q7EGG-Y10 DW001	EMG12-G6	≥ -20 - ≤ +110 [°C]	
	23	Q12Q1M1GG1	M37GN92	≥ -20 - ≤ +110 [°C]	
		Q7Q7EGG-Y10 DW001	EMG12-G6	≥ -20 - ≤ +110 [°C]	
	Seal code, double mechanical seal in back-to-back arrangement				
	21	Q1Q1KGG	M7G49	≥ -20 - ≤ +110 [°C]	
		Q1Q1KGG	M7G49	≥ -20 - ≤ +110 [°C]	
	24	Q1Q1KGG	M7G49	≥ -20 - ≤ +110 [°C]	
Q1BVGG		M7N	≥ -20 - ≤ +110 [°C]		
24	Type of lubrication				
	W	None			
25	Design				
	C	Extended standard			
	S	KSB standard			
	X	Special design			
26	Bearing bracket/shaft unit				
	E	Shaft unit 25			
	F	Shaft unit 35			
	H	Shaft unit 55			
27-28	Motor rating P _N [kW]				
	AJ	0,37			
			
	KP	160			
29	Number of motor poles				
	2	2 poles			
	4	4 poles			
	6	6 poles			
30	Scope of supply				
	A	Bare-shaft pump			
	C	Pump, baseplate			
	G	Back pull-out unit			
	H	Pump, motor			
31	Accessories/automation				
	A	KSB PumpDrive 2			
	B	KSB PumpMeter			
	C	KSB PumpDrive 2 + KSB PumpMeter			
	D	KSB MyFlow			
	E	KSB Guard			
	H	None			
	I	Version for potentially explosive atmospheres			

Position	Code	Description
31	J	KSB PumpDrive 2 + KSB Guard
	K	KSB PumpMeter 2 + KSB Guard
	L	KSB PumpDrive 2 + KSB PumpMeter + KSB Guard
	M	KSB MyFlow + KSB Guard
	N	KSB PumpDrive 3
	O	KSB PumpDrive R + KSB PumpMeter
	P	KSB PumpDrive R + KSB Guard
	Q	KSB PumpDrive R + KSB PumpMeter + KSB Guard
	R	KSB PumpDrive R
	W	KSB PumpDrive 3 + KSB Guard
32	Product generation	
	B	Generation B

Materials

Table 5: Symbols key

Symbol	Description
x	Standard
o	Optional
-	Version not available / not feasible

Table 6: Overview of available materials

Part No. (⇒ Page 34)	Description	Material	Material variant							
			GG	GB	GC	BB	SG	SB	SC	CC
102	Volute casing	Grey cast iron EN-GJL-250 / A 48 CL 35 B	x	x	x	-	-	-	-	-
		Grey cast iron EN-GJL-250 / CATA-PHORESIS	o	o	o	-	-	-	-	-
		Bronze CC480K-GS / B30 C90700	-	-	-	x	-	-	-	-
		Nodular cast iron EN-GJS-400-15 / A536 GR 60-40-18	-	-	-	-	x	x	x	-
		Stainless steel 1.4408 / A743 GR CF8 M	-	-	-	-	-	-	-	x
161	Casing cover, conical	Grey cast iron EN-GJL-250 / A 48 CL 35 B	x	x	x	-	-	-	-	-
		Grey cast iron EN-GJL-250 / CATA-PHORESIS	o	o	o	-	-	-	-	-
		Bronze CC480K-GS / B30 C90700	-	-	-	x	-	-	-	-
		Nodular cast iron EN-GJS-400-15 / A536 Gr 60-40-18	-	-	-	-	x	x	x	-
		Stainless steel 1.4408 / A743 Gr CF8 M	-	-	-	-	-	-	-	x
161	Casing cover, cylindrical	Grey cast iron EN-GJL-250 / A 48 Cl. 35 B	o	o	o	-	-	-	-	-
		Grey cast iron EN-GJL-250 / CATA-PHORESIS	o	o	o	-	-	-	-	-
		Stainless steel 1.4408 / A743 Gr CF8 M	-	-	-	o	-	-	-	-
		Bronze CC480K-GS / B30 C90700	-	-	-	-	-	-	-	o
210	Shaft	Tempered steel C45+N	x	x	x	-	x	x	x	-
		Stainless steel 1.4571	o	o	o	x	o	o	o	x
230	Impeller	Grey cast iron EN-GJL-250 / A 48 CL 35 B	x	-	-	-	x	-	-	-
		Bronze CC480K-DW	-	x	-	x	-	x	-	-
		Stainless steel 1.4408 / A743 Gr CF8 M	-	-	x	-	-	-	x	x
341	Drive lantern	Grey cast iron EN-GJL-250 / A 48 CL 35 B	x	x	x	x	x	x	x	x
400	Gaskets	DPAF, asbestos-free	x	x	x	x	x	x	x	x
502.01	Casing wear ring, suction side	JL / lamellar graphite cast iron	x	x	x	-	x	x	x	-

Part No. (⇒ Page 34)	Description	Material	Material variant							
			GG	GB	GC	BB	SG	SB	SC	CC
502.01	Casing wear ring, suction side	Stainless steel (CrNiMo steel) ⁵⁾	o	o	o	-	-	-	-	o
		Bronze CC495K-GS	-	o	-	x	-	o	-	-
502.02	Casing wear ring, discharge side	JL / lamellar graphite cast iron	x	x	x	-	x	x	x	-
		Stainless steel (CrNiMo steel) ⁵⁾	o	o	o	-	-	-	-	o
		Bronze CC495K-GS	-	o	-	x	-	o	-	-
523	Shaft sleeve ⁶⁾	Stainless steel (CrNiMo steel) ⁵⁾	x	x	x	x	x	x	x	
902	Studs	Steel 8.8	x	x	x	-	x	x	x	-
		A4-70/ A193 Gr. B8M CL2	o	o	o	x	o	o	o	x
903	Screw plug	Steel	x	x	x	-	x	x	x	-
		A4/ AISI 316	o	o	o	x	o	o	o	x
920	Nut	8+A2A/ 8+B633 SC1 TP3	x	x	x	-	x	x	x	-
		A4/ AISI 316	o	o	o	x	o	o	o	x
920.95	Impeller nut	A4/ AISI 316	o	o	x	x	o	x	x	x
		Steel 8	x	x	-	-	x	-	-	-

Coating and preservation

- Coating and preservation to KSB standard

Product benefits

- Improved efficiency and NPSH_{req} by experimentally verified hydraulic design of impellers (vanes)
- Operating costs reduced by trimming the nominal impeller diameter to match the specified duty point
- Little wear, low vibration levels and excellent smooth running characteristics thanks to good suction performance and virtually cavitation-free operation across a wide operating range
- Casing sealed reliably – even in varying operating conditions – by confined casing gasket
- Large variety of materials as standard for perfectly matching the pump to the fluid handled
- Extended selection chart with additional pump sizes for small flow rates
- Easy to dismantle using forcing screws at the interface of casing cover and drive lantern

- Product's type and size identifier: see data sheet
- Hydraulic pump efficiency (%) with trimmed impeller: see data sheet
- Pump performance curves, including efficiency characteristics: see documented characteristic curve
- The efficiency of a pump with a trimmed impeller is usually lower than that of a pump with the full impeller diameter. Trimming of the impeller will adapt the pump to a fixed duty point, leading to reduced energy consumption. The minimum efficiency index (MEI) is based on the full impeller diameter.
- Operation of this water pump with variable duty points may be more efficient and economic when controlled, for example, by the use of a variable speed drive that matches the pump duty to the system.
- Information relevant for disassembly, recycling or disposal at end of life: see installation/operating manual
- Information on benchmark efficiency or benchmark efficiency graph for MEI = 0.70 (0.40) for the pump based on the model shown in the Figure are available at: www.europump.org/efficiencycharts

Product information

Product information as per Regulation No. 1907/2006 (REACH)

For information as per European chemicals regulation (EC) No. 1907/2006 (REACH) see <https://www.ksb.com/en-global/company/corporate-responsibility/reach>.

Product information as per Regulation No. 547/2012 (for water pumps with a maximum shaft power of 150 kW) implementing "Ecodesign" Directive 2009/125/EC

- Minimum efficiency index: see data sheet
- The benchmark for the most efficient water pumps is MEI ≥ 0.70.
- Year of construction: see data sheet
- Manufacturer's name or trade mark, commercial registration number and place of manufacture: see data sheet or order documentation

Acceptance tests and warranty

Materials inspection and testing:

- Test report 2.2 on request

Final inspection:

- Inspection certificate 3.1 to EN 10204 on request

Hydraulic test against surcharge

- Duty point to ISO 9906/2B
- NPSH test

Other inspections/tests on request

Warranty:

- Warranties are given within the scope of the valid terms and conditions of sale and delivery.

⁵⁾ Possible materials for material group CrNiMo steel INT (material identification code 7605): 1.4401, 1.4404, 1.4408, 1.4571, AISI 316, AISI 316Ti, A743 Gr. CF8 M, A479 type 316L.

⁶⁾ For versions with mechanical seal

Overview of product features / selection tables

Overview of variants

 Other designs on request

Table 7: Symbols key

Symbol	Description
X	Standard
-	Version not available / not feasible

Table 8: Overview of Etabloc variants

Variant	102 / Volute casing	230 / Impeller	Mechanical seal	T [°C]	Main applications									
					Handling clean or aggressive fluids not chemically and mechanically aggressive to the pump materials	Water supply systems	Cooling circuits	Swimming pools	Fire-fighting systems	General irrigation systems	Drainage systems	Heating systems	Air-conditioning systems	Spray irrigation systems
GG10	Grey cast iron EN-GJL-250 / A 48 Cl. 35 B	Grey cast iron EN-GJL-250 / A 48 Cl. 35 B	Mech. seal QXGG	≥ -20 - ≤ +110	-	X	-	X ⁷⁾	X	X	X	-	-	X
GG11	Grey cast iron EN-GJL-250 / A 48 Cl. 35 B	Grey cast iron EN-GJL-250 / A 48 Cl. 35 B	Mech. seal BQEGG DW001	≥ -30 - ≤ +110	X	X	X ⁸⁾	-	X	-	-	-	X ⁸⁾	-
GG76	Grey cast iron EN-GJL-250 / A 48 Cl. 35 B	Grey cast iron EN-GJL-250 / A 48 Cl. 35 B	SU 25, 35: mech. seal AQ7EGG-Y10 SU 55: mech. seal AQ1EGG	≥ -30 - ≤ +140	-	-	-	-	-	-	-	X	-	-
GB10	Grey cast iron EN-GJL-250 / A 48 Cl. 35 B	Bronze CC480K-DW / B30 C90700	Mech. seal QXGG	≥ -20 - ≤ +110	-	X	-	X ⁷⁾	X	X	X	-	-	X
GB11	Grey cast iron EN-GJL-250 / A 48 Cl. 35 B	Bronze CC480K-DW / B30 C90700	Mech. seal BQEGG DW001	≥ -30 - ≤ +110	X	X	X ⁸⁾	-	X	-	-	-	X ⁸⁾	-
GB76	Grey cast iron EN-GJL-250 / A 48 Cl. 35 B	Bronze CC480K-DW / B30 C90700	SU 25, 35: mech. seal AQ7EGG-Y10 SU 55: mech. seal AQ1EGG	≥ -30 - ≤ +140	-	-	-	-	-	-	-	X	-	-
CC10	Stainless steel 1.4408 / A743 Gr. CF8 M	Stainless steel 1.4408 / A743 Gr. CF8 M	Mech. seal QXGG	≥ -20 - ≤ +110	-	X	-	X ⁷⁾	X	X	X	-	-	X
CC11	Stainless steel 1.4408 / A743 Gr. CF8 M	Stainless steel 1.4408 / A743 Gr. CF8 M	Mech. seal BQEGG DW001	≥ -30 - ≤ +110	X	X	X ⁸⁾	-	X	-	-	-	X ⁸⁾	-
CC76	Stainless steel 1.4408 / A743 Gr. CF8 M	Stainless steel 1.4408 / A743 Gr. CF8 M	SU 25, 35: mech. seal AQ7EGG-Y10 SU 55: mech. seal AQ1EGG	≥ -30 - ≤ +140	-	-	-	-	-	-	-	X	-	-

⁷ QXGG

⁸ QEGG, fluid handled: water, glycol with inhibitors

Overview of fluids handled
Table 9: Symbols key

Symbol	Description
X	Standard
-	Version not available / not feasible

Table 10: Excerpt from the overview of fluids handled with associated material variants

Fluid handled	T ⁹⁾		Materials					Shaft seal					Comments
	Minimum	Maximum	Casing/impeller					Mechanical seal					
			Grey cast iron/ grey cast iron	Grey cast iron/ tin bronze	Nodular cast iron/ grey cast iron	Tin bronze/ tin bronze	CrNiMo cast steel/ CrNiMo cast steel	QQEGG	Q7Q7VGG-Y10	QQXGG	BQEGG DW001	Q12Q1M1GG1	
[°C]		GG	GB	SG	BB	CC	7	79	10	11	12		
Water													
Brackish water ¹⁰⁾	-	≤ +25	-	-	-	X	-	-	-	X	-	-	CrNiMo cast steel can be used.
Fire-fighting water ¹¹⁾	-	≤ +60	-	X	-	-	-	-	-	X	-	-	Contact the manufacturer for supply to VdS guideline.
Heating water ¹²⁾	-	≤ +110	X	-	-	-	-	-	-	-	X	-	If used as a circulating pump to DIN 4752: p maximum ≤ 10 bar. If ductile material has been specified: SG
Condensate, conditioned	-	≤ +110	X	-	-	-	-	-	-	-	X	-	-
Condensate, not conditioned	-	≤ +110	-	-	-	-	X	-	-	-	-	X	-
Cooling water without antifreeze	-	≤ +60	X	-	-	-	-	-	-	X	-	-	Open circuit: GB 10 required
Cooling water with antifreeze ¹³⁾ , pH ≥ 7.5	≥ -30	≤ +60	X	-	-	-	-	-	-	-	X	-	Open circuit: BB 66 or CC 66 required
Cooling water with antifreeze ¹³⁾ , pH ≥ 7.5	≥ +60	≤ +110	X	-	-	-	-	X	-	-	-	-	Open circuit: BB 66 or CC 66 required
Slightly contaminated water	-	≤ +60	X	-	-	-	-	-	-	X	-	-	-
Seawater	-	≤ +25	-	-	-	X	-	-	-	X	-	-	CrNiMo cast steel can be used.
Pure water ¹⁴⁾	-	≤ +60	X	-	-	-	-	-	-	-	X	-	-
Raw water	-	≤ +60	X	-	-	-	-	-	-	X	-	-	-
Swimming pool water (fresh water)	-	≤ +60	X	-	-	-	-	-	-	X	-	-	Also applies to requirements as per DIN 19643
Swimming pool water ¹⁵⁾ : filtration	-	≤ +40	-	X	-	-	-	-	-	X	-	-	Variant GB Shaft C45+N, shaft sleeve CrNiMo steel, nut A4/AISI 316, key A2, casing wear ring (suction and discharge side) grey cast iron JL 1040/ CI
Swimming pool water ¹⁵⁾ : water features; without turbulences and/or air content	-	≤ +40	-	X	-	-	-	-	-	X	-	-	Variant GB Shaft C45+N, shaft sleeve CrNiMo steel, nut A4/ AISI 316, key A2, casing wear ring (suction and discharge side) CC495K-GS
Swimming pool water ¹⁵⁾ : water features; with turbulences and/or air content	-	≤ +40	-	-	-	X	-	-	-	X	-	-	Variant B Shaft 1.4571, shaft sleeve CrNiMo steel, nut A4/ AISI 316, key A2, casing wear ring (suction and discharge side) CC495K-GS
Swimming pool water (seawater)	-	≤ +40	-	-	-	X	-	-	-	X	-	-	CrNiMo cast steel for t ≤ 25 °C
Dam water	-	≤ +60	-	X	-	-	-	-	-	X	-	-	If solids are contained, contact the manufacturer.
Drinking water ¹⁶⁾	-	≤ +60	-	X	-	-	-	-	-	-	X	-	-
Partly desalinated water	-	≤ +110	X	-	-	X	-	-	-	-	X	-	-

⁹⁾ T = fluid temperature

¹⁰⁾ For components made of bronze: ammonia (NH₃) ≤ 5 mg/kg, free from hydrogen sulphide (H₂S); no limitation of Cl content required in this case. Please contact the manufacturer if limits are exceeded.

¹¹⁾ General evaluation criteria for results of water analysis: pH ≥ 7; chlorides content (Cl) ≤ 250 mg/kg. Chlorine (Cl₂) ≤ 0.6 mg/kg

¹²⁾ Treatment to VdTUV 1466, additional requirement: O₂ t ≤ 0.02 mg/l

¹³⁾ Antifreeze on ethylene glycol basis with inhibitors, content > 20 % to 50 % (e.g. Antifrogen N)

¹⁴⁾ No ultra-pure water. Conductivity at 25 °C: ≤ 800 µS/cm, neutral with regard to chemical corrosion

¹⁵⁾ For France, observe the applicable rules as per ministerial order dated 18 January 2002.

¹⁶⁾ For France, ACS approval is required.

Fluid handled	T ⁹⁾		Materials					Shaft seal					Comments
	Minimum	Maximum	Casing/impeller					Mechanical seal					
			Grey cast iron/ grey cast iron	Grey cast iron/ tin bronze	Nodular cast iron/ grey cast iron	Tin bronze/ tin bronze	CrNiMo cast steel/ CrNiMo cast steel	QQEGG	Q7Q7VGG-Y10	QQXGG	BQEGG DW001	Q12Q1M1GG1	
[°C]		GG	GB	SG	BB	CC	7	79	10	11	12		
Fully desalinated water	-	≤ +110	-	-	-	X	X	-	-	-	X	-	Purity requirements cannot be met.
Fully desalinated water as boiler feed water	-	≤ +110	X	-	-	-	-	-	-	-	X	-	-
Refrigerants, cooling brines													
Cooling brine; inorganic, pH > 7.5, inhibited	≥ -30	≤ +25	X	-	-	-	-	-	-	-	X	-	-
Water with antifreeze, pH ≥ 7.5	≥ -30	≤ +60	X	-	-	-	-	-	-	-	X	-	-
Water with antifreeze, pH ≥ 7.5	≥ +60	≤ +110	X	-	-	-	-	X	-	-	-	-	-
Oils/emulsions													
Diesel fuel, extra light fuel oil	-	≤ +60	-	-	X	-	-	-	-	X	-	-	GG possible, unless specific standards have to be observed
Lubricating oil, turbine oil (does not apply to SF-D oils, hardly flammable)	-	≤ +80	-	-	X	-	-	-	-	X	-	-	For versions without internal primer contact the manufacturer. GG possible, unless specific standards have to be observed
Drilling emulsion, grinding emulsion	-	≤ +60	X	-	-	-	-	-	X	-	-	-	-
Oil-water emulsion	-	≤ +60	X	-	-	-	-	-	X	-	-	-	-
Brewery applications													
Beer mash	-	≤ +100	X	-	-	-	-	-	-	-	-	X	If there is a risk of the pump running dry due to excessive emptying of the tank, use an Etanorm with double mechanical seal in tandem arrangement.
Beer wort	-	≤ +100	X	-	-	-	-	-	-	-	-	X	

Overview of materials

Table 11: Symbols key

Symbol	Description
X	Standard
-	Version not available / not feasible

Table 12: Material variants available

Size	GG	GB	GC	BB	SG	SB	SC	CC
040-025-160	X	X	X	-	X	X	X	X
040-025-200	X	X	X	-	X	X	X	X
050-032-125.1	X	X	X	X	X	X	X	X
050-032-160.1	X	X	X	X	X	X	X	X
050-032-200.1	X	X	X	X	X	X	X	X
050-032-250.1	X	X	X	-	-	-	-	X
050-032-125	X	X	X	X	-	-	-	X
050-032-160	X	X	X	X	X	X	X	X
050-032-200	X	X	X	X	X	X	X	X
050-032-250	X	X	X	-	X	X	X	X
065-040-125	X	X	X	X	-	-	-	X
065-040-160	X	X	X	X	X	X	X	X
065-040-200	X	X	X	X	X	X	X	X
065-040-250	X	X	X	X	X	X	X	X
065-040-315	X	X	X	-	X	X	X	X
065-050-125	X	X	X	X	-	-	-	X
065-050-160	X	X	X	X	X	X	X	X
065-050-200	X	X	X	X	X	X	X	X
065-050-250	X	X	X	X	X	X	X	X
065-050-315	X	X	X	-	X	X	X	X
080-065-125	X	X	X	X	-	-	-	X
080-065-160	X	X	X	X	X	X	X	X
080-065-200	X	X	X	X	X	X	X	X
080-065-250	X	X	X	X	X	X	X	X
080-065-315	X	X	X	X	X	X	X	X
100-080-160	X	X	X	X	X	X	X	X
100-080-200	X	X	X	X	X	X	X	X
100-080-250	X	X	X	X	X	X	X	X
100-080-315	X	X	X	-	X	X	X	X
100-080-400	X	X	X	-	-	-	-	X
125-100-160	X	X	X	X	X	X	X	X
125-100-200	X	X	X	X	X	X	X	X
125-100-250	X	X	X	X	X	X	X	X
125-100-315	X	X	X	X	X	X	X	X
125-100-400	X	X	X	-	-	-	-	X
150-125-200	X	X	X	X	X	X	X	X
150-125-250	X	X	X	X	X	X	X	X
150-125-315	X	X	X	X	X	X	X	X
150-125-400	X	X	X	-	X	X	X	X
200-150-200	X	X	X	-	-	-	-	X
200-150-250	X	X	X	X	-	-	-	X
200-150-315	X	X	X	X	X	X	X	X
200-150-400	X	X	X	X	X	X	X	X

Overview of pump size / motor combinations

Table 13: Symbols key

Symbol	Description
X	Standard
-	Version not available / not feasible

Table 14: Available pump size / motor combinations

Size	n			Motor (IEC)												
	2900 / 3500	1450 / 1750	960 / 1160	71	80	90	100	112	132	160	180	200	225	250	280	315
	[rpm]	[rpm]	[rpm]													
040-025-160	X	-	-	-	X	X	X	X	X	-	-	-	-	-	-	-
040-025-160	-	X	-	X	X	X	-	-	-	-	-	-	-	-	-	-
040-025-160	-	-	X	-	X	X	-	-	-	-	-	-	-	-	-	-
040-025-200	X	-	-	-	-	X	X	X	X	X	-	-	-	-	-	-
040-025-200	-	X	-	X	X	X	X	-	-	-	-	-	-	-	-	-
040-025-200	-	-	X	-	X	X	-	-	-	-	-	-	-	-	-	-
050-032-125.1	X	-	-	X	X	X	X	X	X	-	-	-	-	-	-	-
050-032-125.1	-	X	-	X	X	X	-	-	-	-	-	-	-	-	-	-
050-032-125.1	-	-	X	-	X	X	-	-	-	-	-	-	-	-	-	-
050-032-160.1	X	-	-	-	X	X	X	X	X	X	-	-	-	-	-	-
050-032-160.1	-	X	-	X	X	X	-	-	-	-	-	-	-	-	-	-
050-032-160.1	-	-	X	-	X	X	-	-	-	-	-	-	-	-	-	-
050-032-200.1	X	-	-	-	-	X	X	X	X	X	-	-	-	-	-	-
050-032-200.1	-	X	-	X	X	X	X	-	-	-	-	-	-	-	-	-
050-032-200.1	-	-	X	-	X	X	-	-	-	-	-	-	-	-	-	-
050-032-250.1	X	-	-	-	-	-	-	X	X	X	X	-	-	-	-	-
050-032-250.1	-	X	-	-	X	X	X	X	X	-	-	-	-	-	-	-
050-032-250.1	-	-	X	-	X	X	-	-	-	-	-	-	-	-	-	-
050-032-125	X	-	-	-	X	X	X	X	X	-	-	-	-	-	-	-
050-032-125	-	X	-	X	X	X	-	-	-	-	-	-	-	-	-	-
050-032-125	-	-	X	-	X	X	-	-	-	-	-	-	-	-	-	-
050-032-160	X	-	-	-	-	X	X	X	X	X	-	-	-	-	-	-
050-032-160	-	X	-	X	X	X	X	-	-	-	-	-	-	-	-	-
050-032-160	-	-	X	-	X	X	-	-	-	-	-	-	-	-	-	-
050-032-200	X	-	-	-	-	-	X	X	X	X	X	-	-	-	-	-
050-032-200	-	X	-	X	X	X	X	X	-	-	-	-	-	-	-	-
050-032-200	-	-	X	-	X	X	-	-	-	-	-	-	-	-	-	-
050-032-250	X	-	-	-	-	-	-	-	X	X	X	X	-	-	-	-
050-032-250	-	X	-	-	X	X	X	X	X	-	-	-	-	-	-	-

Size	n			Motor (IEC)												
	2900 / 3500	1450 / 1750	960 / 1160	71	80	90	100	112	132	160	180	200	225	250	280	315
	[rpm]	[rpm]	[rpm]													
050-032-250	-	-	X	-	X	X	-	-	-	-	-	-	-	-	-	-
065-040-125	X	-	-	-	-	X	X	X	X	X	-	-	-	-	-	-
065-040-125	-	X	-	X	X	X	-	-	-	-	-	-	-	-	-	-
065-040-125	-	-	X	-	X	X	-	-	-	-	-	-	-	-	-	-
065-040-160	X	-	-	-	-	-	X	X	X	X	X	-	-	-	-	-
065-040-160	-	X	-	X	X	X	X	X	-	-	-	-	-	-	-	-
065-040-160	-	-	X	-	X	X	-	-	-	-	-	-	-	-	-	-
065-040-200	X	-	-	-	-	-	-	X	X	X	X	X	-	-	-	-
065-040-200	-	X	-	-	X	X	X	X	X	-	-	-	-	-	-	-
065-040-200	-	-	X	-	X	X	-	-	-	-	-	-	-	-	-	-
065-040-250	X	-	-	-	-	-	-	-	X	X	X	X	-	-	-	-
065-040-250	-	X	-	-	X	X	X	X	X	X	-	-	-	-	-	-
065-040-250	-	-	X	-	X	X	X	-	-	-	-	-	-	-	-	-
065-040-315	X	-	-	-	-	-	-	-	-	X	X	X	X	X	-	-
065-040-315	-	X	-	-	-	-	X	X	X	X	X	-	-	-	-	-
065-040-315	-	-	X	-	-	-	X	X	X	-	-	-	-	-	-	-
065-050-125	X	-	-	-	-	X	X	X	X	X	X	-	-	-	-	-
065-050-125	-	X	-	X	X	X	X	-	-	-	-	-	-	-	-	-
065-050-125	-	-	X	-	X	X	-	-	-	-	-	-	-	-	-	-
065-050-160	X	-	-	-	-	-	-	X	X	X	X	X	-	-	-	-
065-050-160	-	X	-	-	X	X	X	X	X	-	-	-	-	-	-	-
065-050-160	-	-	X	-	X	X	-	-	-	-	-	-	-	-	-	-
065-050-200	X	-	-	-	-	-	-	-	X	X	X	X	-	-	-	-
065-050-200	-	X	-	-	X	X	X	X	X	X	-	-	-	-	-	-
065-050-200	-	-	X	-	X	X	X	-	-	-	-	-	-	-	-	-
065-050-250	X	-	-	-	-	-	-	-	-	X	X	X	-	-	-	-
065-050-250	-	X	-	-	-	X	X	X	X	X	-	-	-	-	-	-
065-050-250	-	-	X	-	X	X	X	X	-	-	-	-	-	-	-	-
065-050-315	X	-	-	-	-	-	-	-	-	-	X	X	X	X	X	-
065-050-315	-	X	-	-	-	-	X	X	X	X	X	X	-	-	-	-
065-050-315	-	-	X	-	-	-	X	X	X	-	-	-	-	-	-	-
080-065-125	X	-	-	-	-	-	X	X	X	X	X	X	-	-	-	-
080-065-125	-	X	-	X	X	X	X	X	-	-	-	-	-	-	-	-
080-065-125	-	-	X	-	X	X	-	-	-	-	-	-	-	-	-	-
080-065-160	X	-	-	-	-	-	-	X	X	X	X	X	-	-	-	-
080-065-160	-	X	-	-	X	X	X	X	X	-	-	-	-	-	-	-
080-065-160	-	-	X	-	X	X	-	-	-	-	-	-	-	-	-	-

Size	n			Motor (IEC)												
	2900 / 3500	1450 / 1750	960 / 1160	71	80	90	100	112	132	160	180	200	225	250	280	315
	[rpm]	[rpm]	[rpm]													
080-065-200	X	-	-	-	-	-	-	-	X	X	X	X	-	-	-	-
080-065-200	-	X	-	-	-	X	X	X	X	X	-	-	-	-	-	-
080-065-200	-	-	X	-	X	X	X	X	-	-	-	-	-	-	-	-
080-065-250	X	-	-	-	-	-	-	-	-	X	X	X	X	X	X	X
080-065-250	-	X	-	-	-	-	X	X	X	X	X	-	-	-	-	-
080-065-250	-	-	X	-	-	-	X	X	X	-	-	-	-	-	-	-
080-065-315	X	-	-	-	-	-	-	-	-	-	-	X	X	X	X	X
080-065-315	-	X	-	-	-	-	X	X	X	X	X	X	-	-	-	-
080-065-315	-	-	X	-	-	-	-	X	X	-	-	-	-	-	-	-
100-080-160	X	-	-	-	-	-	-	-	X	X	X	X	-	-	-	-
100-080-160	-	X	-	-	X	X	X	X	X	X	-	-	-	-	-	-
100-080-160	-	-	X	-	X	X	X	-	-	-	-	-	-	-	-	-
100-080-200	X	-	-	-	-	-	-	-	-	X	X	X	X	X	X	-
100-080-200	-	X	-	-	-	-	X	X	X	X	X	-	-	-	-	-
100-080-200	-	-	X	-	-	-	X	X	X	-	-	-	-	-	-	-
100-080-250	X	-	-	-	-	-	-	-	-	-	X	X	X	X	X	X
100-080-250	-	X	-	-	-	-	X	X	X	X	X	X	-	-	-	-
100-080-250	-	-	X	-	-	-	X	X	X	-	-	-	-	-	-	-
100-080-315	X	-	-	-	-	-	-	-	-	-	-	-	X	X	X	X
100-080-315	-	X	-	-	-	-	-	-	X	X	X	X	X	-	-	-
100-080-315	-	-	X	-	-	-	-	-	X	X	-	-	-	-	-	-
100-080-400	-	X	-	-	-	-	-	-	-	-	X	X	X	X	X	-
125-100-160	X	-	-	-	-	-	-	-	-	X	X	X	X	X	X	-
125-100-160	-	X	-	-	-	-	X	X	X	X	-	-	-	-	-	-
125-100-160	-	-	X	-	-	-	X	X	-	-	-	-	-	-	-	-
125-100-200	X	-	-	-	-	-	-	-	-	-	X	X	X	X	X	X
125-100-200	-	X	-	-	-	-	X	X	X	X	X	X	-	-	-	-
125-100-200	-	-	X	-	-	-	X	X	X	-	-	-	-	-	-	-
125-100-250	X	-	-	-	-	-	-	-	-	-	-	X	X	X	X	X
125-100-250	-	X	-	-	-	-	-	X	X	X	X	X	X	-	-	-
125-100-250	-	-	X	-	-	-	-	X	X	X	-	-	-	-	-	-
125-100-315	-	X	-	-	-	-	-	-	X	X	X	X	X	-	-	-
125-100-315	-	-	X	-	-	-	-	-	X	X	-	-	-	-	-	-
125-100-400	-	X	-	-	-	-	-	-	-	-	X	X	X	X	X	X
150-125-200	X	-	-	-	-	-	-	-	-	-	-	X	X	X	X	X
150-125-200	-	X	-	-	-	-	X	X	X	X	X	X	X	-	-	-
150-125-200	-	-	X	-	-	-	-	X	X	-	-	-	-	-	-	-

Size	n			Motor (IEC)												
	2900 / 3500	1450 / 1750	960 / 1160	71	80	90	100	112	132	160	180	200	225	250	280	315
	[rpm]	[rpm]	[rpm]													
150-125-250	-	X	-	-	-	-	-	-	X	X	X	X	X	-	-	-
150-125-250	-	-	X	-	-	-	-	-	X	X	-	-	-	-	-	-
150-125-315	-	X	-	-	-	-	-	-	-	-	X	X	X	X	X	-
150-125-400	-	X	-	-	-	-	-	-	-	-	X	X	X	X	X	X
200-150-200	-	X	-	-	-	-	-	X	X	X	X	X	X	-	-	-
200-150-200	-	-	X	-	-	-	-	-	X	X	-	-	-	-	-	-
200-150-250	-	X	-	-	-	-	-	-	X	X	X	X	X	-	-	-
200-150-250	-	-	X	-	-	-	-	-	X	X	X	-	-	-	-	-
200-150-315	-	X	-	-	-	-	-	-	-	-	X	X	X	X	X	X
200-150-400	-	X	-	-	-	-	-	-	-	-	X	X	X	X	X	X

Overview of functions for variable speed version
Table 15: Overview of functions

Functions / firmware	PumpDrive 2	PumpDrive 2 Eco
Protective functions		
Thermal motor protection	X	X
Mains voltage monitoring	X	X
Phase failure, motor side	X	X
Short-circuit monitoring, motor side (phase to phase and phase to earth)	X	X
Dynamic overload protection by speed limitation (i ² t control)	X	X
Resonant frequency suppression	X	X
Broken wire detection (live zero)	X	X
Protection against dry running and hydraulic blockage (sensorless due to learning function)	X	X
Dry running protection (external control signal)	X	X
Operating point estimation and characteristic curve control	X	X
Open-loop control		
Open-loop control mode	X	X
Closed-loop control		
Closed-loop control mode via integrated PID controller	X	X
Pressure control / differential pressure control (Δp const)	X	X
Pressure control / differential pressure control with dynamic pressure compensation (Δp var)	X	X
Flow rate control	X	X
Sensorless differential pressure control (Δp const) in a single-pump configuration	X	X
Sensorless differential pressure control with dynamic pressure compensation (Δp var) in a single-pump configuration	X	X
Sensorless flow rate control	X	X
Level control	X	X
Temperature control	X	X
Alternative setpoint	X	-
Operation and monitoring (display)		
Measured value display (pressure, head, speed, electric power, motor voltage, motor current, torque)	X	X
Fault history	X	X
Operating hours counter	X	X
Fault reporting via relay	X	X
Frequency inverter functions		
Programmable start ramps and stop ramps	X	X
Field-oriented control (vector control), V/f control	X	X
Configurable motor control method (asynchronous motor, KSB SuPremE)	X	X
Automatic motor adaptation (AMA)	X	X
Motor standstill heater	X	X
Manual-0-automatic mode	X	X
External OFF	X	X
External minimum speed	X	X
Sleep mode (stand-by mode)	X	X
Energy savings meter	X	-
Pump functions		
Flow rate estimation	X	X
M12 module with PumpMeter bus connection	X	X
M12 module for dual-pump configuration	X	X
M12 module for multiple pump configuration with up to 6 pumps	X	X
Functional check run	X	X
Deragging	X	X
Integrated dual-pump configuration (1x100 % with redundant pump or 2x50 % without redundant pump)	X	X
Multiple pump configuration with up to 6 pumps	X	X
Waste water function: start-up at maximum speed	X	-
Waste water function: rinsing function	X	-
Operation		

Functions / firmware	PumpDrive 2	PumpDrive 2 Eco
Control panel	X	X ¹⁷⁾
Commissioning wizard	X	X ¹⁸⁾
Favourites list	X	-
Service interface	X	X

Pressure limits and temperature limits

Test pressure limits and temperature limits

Table 16: Pressure limits and temperature limits as a function of material variant

Material variant	Fluid temperature ¹⁹⁾²⁰⁾	Test pressure ²¹⁾
	[°C]	[bar]
GG, GC	-30 to +140	21
GB	-30 to +140	21
SG, SB, SC	-30 to +140	25
BB	-30 to +140	15
CC	-30 to +140	21

In-service pressure limits and temperature limits

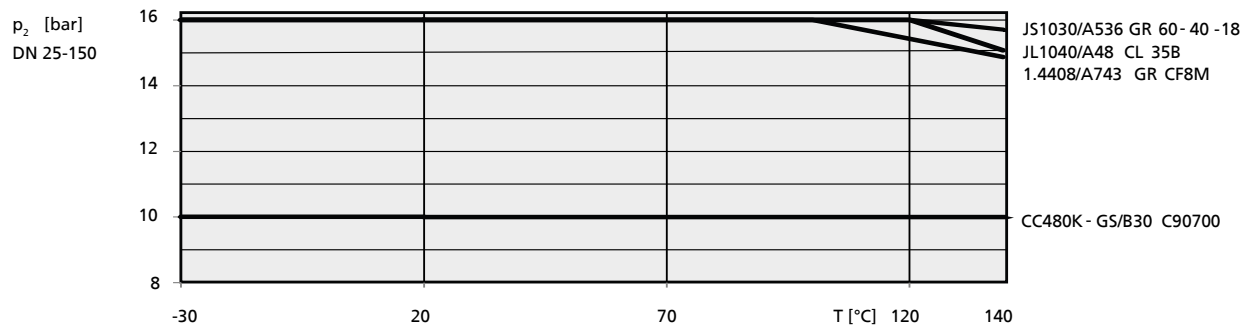

Fig. 1: Pump pressure limits and temperature limits DN 25 - DN 150

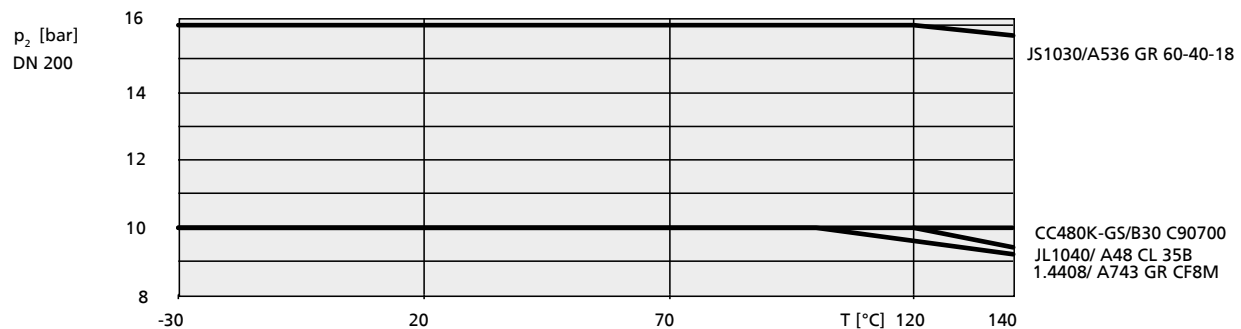

Fig. 2: Pump pressure limits and temperature limits DN 200

¹⁷ Some functions can only be parameterised and/or displayed using the KSB ServiceTool (see operating manual).
¹⁸ Only available via KSB ServiceTool or app
¹⁹ For hot water heating systems to DIN 4752, Section 4.5, application limits must be observed.
²⁰ For fluid temperatures >140 °C use Etanorm SYT.
²¹ The casing components have been checked for leakage by means of internal pressure tests to ZN 1650 with water.

Technical data
Etabloc
Table 17: Technical data

Size	Shaft unit	Impeller					Speed limit	
		Impeller outlet width	Free pas-sage	Impeller inlet dia-meter	Nominal impeller diameter		Maximum	Minimum
					Maximum	Minimum		
[mm]						[rpm]		
040-025-160	WS_25	6,0	5,7	45,2	169	135	3600	500
040-025-200	WS_25	6,0	5,7	45,2	209	165	3600	500
050-032-125.1	WS_25	6,8	6,0	52,4	139	104	3600	500
050-032-160.1	WS_25	5,7	5,4	52,7	170	135	4400	500
050-032-200.1	WS_25	5,6	5,3	54,0	204	168	3800	500
050-032-250.1	WS_25	5,5	5,2	58,3	254	200	3600	500
050-032-125	WS_25	9,8	5,7	63,4	139	104	3600	500
050-032-160	WS_25	8,5	5,8	60,6	174	132	3600	500
050-032-200	WS_25	7,0	6,7	62,9	209	170	3700	500
050-032-250	WS_25	7,5	7,1	62,6	261	205	3600	500
065-040-125	WS_25	14,0	9,6	73,9	139	104	3600	500
065-040-160	WS_25	13,0	11,5	70,0	174	128	4400	500
065-040-200	WS_25	9,4	8,9	69,4	209	160	3700	500
065-040-250	WS_25	8,4	8,0	74,1	260	195	3600	500
065-040-315	WS_35	7,5	7,1	75,3	326	260	3000	500
065-050-125	WS_25	19,9	11,6	87,9	142	112	4500	500
065-050-160	WS_25	16,9	11,6	86,9	174	128	4400	500
065-050-200	WS_25	13,8	11,9	83,6	219	170	3600	500
065-050-250	WS_25	10,5	10,0	84,0	260	215	3600	500
065-050-315	WS_35	10,0	9,5	87,0	323	265	3000	500
080-065-125	WS_25	25,8	12,9	99,0	141	109	3900	500
080-065-160	WS_25	21,0	12,2	91,9	174	132	3900	500
080-065-200	WS_25	17,0	13,3	99,7	219	165	3600	500
080-065-250	WS_35	15,1	14,3	101,0	260	215	3600	500
080-065-315	WS_35	13,7	14,0	108,2	320	245	3000	500
100-080-160	WS_25	31,6	15,1	124,0	174	138	3600	500
100-080-200	WS_35	24,5	15,2	115,3	219	165	3600	500
100-080-250	WS_35	19,0	15,8	115,1	269	215	3600	500
100-080-315	WS_35	18,7	17,8	115,6	334	265	3000	500
100-080-400	WS_55	15,0	14,3	129,9	398	315	1900	500
125-100-160	WS_35	37,6	16,4	135,4	185	162	3600	500
125-100-200	WS_35	32,5	17,9	142,0	219	170	3600	500
125-100-250	WS_35	27,0	18,8	145,0	269	210	3600	500
125-100-315	WS_35	23,0	19,9	142,1	334	250	3000	500
125-100-400	WS_55	18,0	17,1	142,8	401	317	1900	500
150-125-200	WS_35	40,7	21,1	159,2	224	182	3600	500
150-125-250	WS_35	37,0	22,4	162,4	269	218	2000	500
150-125-315	WS_55	30,9	22,6	162,3	334	270	1900	500
150-125-400	WS_55	25,9	20,9	162,4	419	330	1800	500
200-150-200	WS_35	59,5	25,2	179,4	224	188	2100	500
200-150-250	WS_35	48,8	23,0	191,0	269	220	1800	500
200-150-315	WS_55	39,7	26,9	191,5	334	264	1800	500
200-150-400	WS_55	33,0	23,8	191,4	419	330	1800	500

Selection charts

Etabloc, n = 2900 rpm (fixed speed version)

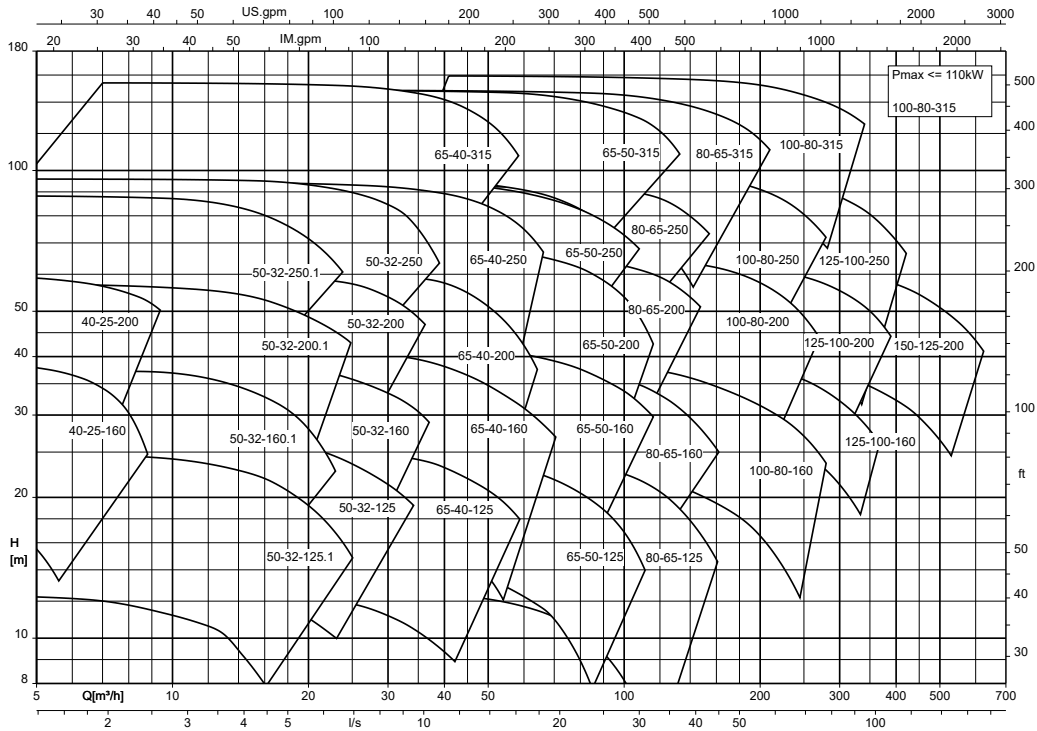

Etabloc, n = 1450 rpm (fixed speed version)

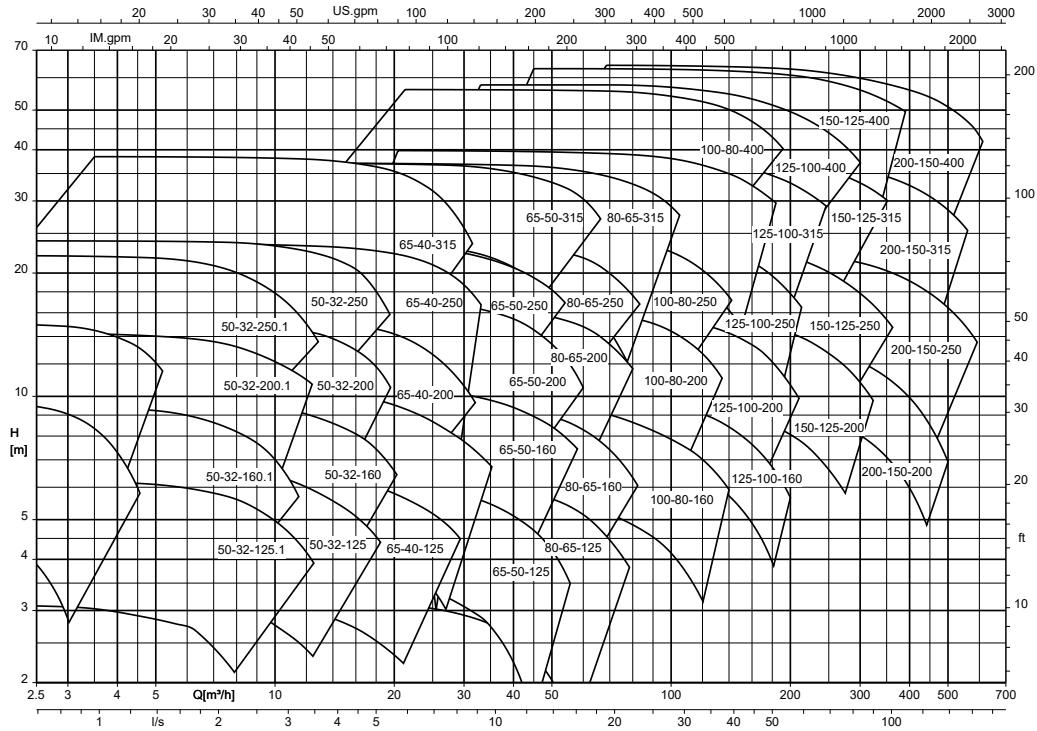

1173.5/09-EN

Etabloc, n = 960 rpm (fixed speed version)

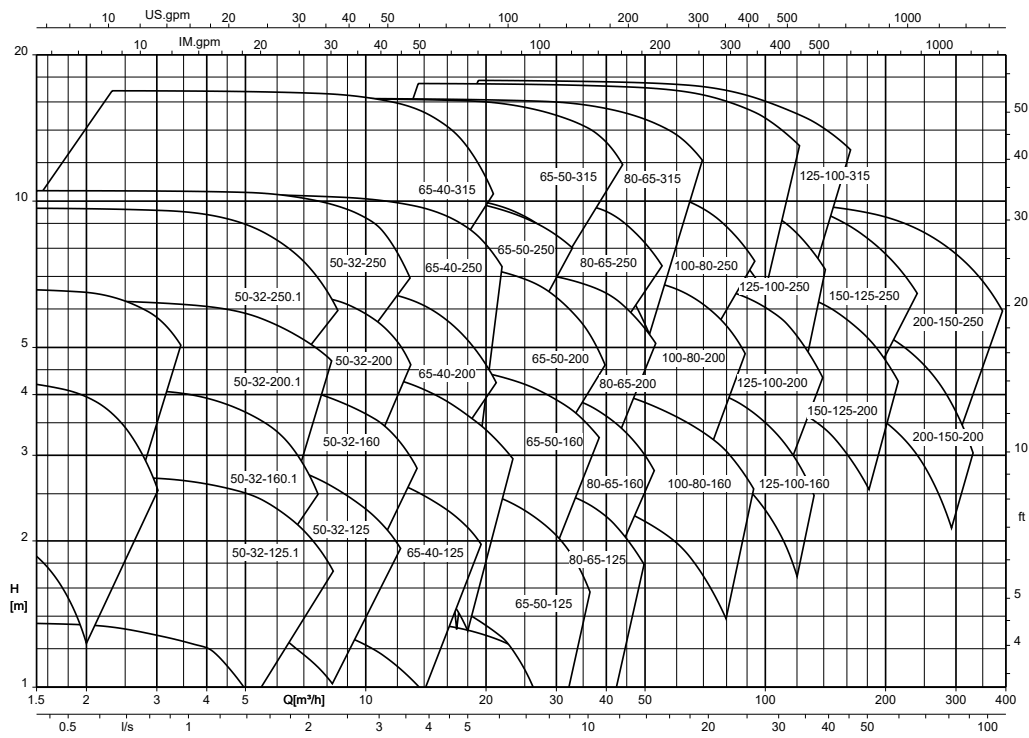

Etabloc, n = 3500 rpm (fixed speed version)

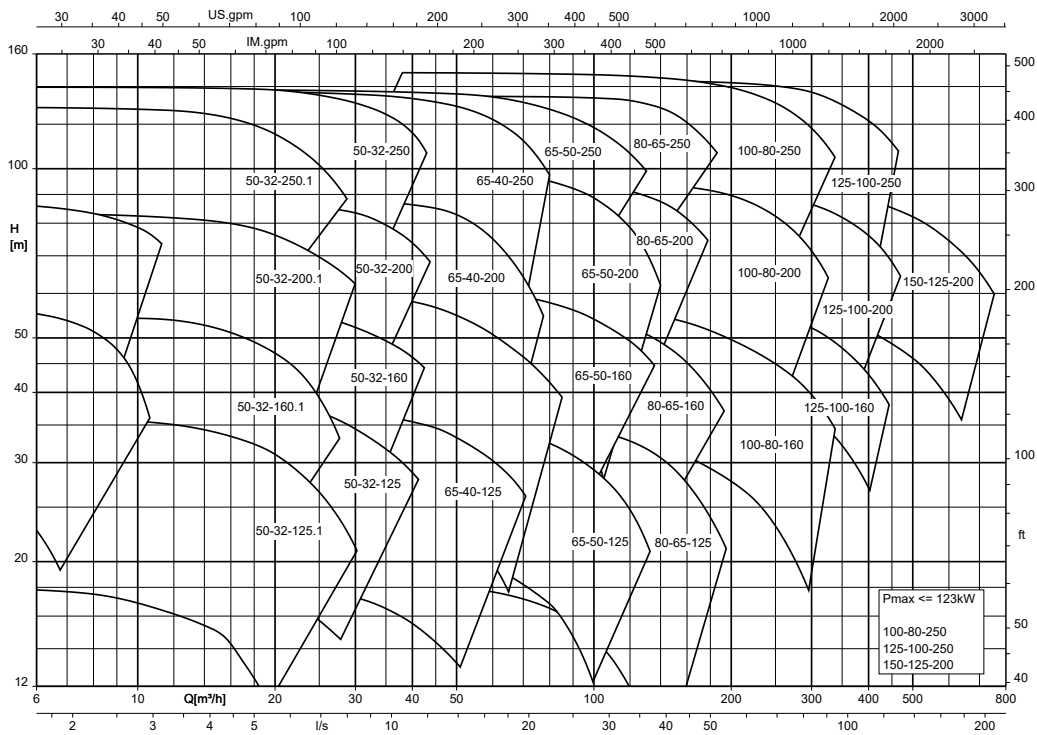

Etabloc, n = 1750 rpm (fixed speed version)

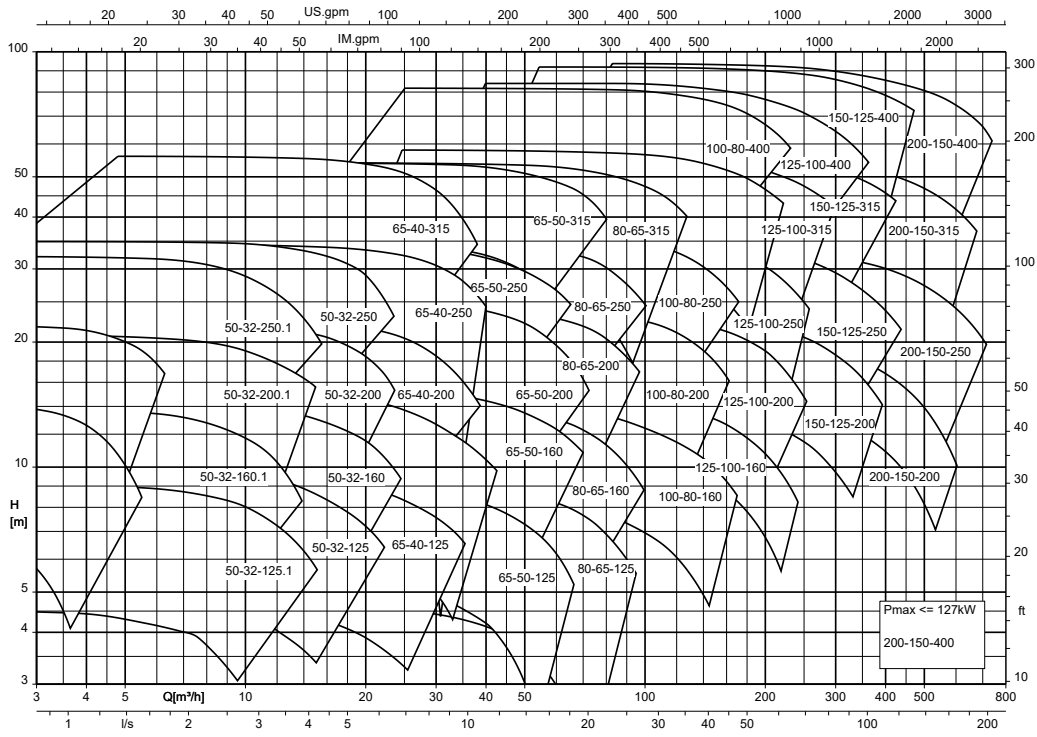

Etabloc, n = 1160 rpm (fixed speed version)

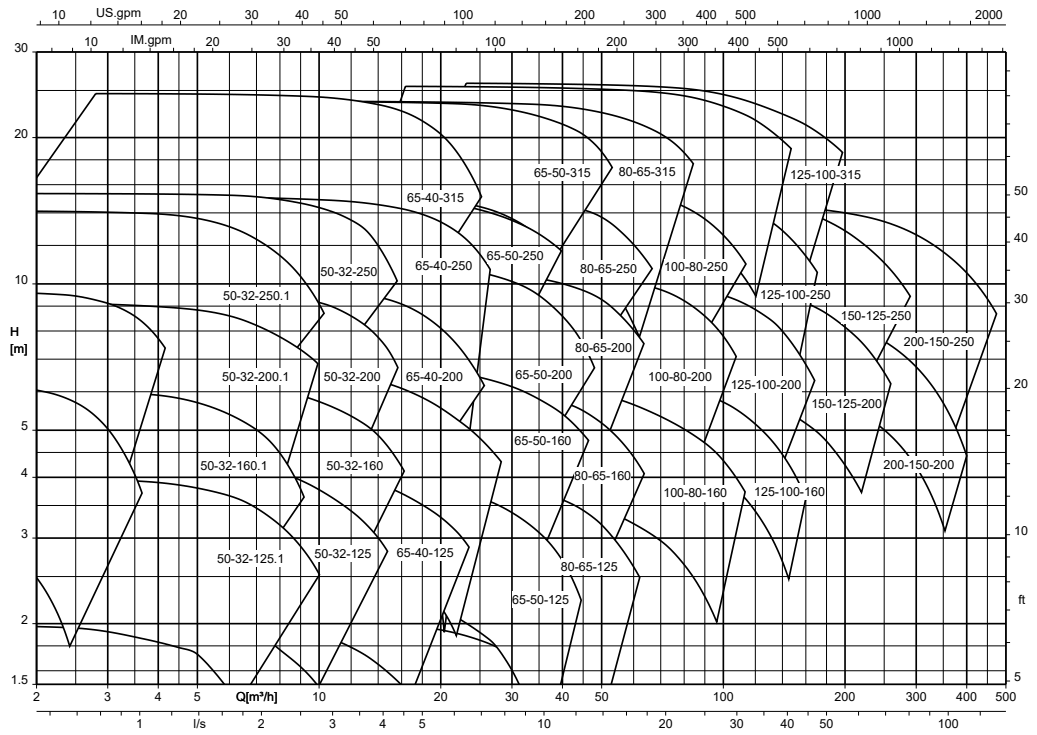

1173.5/09-EN

Connections

Single mechanical seal in A-type cover (AV), API Plan 03 (⇒ Page 6) / Single mechanical seal in A-type cover with internal circulation (IA), API Plan: 01 (⇒ Page 6)

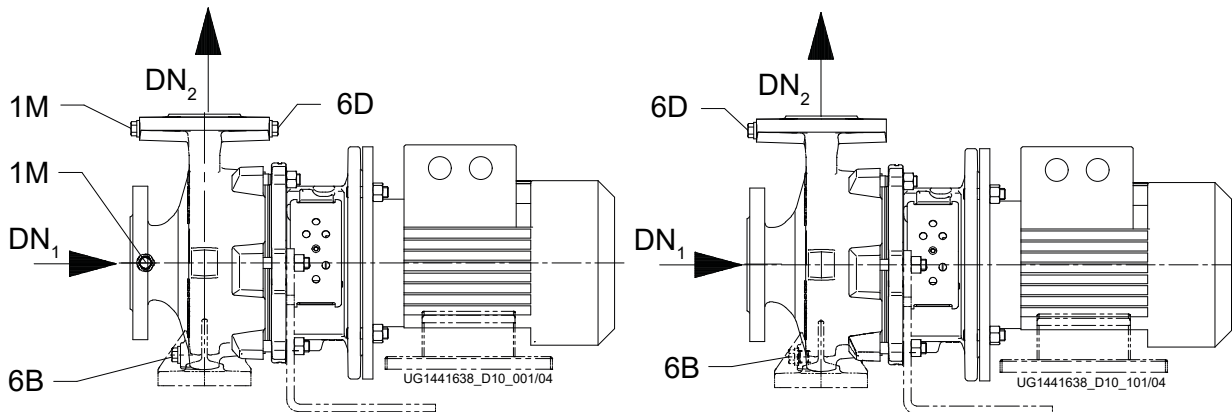

Fig. 3: Left: Version with pressure gauge connection; right: Version without pressure gauge connection

Single mechanical seal in A-type cover with external circulation (EA), API Plan: 11 (⇒ Page 6)

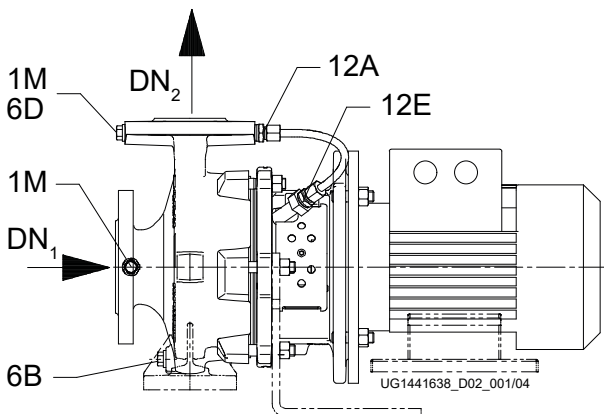

Fig. 4: Version with pressure gauge connection

Single mechanical seal in A-type cover with external flushing (FA), API Plan: 32 (⇒ Page 6)

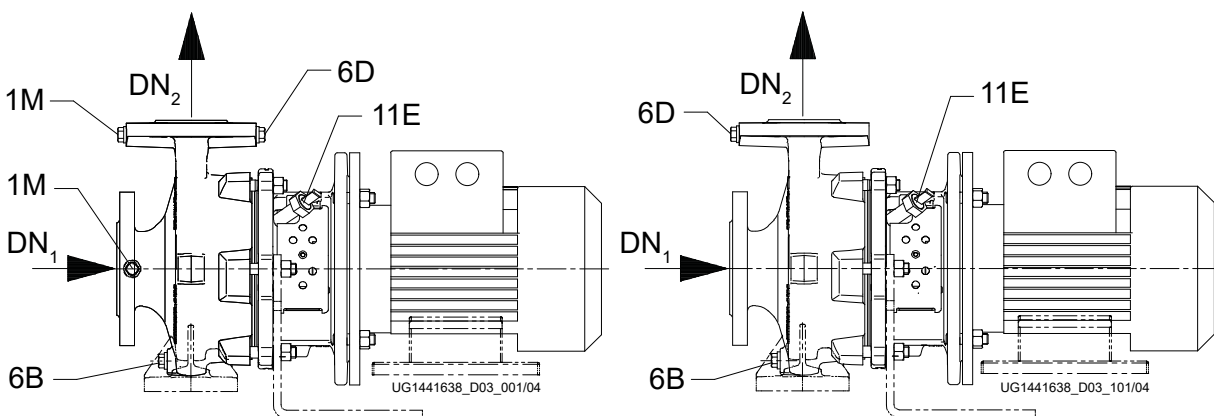

Fig. 5: Left: Version with pressure gauge connection; right: Version without pressure gauge connection

Single mechanical seal in A-type cover (AV) with discharge nozzle turned by 90°, API Plan: 03 (⇒ Page 6)

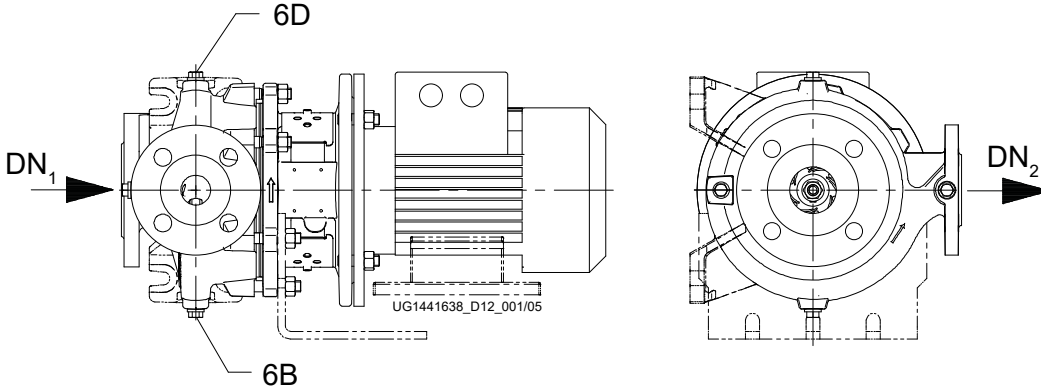

Fig. 6: Version without pressure gauge connection

Single mechanical seal in A-type cover with venting if vertically installed (AV), API Plan: 03 (⇒ Page 6)

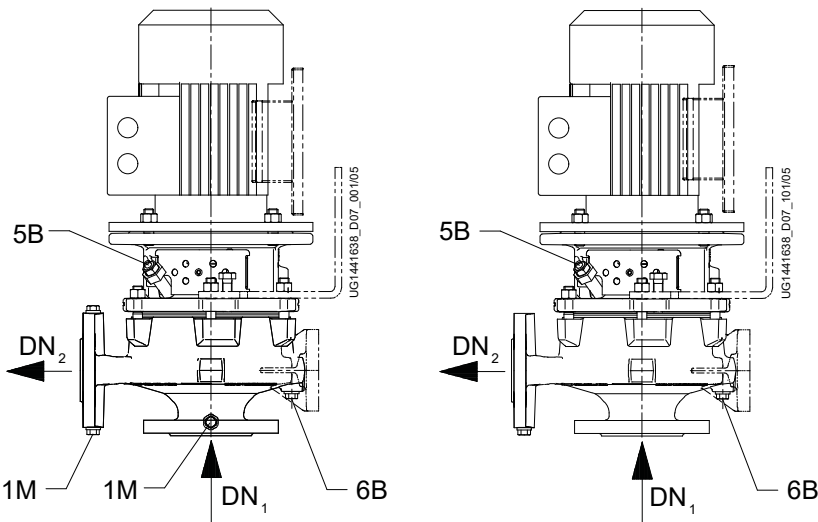

Fig. 7: Left: Version with pressure gauge connection; right: Version without pressure gauge connection

Single mechanical seal in A-type cover with external flushing (FA) and venting if vertically installed, API Plan: 32 (⇒ Page 6)

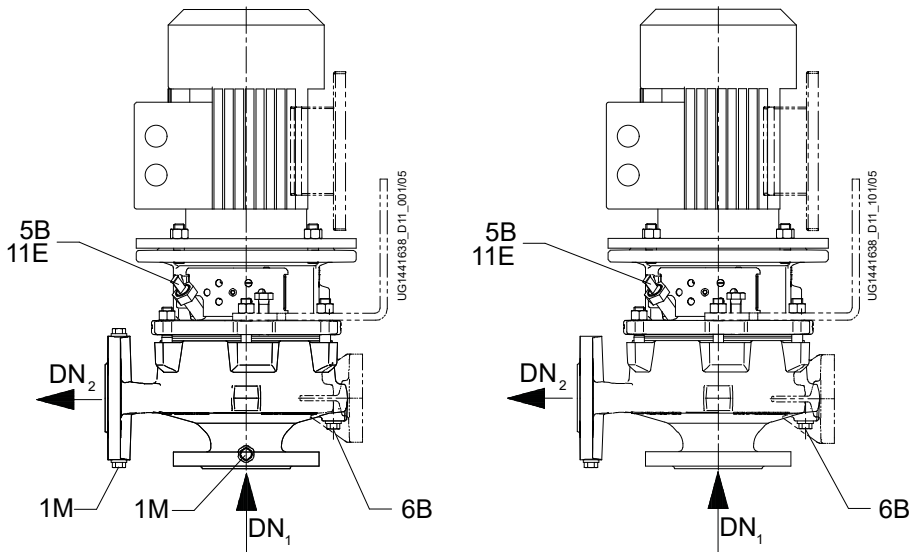

Fig. 8: Left: Version with pressure gauge connection; right: Version without pressure gauge connection

1173.5/09-EN

Double mechanical seal in back-to-back arrangement (DB), API Plan: 53A (⇒ Page 6)

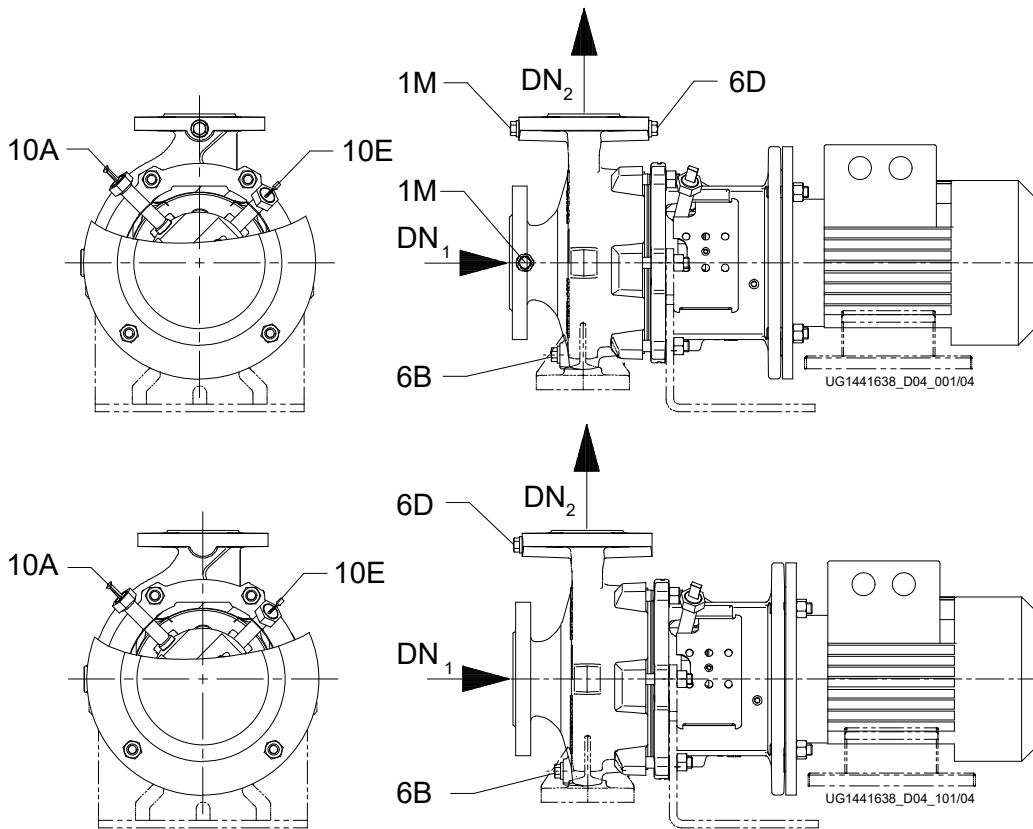

Fig. 9: Top: Version with pressure gauge connection; bottom: Version without pressure gauge connection

Double mechanical seal in tandem arrangement (TI), API Plan: 52/55 (⇒ Page 6)

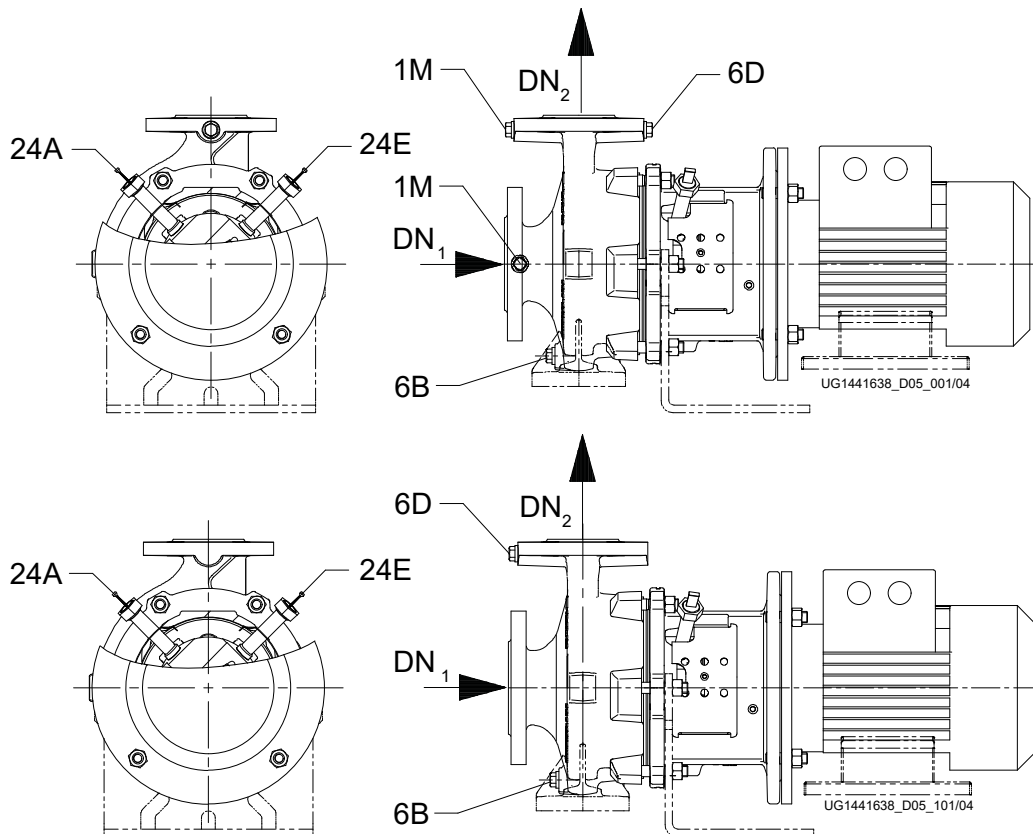

Fig. 10: Top: Version with pressure gauge connection; bottom: Version without pressure gauge connection

Table 18: Connections, * = optional

Connection	Description	Configuration	Position
1M*	Pressure gauge with connection	On pump set with pressure sensor	DN ₂
1M*	Pressure gauge with connection	Drilled and closed or with pressure sensor	DN ₁
5B	Vent	Connection G 1/4 fitting, closed	-
6B	Fluid drain	Drilled and closed	-
6D	Fluid priming and venting	Drilled and closed	DN ₂ , suction side
6D*	Fluid priming and venting	Drilled and closed	DN ₂ , drive end
10A*	External barrier water outlet	Connection G 1/4 fitting, closed	-
10E*	External barrier water inlet	Connection G 1/4 fitting, closed	-
11E*	Flushing liquid inlet	Connection G 1/4 fitting, closed	-
12A*	Circulation liquid outlet	Drilled and connected	DN ₂ , drive end
12E*	Circulation liquid inlet	Drilled and connected	-
24A*	Quench fluid outlet	Connection G 1/4 fitting, closed	-
24E*	Quench fluid inlet	Connection G 1/4 fitting, closed	-

Table 19: Connections

Size	Shaft unit	Pump casing material						
		G, B, C, S						
		Connection						
		1M / 6B / 6D	5B	10A/ 10E	11E	12A	12E	24A/ 24E
040-025-160	25	G 1/4	G 1/4	G 1/4	G 1/4	G 1/4	G 1/4	G 1/4
040-025-200	25	G 1/4	G 1/4	G 1/4	G 1/4	G 1/4	G 1/4	G 1/4
050-032-125.1	25	G 1/4	G 1/4	G 1/4	G 1/4	G 1/4	G 1/4	G 1/4
050-032-160.1	25	G 1/4	G 1/4	G 1/4	G 1/4	G 1/4	G 1/4	G 1/4
050-032-200.1	25	G 1/4	G 1/4	G 1/4	G 1/4	G 1/4	G 1/4	G 1/4
050-032-250.1	25	G 1/4	G 1/4	G 1/4	G 1/4	G 1/4	G 1/4	G 1/4
050-032-125	25	G 1/4	G 1/4	G 1/4	G 1/4	G 1/4	G 1/4	G 1/4
050-032-160	25	G 1/4	G 1/4	G 1/4	G 1/4	G 1/4	G 1/4	G 1/4
050-032-200	25	G 1/4	G 1/4	G 1/4	G 1/4	G 1/4	G 1/4	G 1/4
050-032-250	25	G 1/4	G 1/4	G 1/4	G 1/4	G 1/4	G 1/4	G 1/4
065-040-125	25	G 1/4	G 1/4	G 1/4	G 1/4	G 1/4	G 1/4	G 1/4
065-040-160	25	G 1/4	G 1/4	G 1/4	G 1/4	G 1/4	G 1/4	G 1/4
065-040-200	25	G 1/4	G 1/4	G 1/4	G 1/4	G 1/4	G 1/4	G 1/4
065-040-250	25	G 1/4	G 1/4	G 1/4	G 1/4	G 1/4	G 1/4	G 1/4
065-040-315	35	G 1/4	G 1/4	G 1/4	G 1/4	G 1/4	G 1/4	G 1/4
065-050-125	25	G 1/4	G 1/4	G 1/4	G 1/4	G 1/4	G 1/4	G 1/4
065-050-160	25	G 1/4	G 1/4	G 1/4	G 1/4	G 1/4	G 1/4	G 1/4
065-050-200	25	G 1/4	G 1/4	G 1/4	G 1/4	G 1/4	G 1/4	G 1/4
065-050-250	25	G 1/4	G 1/4	G 1/4	G 1/4	G 1/4	G 1/4	G 1/4
065-050-315	35	G 1/4	G 1/4	G 1/4	G 1/4	G 1/4	G 1/4	G 1/4
080-065-125	25	G 3/8	G 1/4	G 1/4	G 1/4	G 3/8	G 1/4	G 1/4
080-065-160	25	G 3/8	G 1/4	G 1/4	G 1/4	G 3/8	G 1/4	G 1/4
080-065-200	25	G 3/8	G 1/4	G 1/4	G 1/4	G 3/8	G 1/4	G 1/4
080-065-250	35	G 3/8	G 1/4	G 1/4	G 1/4	G 3/8	G 1/4	G 1/4
080-065-315	35	G 3/8	G 1/4	G 1/4	G 1/4	G 3/8	G 1/4	G 1/4
100-080-160	25	G 3/8	G 1/4	G 1/4	G 1/4	G 3/8	G 1/4	G 1/4
100-080-200	35	G 3/8	G 1/4	G 1/4	G 1/4	G 3/8	G 1/4	G 1/4
100-080-250	35	G 3/8	G 1/4	G 1/4	G 1/4	G 3/8	G 1/4	G 1/4
100-080-315	35	G 3/8	G 1/4	G 1/4	G 1/4	G 3/8	G 1/4	G 1/4
100-080-400	55	G 3/8	G 1/4	G 1/4	G 1/4	G 3/8	G 1/4	G 1/4
125-100-160	35	G 1/2	G 1/4	G 1/4	G 1/4	G 1/2	G 1/4	G 1/4
125-100-200	35	G 1/2	G 1/4	G 1/4	G 1/4	G 1/2	G 1/4	G 1/4
125-100-250	35	G 1/2	G 1/4	G 1/4	G 1/4	G 1/2	G 1/4	G 1/4
125-100-315	35	G 1/2	G 1/4	G 1/4	G 1/4	G 1/2	G 1/4	G 1/4
125-100-400	55	G 1/2	G 1/4	G 1/4	G 1/4	G 1/2	G 1/4	G 1/4
150-125-200	35	G 1/2	G 1/4	G 1/4	G 1/4	G 1/2	G 1/4	G 1/4
150-125-250	35	G 1/2	G 1/4	G 1/4	G 1/4	G 1/2	G 1/4	G 1/4

Size	Shaft unit	Pump casing material						
		G, B, C, S						
		Connection						
		1M / 6B / 6D	5B	10A/ 10E	11E	12A	12E	24A/ 24E
150-125-315	55	G 1/2	G 1/4	G 1/4	G 1/4	G 1/2	G 1/4	G 1/4
150-125-400	55	G 1/2	G 1/4	G 1/4	G 1/4	G 1/2	G 1/4	G 1/4
200-150-200	35	G 1/2	G 1/4	G 1/4	G 1/4	G 1/2	G 1/4	G 1/4
200-150-250	35	G 1/2	G 1/4	G 1/4	G 1/4	G 1/2	G 1/4	G 1/4
200-150-315	55	G 1/2	G 1/4	G 1/4	G 1/4	G 1/2	G 1/4	G 1/4
200-150-400	55	G 1/2	G 1/4	G 1/4	G 1/4	G 1/2	G 1/4	G 1/4

Discharge nozzle positions

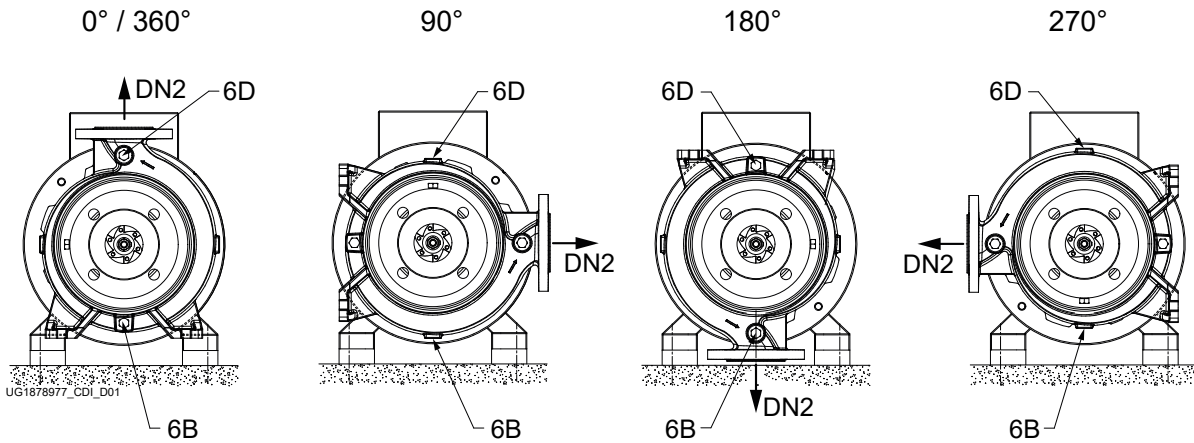

Fig. 11: Nozzle positions

Table 20: Overview

Nozzle position Discharge nozzle	Material variant				Installation		Possible options	
	GG, GB, GC	BB	CC	SG, SB, SC	Horizontal	Vertical	PumpDrive	PumpMeter
0°	X	X	X	X	X	X	X	X
90°	X	-	X	-	X	X	X	-
180°	X	X	X	X	X	X	X	X
270°	X	-	X	-	X	X	X	-

Flange design

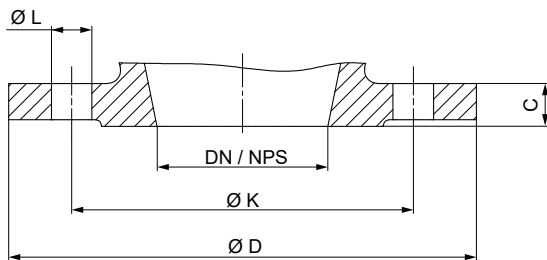

Fig. 12: Flange dimensions

Flange dimensions to EN 1092-1, EN 1092-3
Table 21: Flange dimensions [mm]

Nominal size	Standard								
	EN 1092-3			EN 1092-1					
	Material variant of volute casing								
	B			C					
	PN 10			PN 10			PN 16		
Ø D	Ø K	Number x Ø L	Ø D	Ø K	Number x Ø L	Ø D	Ø K	Number x Ø L	
25	115	85	4 x Ø 14	-	-	-	115	85	4 x Ø 14
32	140	100	4 x Ø 18	-	-	-	140	100	4 x Ø 18
40	150	110	4 x Ø 18	-	-	-	150	110	4 x Ø 18
50	165	125	4 x Ø 18	-	-	-	165	125	4 x Ø 18
65	185	145	4 x Ø 18	-	-	-	185	145	4 x Ø 18
80 (DN ₁) ²²⁾	229	160	8 x Ø 18	-	-	-	230	160	8 x Ø 18
80 (DN ₂) ²³⁾	200	160	8 x Ø 18	-	-	-	200	160	8 x Ø 18
100	229	180	8 x Ø 18	-	-	-	230	180	8 x Ø 18
125	254	210	8 x Ø 18	-	-	-	255	210	8 x Ø 18
150	285	240	8 x Ø 22	-	-	-	285	240	8 x Ø 22
200	343	295	8 x Ø 22	345	295	8 x Ø 22	-	-	-

Flange dimensions to EN 1092-2
Table 22: Flange dimensions [mm]

Nominal size	Standard								
	EN 1092-2								
	Material variant of volute casing								
	G						S		
	PN 10			PN 16			PN 16		
Ø D	Ø K	Number x Ø L	Ø D	Ø K	Number x Ø L	Ø D	Ø K	Number x Ø L	
25	-	-	-	115	85	4 x Ø 14	115	85	4 x Ø 14
32	-	-	-	140	100	4 x Ø 19	140	100	4 x Ø 19
40	-	-	-	150	110	4 x Ø 19	150	110	4 x Ø 19
50	-	-	-	165	125	4 x Ø 19	165	125	4 x Ø 19
65	-	-	-	185	145	4 x Ø 19	185	145	4 x Ø 19
80 (DN ₁) ²²⁾	-	-	-	229	160	8 x Ø 19	229	160	8 x Ø 19
80 (DN ₂) ²³⁾	-	-	-	200	160	8 x Ø 19	200	160	8 x Ø 19
100	-	-	-	229	180	8 x Ø 19	229	180	8 x Ø 19
125	-	-	-	254	210	8 x Ø 19	254	210	8 x Ø 19
150	-	-	-	285	240	8 x Ø 23	285	240	8 x Ø 23
200	343	295	8 x Ø 23	-	-	-	343	295	12 x Ø 23

Flange drilled to: ASME B 16.1, Class 125, ASME B 16.5, Class 150
Table 23: Flange dimensions [mm]

Nominal size	Standard						
	ASME B 16.1, Class 125, ASME B 16.5, Class 150						
	Material variant of volute casing						
	B, G, S			C			
	Ø D	Ø K	Number x Ø L	Ø D	Ø K	Number x Ø L	
25/ NPS 1	115	79	4 x Ø 15,7	115	79,2	4 x Ø 15,9	
32/ NPS 1 1/4	140	89	4 x Ø 15,7	140	88,9	4 x Ø 15,9	
40/ NPS 1 1/2	150	98	4 x Ø 15,7	150	98,6	4 x Ø 15,9	
50/ NPS 2	165	121	4 x Ø 19,1	165	120,7	4 x Ø 19,1	
65/ NPS 2 1/2	185	140	4 x Ø 19,1	185	139,7	4 x Ø 19,1	

²² Suction flange; suction line NPS 4 must be used.

²³ Discharge flange

Nominal size	Standard					
	ASME B 16.1, Class 125, ASME B 16.5, Class 150					
	Material variant of volute casing					
	B, G, S			C		
	Ø D	Ø K	Number x Ø L	Ø D	Ø K	Number x Ø L
80/ NPS 3 (DN ₁) ²²⁾	229	191	8 x Ø 19,1	230	190,5	8 x Ø 19,1
80/ NPS 3 (DN ₂) ²³⁾	200	152	4 x Ø 19,1	200	152,4	4 x Ø 19,1
100/ NPS 4	229	191	8 x Ø 19,1	230	190,5	8 x Ø 19,1
125/ NPS 5	254	216	8 x Ø 22,4	255	215,9	8 x Ø 22,2
150/ NPS 6	285	241	8 x Ø 22,4	285	241,3	8 x Ø 22,2
200/ NPS 8	345	299	8 x Ø 22,4	345	298,5	8 x Ø 22,2

Table 24: Flange design by materials

Material variant	Standard	Nominal size	Pressure class
GG, GB, GC	EN 1092-2	DN 25 - DN 150	PN 16
		DN 200	PN 10
	Drilled to ASME B16.1 ²⁴⁾	DN 25 - DN 200	Class 125 ²⁵⁾
SG, SB, SC	EN 1092-2	DN 25 - DN 200	PN 16
	Drilled to ASME B16.1 ²⁴⁾	DN 25 - DN 200	Class 125 ²⁵⁾
BB	EN 1092-3	DN 25 - DN 200	PN 10
	Drilled to ASME B16.1 ²⁴⁾	DN 25 - DN 200	Class 125 ²⁶⁾
CC	EN 1092-1	DN 25 - DN 150	PN 16
		DN 200	PN 10
	Drilled to ASME B16.5 ²⁴⁾	DN 25 - DN 200	Class 150

²⁴⁾ Suction-side DN 80 machined like DN 100

²⁵⁾ Nozzle drilled to Class 125 with pressure class PN 16

²⁶⁾ Nozzle drilled to Class 125 with pressure class PN 10

Installation types

Table 25: Symbols key

Symbol	Description
*	Symbolises areas in which the pump set is connected to the foundation.
A	PumpDrive, motor-mounted
B	PumpDrive, wall-mounted
C	PumpDrive, cabinet-mounted
O	Without PumpDrive

Table 26: Overview of installation types

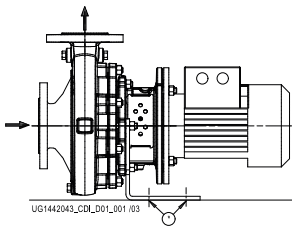
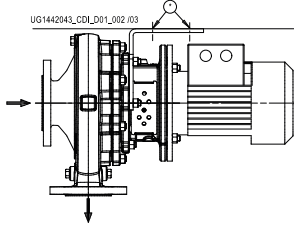
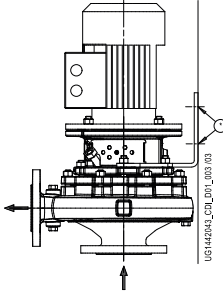
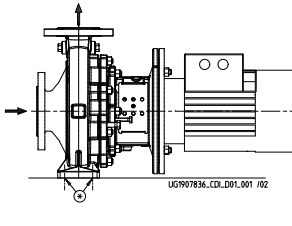
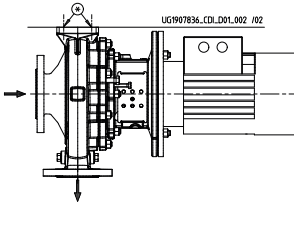
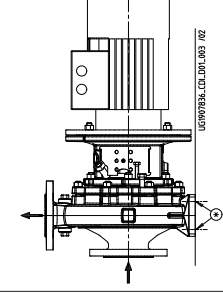
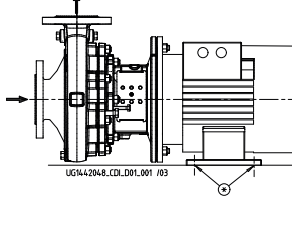
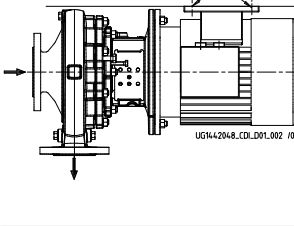
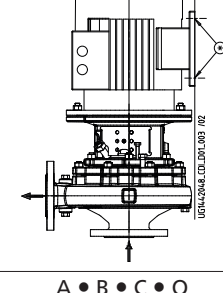
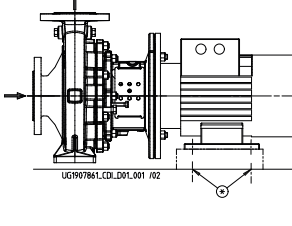
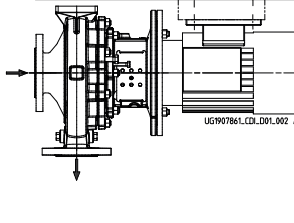
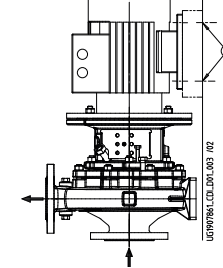
IEC motor	Pump foot provided	Fastening	Installation types incl. PumpDrive variants		
			Horizontal installation, floor-mounted	Horizontal installation, ceiling-mounted	Vertical installation
71 to 112	No	Support foot ²⁷⁾ or suspended in the piping	 <p>UG1442043_CCI_D01_001 #03</p> <p>A • B • C • O</p>	 <p>UG1442043_CCI_D01_002 #03</p> <p>B • C • O</p>	 <p>UG1442043_CCI_D01_003 #03</p> <p>A • B • C • O</p>
	Yes	Volute casing foot ²⁷⁾ or suspended in the piping	 <p>UG1907836_CCI_D01_001 #02</p> <p>A • B • C • O</p>	 <p>UG1907836_CCI_D01_002 #02</p> <p>B • C • O</p>	 <p>UG1907836_CCI_D01_003 #02</p> <p>A • B • C • O</p>
132 to 180	No	Motor foot ²⁷⁾	 <p>UG1442048_CCI_D01_001 #03</p> <p>A • B • C • O</p>	 <p>UG1442048_CCI_D01_002 #03</p> <p>B • C • O</p>	 <p>UG1442048_CCI_D01_003 #03</p> <p>A • B • C • O</p>
	Yes	Motor foot ²⁷⁾	 <p>UG1907861_CCI_D01_001 #02</p> <p>A • B • C • O</p>	 <p>UG1907861_CCI_D01_002 #02</p> <p>B • C • O</p>	 <p>UG1907861_CCI_D01_003 #02</p> <p>A • B • C • O</p>

1173.5/09-EN

²⁷⁾ Shims may be required. The required shims are **not** included in KSB's scope of supply.

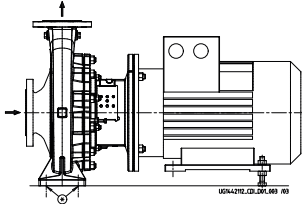
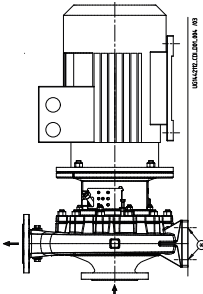
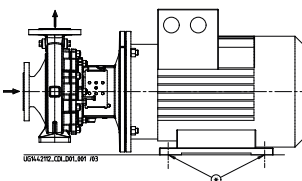
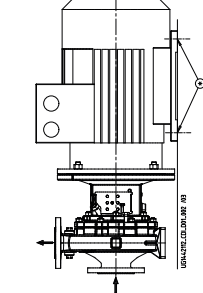
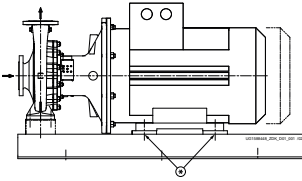
IEC motor	Pump foot provided	Fastening	Installation types incl. PumpDrive variants		
			Horizontal installation, floor-mounted	Horizontal installation, ceiling-mounted	Vertical installation
132 to 180	Yes	Motor foot ²⁷⁾	A • B • C • O	B • C • O	A • B • C • O
200 to 315	Yes	Pump foot ²⁷⁾ ; motor foot supported but not fastened		Not available	
			200 to 225: A • B • C • O 250 to 315: O	-	200 to 225: A • B • C • O 250 to 315: O
	Motor foot ²⁷⁾ ; pump foot supported ²⁷⁾ but not fastened		Not available		
		200 to 225: A • B • C • O 250 to 315: O	-	200 to 225: A • B • C • O 250 to 315: O	
250 to 315	Yes	Pump set on base-plate; motor fastened, shims under pump		Not available	Not available
			O	-	-

Scope of supply

Depending on the model, the following items are included in the scope of supply:

- Pump
- Drive
- PumpDrive
- PumpMeter

Recommended spare parts stock
Table 27: Quantity of spare parts for recommended spare parts stock for commissioning

Part No.	Description	Number of pumps									
		1	2	3	4	5	6	7	8	9	10 and more
433	Mechanical seal	1	1	1	2	2	2	2	3	3	25 %
433.01/.02	Mechanical seal ²⁸⁾	1	1	1	2	2	2	2	3	3	25 %
400.10	Gasket	2	4	6	8	8	9	9	12	12	150 %
400.75	Gasket	2	4	6	8	8	9	9	12	12	150 %
400.15	Gasket ²⁸⁾	2	4	6	8	8	9	9	12	12	150 %
411.15	Joint ring ²⁸⁾	2	4	6	8	8	9	9	12	12	150 %
412.15	O-ring ²⁸⁾	2	4	6	8	8	9	9	12	12	150 %

Table 28: Quantity of spare parts for recommended spare parts stock for 2 years' operation to DIN 24296

Part No.	Description	Number of pumps									
		1	2	3	4	5	6	7	8	9	10 and more
210	Shaft	1	1	1	1	2	2	2	2	2	20 %
230	Impeller	1	1	1	1	2	2	2	2	2	20 %
433	Mechanical seal	1	1	1	2	2	2	2	3	3	25 %
433.01/.02	Mechanical seal ²⁸⁾	1	1	1	2	2	2	2	3	3	25 %
502.01/.02	Casing wear ring ²⁹⁾ (set)	1	2	2	2	3	3	3	4	4	50 %
523	Shaft sleeve	1	2	2	2	3	3	3	4	4	50 %
400.10	Gasket	2	4	6	8	8	9	9	12	12	150 %
400.75	Gasket	2	4	6	8	8	9	9	12	12	150 %
400.15	Gasket ²⁸⁾	2	4	6	8	8	9	9	12	12	150 %
411.15	Joint ring ²⁸⁾	2	4	6	8	8	9	9	12	12	150 %
412.15	O-ring ²⁸⁾	2	4	6	8	8	9	9	12	12	150 %

²⁸⁾ For double mechanical seal

²⁹⁾ If any

General assembly drawings

Version with single mechanical seal and bolted casing cover

Table 29: This illustration applies to the following pump sizes:

040-025-200	050-032-200.1	050-032-200	065-040-200	065-050-200	080-065-200	100-80-250	125-100-250	150-125-250	200-150-250
	050-032-250.1	050-032-250	065-040-250	065-050-250	080-065-250	100-80-315	125-100-315	150-125-315	200-150-315
			065-040-315	065-050-315	080-065-315	100-80-400	125-100-400	150-125-400	200-150-400

Supplied in packaging units only

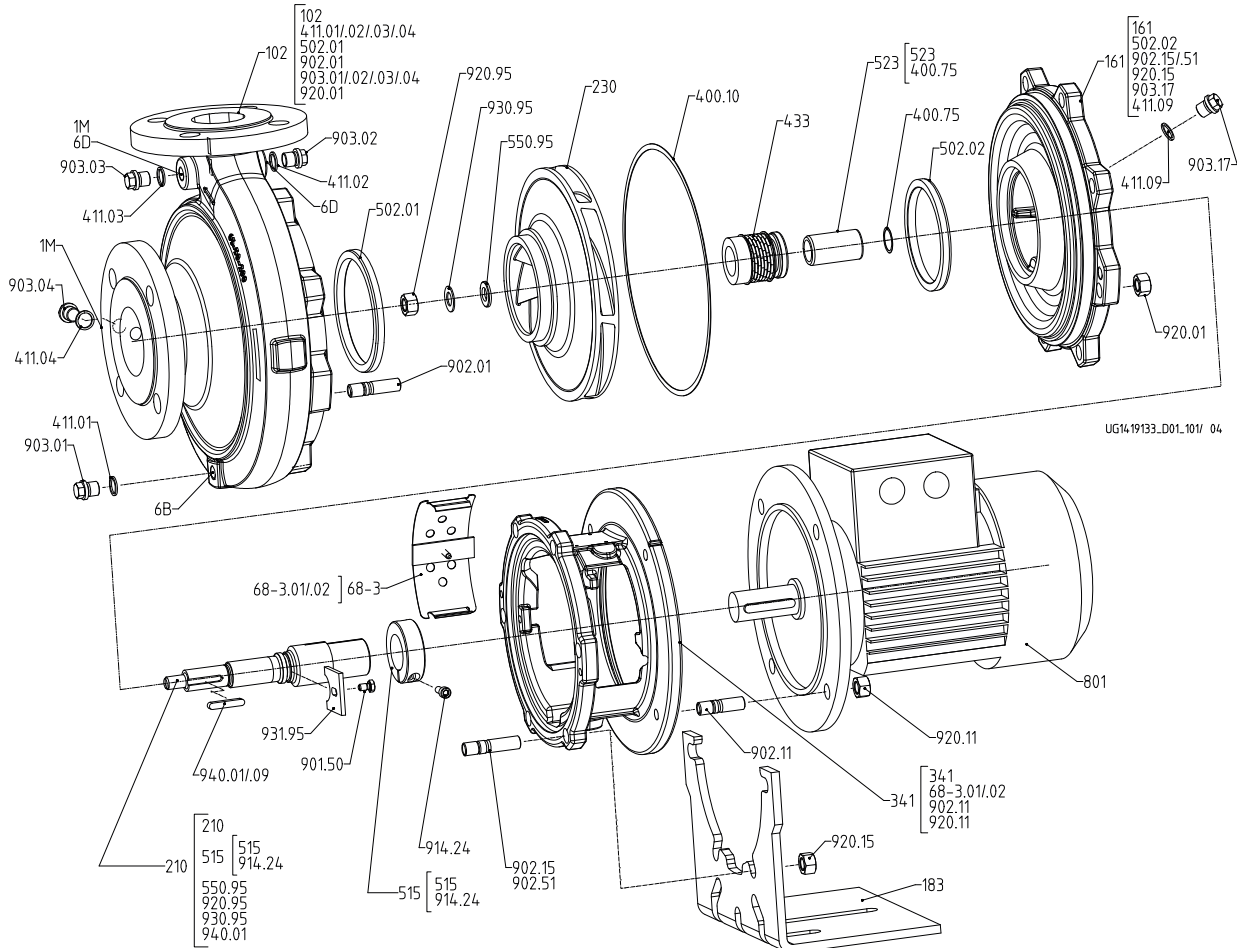

Fig. 13: Version with single mechanical seal and bolted casing cover, without pump foot

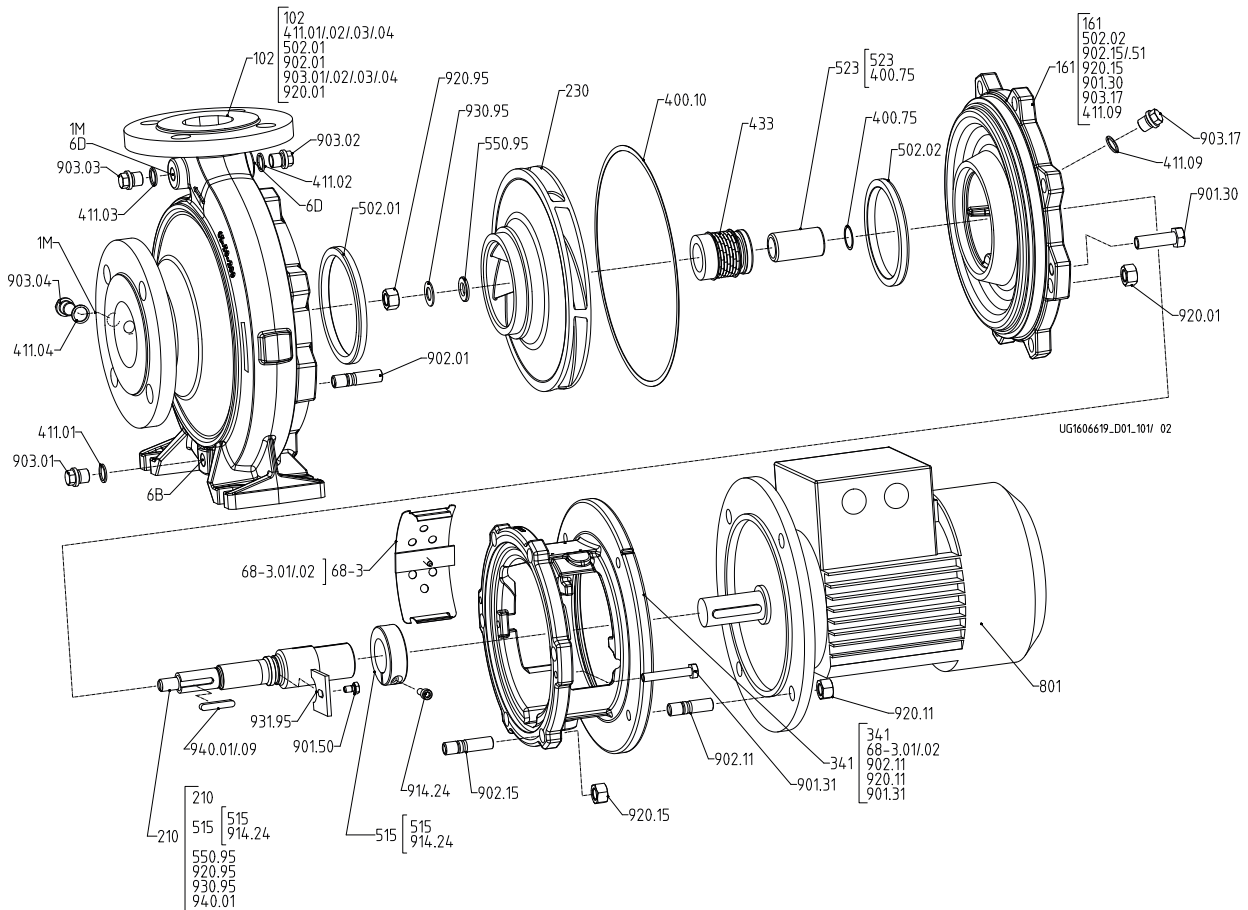

Fig. 14: Version with single mechanical seal and bolted casing cover, with pump foot

Table 30: List of components³⁰⁾

Part No.	Description	Part No.	Description
102	Volute casing	523	Shaft sleeve
146	Intermediate lantern	550.95	Disc
161	Casing cover	68-3.01/.02	Cover plate
183	Support foot	801	Flanged motor
210	Shaft	901.30 ³¹⁾ /31 ³¹⁾ /50	Hexagon head bolt
230	Impeller	902.01/.06/.11/.15/.50/.51	Stud
341	Drive lantern	903.01/.02/.03/.04/.08 ³²⁾ /.17	Screw plug
400.10/.75	Gasket	914.24	Hexagon socket head cap screw
411.01/.02/.03/.04/.08/.09	Joint ring	920.01/.06/.11/.15/.95	Nut
433	Mechanical seal	930.95	Spring washer
502.01/.02	Casing wear ring	931.95	Lock washer
515	Locking ring	940.01/09 ³³⁾	Key

Table 31: Connections

Part No.	Description	Part No.	Description
1M	Pressure gauge with connection	6D	Fluid priming and venting
6B	Fluid drain		

1173.5/09-EN

³⁰⁾ Some individual components might not be applicable, depending on the pump size and material.

³¹⁾ Not available for version without pump foot

³²⁾ Not shown in the drawing

³³⁾ For shaft unit 55 only

Version with single mechanical seal and clamped casing cover

Table 32: This illustration applies to the following pump sizes:

040-025-160	050-032-125.1	050-032-125	065-040-125	065-050-125	080-065-125	100-80-160	125-100-160	150-125-200	200-150-200
	050-032-160.1	050-032-160	065-040-160	065-050-160	080-065-160	100-80-200	125-100-200		

Supplied in packaging units only

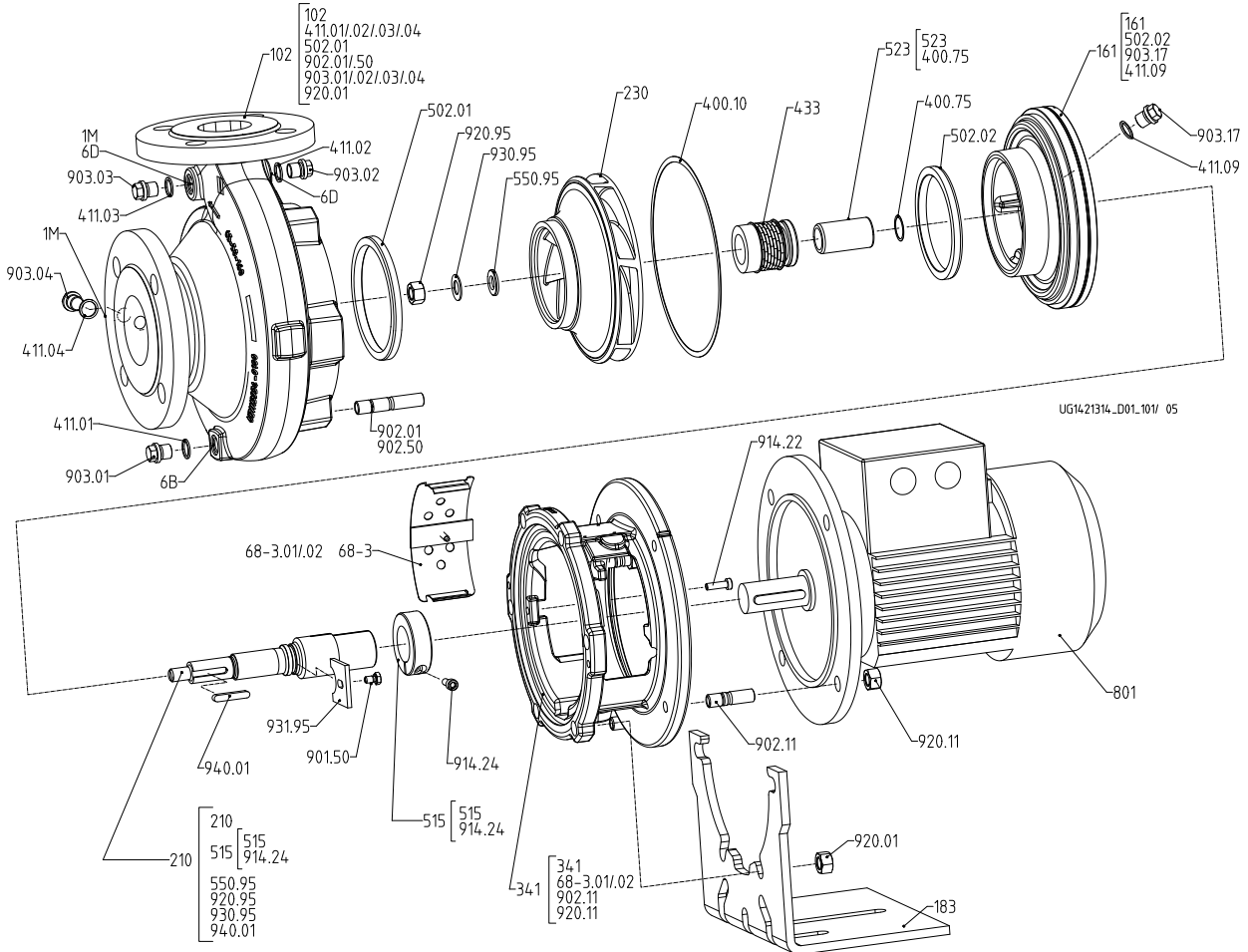

Fig. 15: Version with single mechanical seal and clamped casing cover, without pump foot

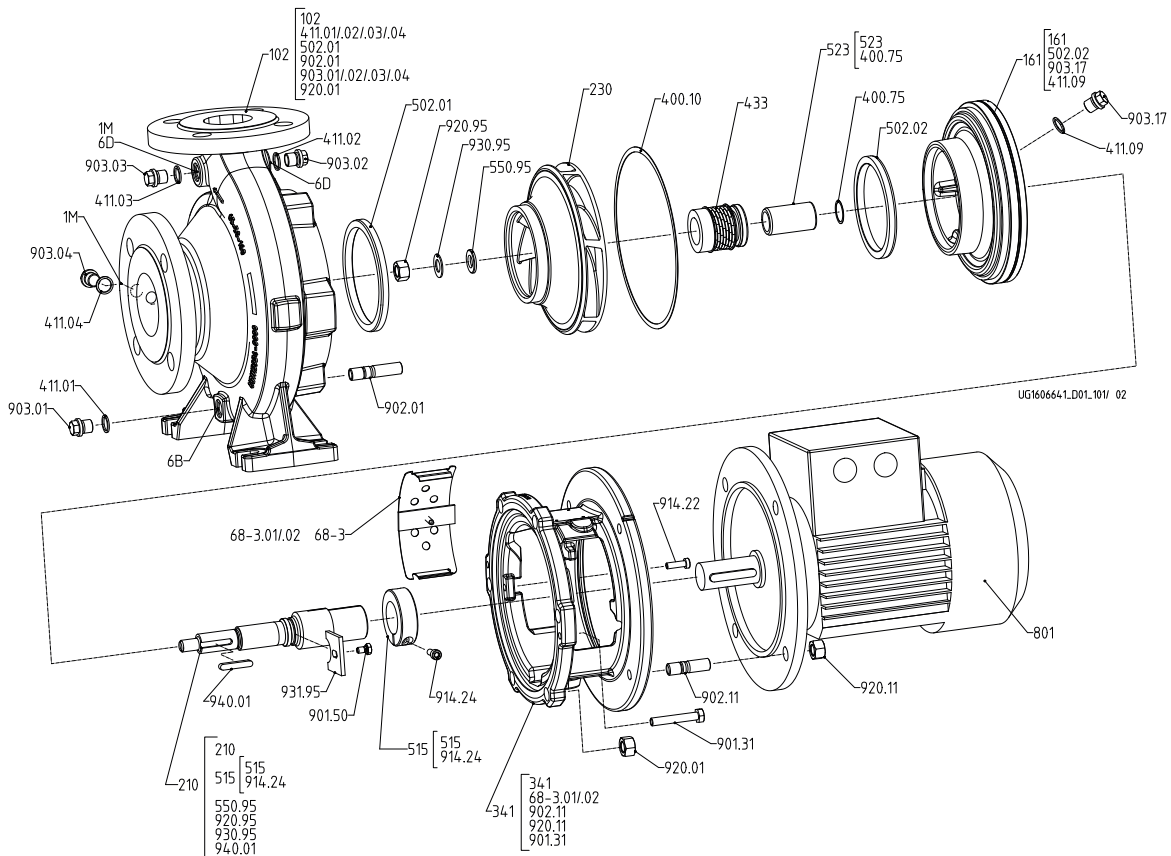

Fig. 16: Version with single mechanical seal and clamped casing cover, with pump foot

Table 33: List of components³⁴⁾

Part No.	Description	Part No.	Description
102	Volute casing	523	Shaft sleeve
146	Intermediate lantern	550.95	Disc
161	Casing cover	68-3.01/02	Cover plate
183	Support foot	801	Flanged motor
210	Shaft	901.31 ³⁵⁾ /1.50	Hexagon head bolt
230	Shaft	902.01/06/11/15/50/51	Stud
341	Drive lantern	903.01/02/03/04/08/17	Screw plug
400.10/75	Gasket	914.22/24	Hexagon socket head cap screw
411.01/02/03/04/08/09	Joint ring	920.01/06/11/15/95	Hexagon nut
433	Mechanical seal	930.95	Spring washer
502.01/02 ³⁶⁾	Casing wear ring	931.95	Lock washer
515	Locking ring	940.01	Key

Table 34: Connections

Part No.	Description	Part No.	Description
1M	Pressure gauge with connection	6D	Fluid priming and venting
6B	Fluid drain		

³⁴ Some individual components might not be applicable, depending on the pump size and material.

³⁵ Not available for version without pump foot

³⁶ Not with sizes 40-25-160, 50-32-125, 50-32-125.1, 50-32-160.1 and 65-40-125

Version with double mechanical seal in back-to-back arrangement

Supplied in packaging units only

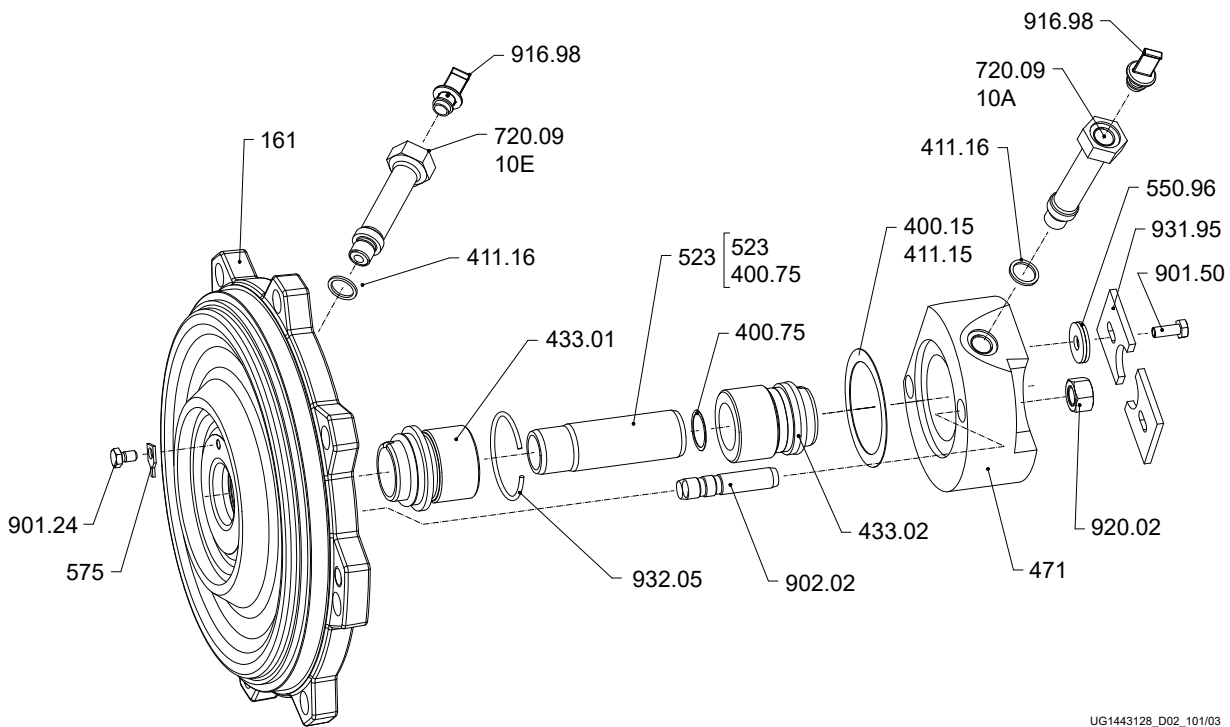

UG1443128_D02_101/03

Fig. 17: Version with double mechanical seal in back-to-back arrangement

Table 35: List of components³⁷⁾

Part No.	Description	Part No.	Description
161	Casing cover	575	Strip
400.15/.75	Gasket	720.09	Fitting
411.15/.16	Joint ring	901.24/.50	Hexagon head bolt
433.01/.02	Mechanical seal	902.02	Stud
471	Seal cover	916.98	Plug
523	Shaft sleeve	920.02	Hexagon nut
550.96	Disc	931.95	Lock washer
562.02	Parallel pin	932.05	Circlip

Table 36: Auxiliary connections

Part No.	Description	Part No.	Description
10A	External barrier water outlet	10E	External barrier water inlet

³⁷⁾ Some individual components might not be applicable, depending on the pump size and material.

Version with double mechanical seal in tandem arrangement

Supplied in packaging units only

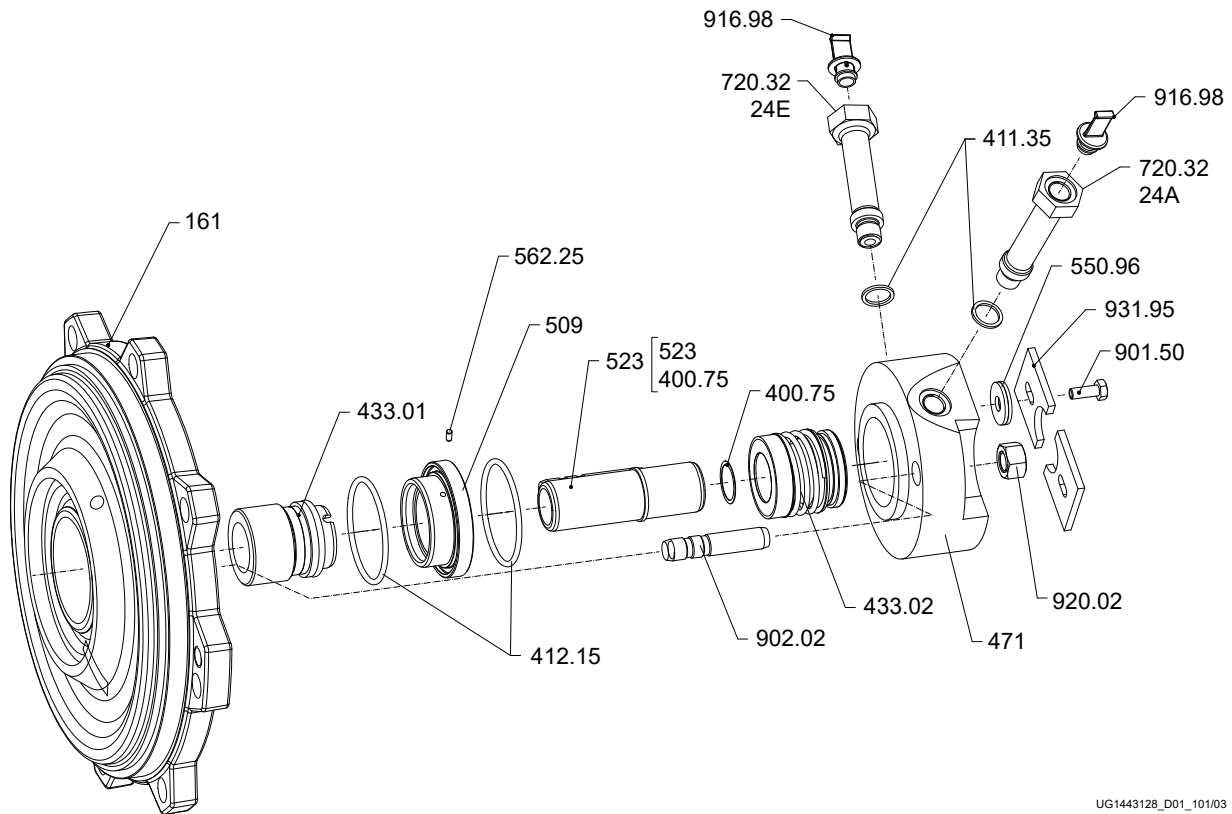

UG1443128_D01_101/03

Fig. 18: Version with double mechanical seal in tandem arrangement

Table 37: List of components³⁸⁾

Part No.	Description	Part No.	Description
161	Casing cover	550.96	Disc
400.75	Gasket	562.25	Parallel pin
411.35	Joint ring	720.32	Fitting
412.15	O-ring	901.50	Hexagon head bolt
433.01/02	Mechanical seal	902.02	Stud
471	Seal cover	916.98	Plug
509	Intermediate ring	920.02	Hexagon nut
523	Shaft sleeve	931.95	Lock washer

Table 38: Auxiliary connections

Part No.	Description	Part No.	Description
24A	Quench liquid outlet	24E	Quench liquid inlet

³⁸⁾ Some individual components might not be applicable, depending on the pump size and material.

Glossary

ACS

French drinking water regulations (ACS = Attestation de Conformité Sanitaire)

IE2

Efficiency class to IEC 60034-30: 2 = High Efficiency (IE = International Efficiency)

IE3

Efficiency class to IEC 60034-30: 3 = Premium Efficiency (IE = International Efficiency)

IE4

Efficiency class to IEC TS 60034-30-2:2016 = Super Premium Efficiency (IE = International Efficiency)

IE5

Efficiency class for rotating electrical machinery to IEC TS 60034-30-2:2016 = Ultra Premium Efficiency (IE = International Efficiency)

Mech. seal

Mechanical seal

SU

Shaft unit

UBA

German drinking water regulations to German Environment Agency

WRAS

Approved by all water suppliers in the UK (WRAS = Water Regulations Advisory Scheme)



KSB SE & Co. KGaA
Johann-Klein-Straße 9 • 67227 Frankenthal (Germany)
Tel. +49 6233 86-0
www.ksb.com