

Customer

Technical data

Glanded standard twin-head pump DPL 50/155-7,5/2 PN 10

Project ID Untitled project 2025-03-04 09:37:01.987

Project name
Installation location
Customer pos. No.

Date 2025-03-04

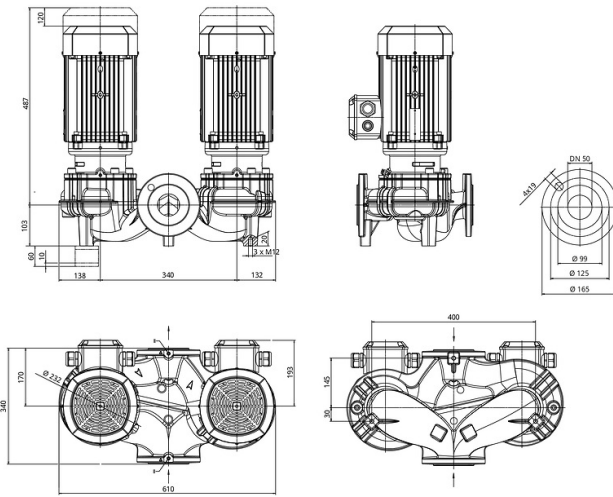
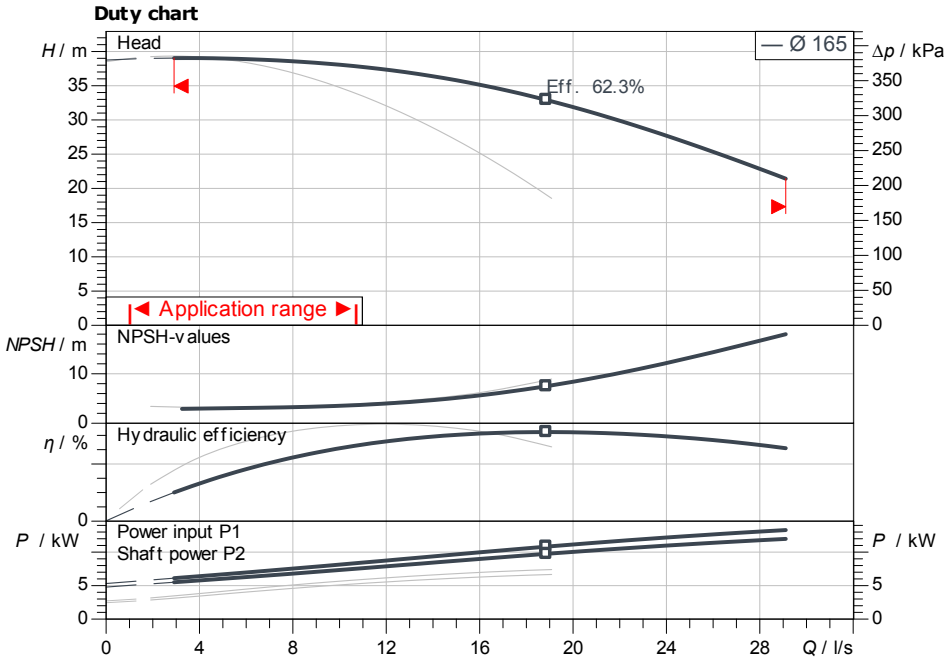

I: Druckmessanschluss R 1/8
II: Entlüftung R 1/8

Requested data

Flow	
Head	
Media	Water 100 %
Fluid temperature	20.00 °C
Density	998.30 kg/m ³
Kin. viscosity	1.00 mm ² /s

Hydraulic data (Duty point)

Flow	
Head	
Shaft power P2	
Hydraulic efficiency	
NPSH	

Product data

Glanded standard twin-head pump	
DPL 50/155-7,5/2 PN 10	
Max. operating pressure	1,000 kPa
Fluid temperature	-20 °C ... +120 °C
Max. ambient temperature	40 °C
Minimum efficiency index (MEI)	≥ 0.4

Motordata per Motor/Pump

Motor efficiency level	
Mains connection	3~ 400 V / 50 Hz
Permitted voltage tolerance	+/- 10 %
Rated speed	2,921 1/min
Rated power P2	7.50 kW
Rated current	14.70 A
Power factor	0.83
Efficiency	
50% / 75% / 100%	88.1/ 90/90.1%
Degree of protection	IP55
Insulation class	F
Motor protection	No

Fitting dimensions

Pipe connection on the suction side	DN 50, PN 16
Pipe connection (pressure side)	DN 50, PN 16
Port to Port	340 mm

Materials

Pump housing	5.1301, EN-GJL-250 cast
Impeller	EN-GJL-200
Lantern	5.1301/EN-GJL-250
Shaft	1.4122
Shaft seal	AQ1EGG

Information for order placements

Weight approx.	145 kg
Item number	2231856