

**Customer**

## Technical data

### Non self-priming multistage centrifugal pump MHI 405-1/E/3-400-50-2/I E3

Project ID: Untitled project 2025-03-03 06:59:09.769

Project name  
Installation location  
Customer pos. No.

Date: 2025-03-03

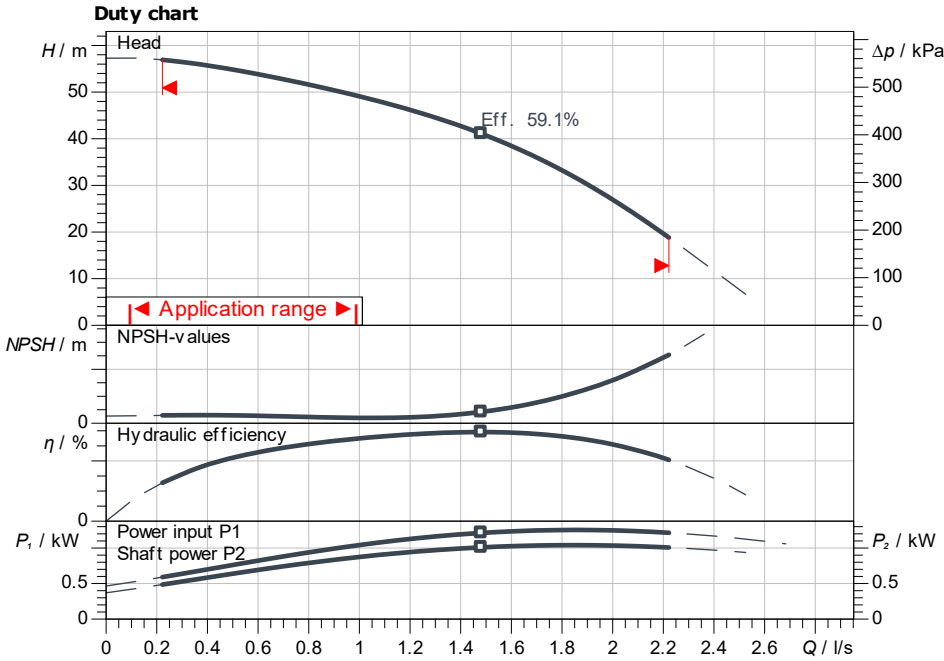

ISO 9906: 2012 3B

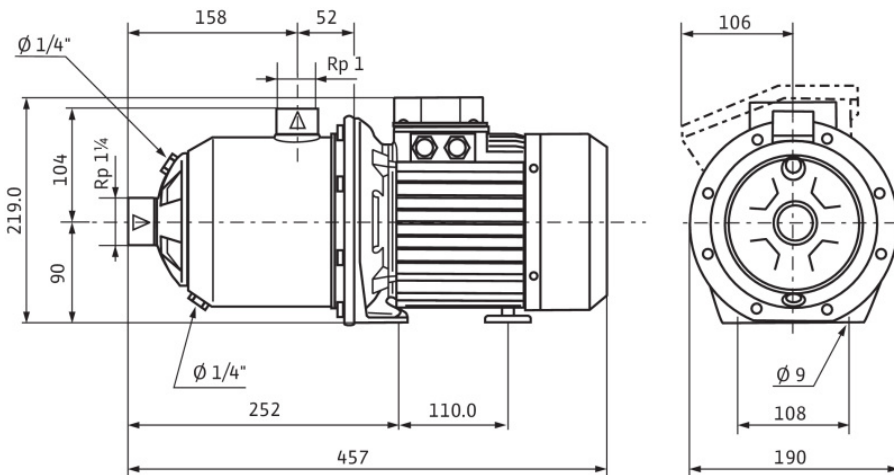

#### Requested data

Flow	
Head	
Media	Water 100 %
Fluid temperature	20.00 °C
Density	998.30 kg/m <sup>3</sup>
Kin. viscosity	1.00 mm <sup>2</sup> /s

#### Hydraulic data (Duty point)

Flow	
Head	
Shaft power P2	
Hydraulic efficiency	
NPSH	

#### Product data

Non self-priming multistage centrifugal pump MHI 405-1/E/3-400-50-2/I E3	
Max. operating pressure	1,000 kPa
Inlet pressure max.	6 bar
Fluid temperature	-15 °C ... +110 °C
Max. ambient temperature	40 °C

#### Motordata per Motor/Pump

Motor efficiency level	IE3
Mains connection	3~ 400 V / 50 Hz
Permitted voltage tolerance	+10 %
Max. speed	2,900 1/min
Rated power P2	1.10 kW
Rated current	2.80 A
Power factor	0.83
Efficiency	50% / 75% / 100%
Degree of protection	IP54
Insulation class	F
Motor protection	

#### Fitting dimensions

Pipe connection on the suction side	Rp 1 1/4, PN 10
Pipe connection (pressure side)	Rp 1, PN 10

#### Materials

Pump housing	1.4301
Impeller	1.4404
Shaft	1.4301
Shaft seal	BQ7EGG
Gasket material	EPDM

#### Information for order placements

Weight approx.	15.1 kg
Item number	4210732

**Dimensions** mm