

Customer

Technical data

Multi-pump system

Isar MODH1-2CH1-L-1005/SCe

Project ID: Untitled project 2025-03-03 22:14:23.954

Project name
Installation location
Customer pos. No.

Date: 2025-03-03

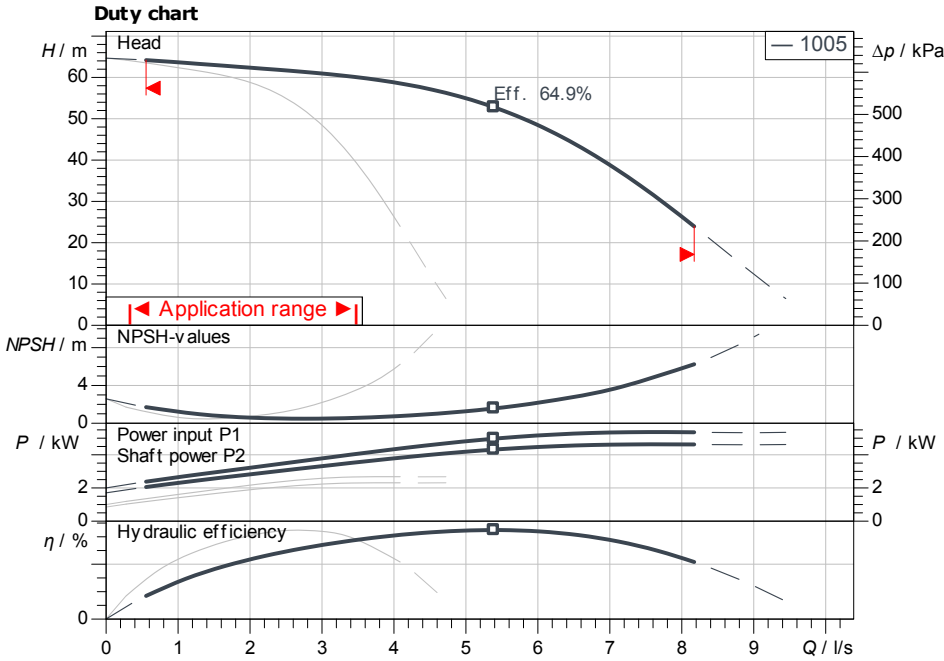

Requested data

Flow
Head
Media: Water 100 %
Fluid temperature: 20.00 °C
Density: 998.30 kg/m³
Kin. viscosity: 1.00 mm²/s

Hydraulic data (Duty point)

Flow
Head
Shaft power P2

Product data

Multi-pump system
Isar MODH1-2CH1-L-1005/SCe
Control: With frequency converter
No. of pumps: 2
Max. operating pressure: 1,000 kPa
Inlet pressure max.: 6 bar
Fluid temperature: 3 °C ... +60 °C
Max. ambient temperature: 40 °C
Diaphragm pressure vessel: Yes
Low-water cut-out switchgear: Yes

Control

Mains connection: 1~220-230 V
50 Hz
Protection class of switchgear: IP54

Motordata per Motor/Pump

Motor efficiency level: IE3
Rated power P2: 2.50 kW
Rated current: 5.20 A
Efficiency: 50% / 75% / 100% → 87.4/87.4/86.4%
Protection class motor: IP55
Insulation class: F
Motor protection

Fitting dimensions

Pipe connection on the suction side: R 2, PN 10
Pipe connection (pressure side): R 2, PN 10

Materials

Pump housing: 1.4301
Impeller: 1.4301
Shaft: 1.4301
Shaft seal: BQ1E3GG
Gasket material: EPDM
Pipework material: 1.4307

Information for order placements

Weight approx.: 61 kg
Item number: 29993568

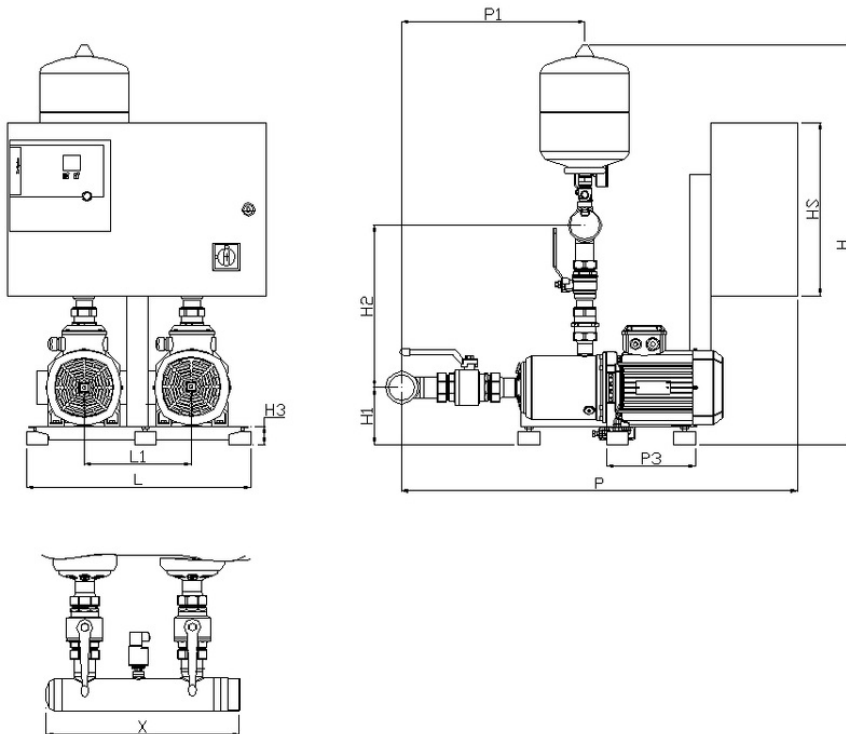

Dimensions mm

DNd	R 2, PN 1	H3	85	P	1,017
DNs	R 2, PN 1	HS	600	P1	416
H	1,020	L	600	P3	300
H1	180	L1	250	X	430
H2	376	LS	600		

Contact
E-mail
Phone

Customer

Contact
E-mail
Phone

Dimensions

Multi-pump system

Isar MODH1-2CH1-L-1005/SCe

Project ID

Untitled project 2025-03-03 22:14:23.954

Project name

Installation location

Customer pos. No.

Date 2025-03-03

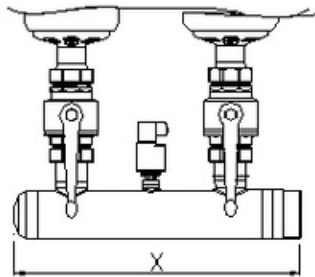
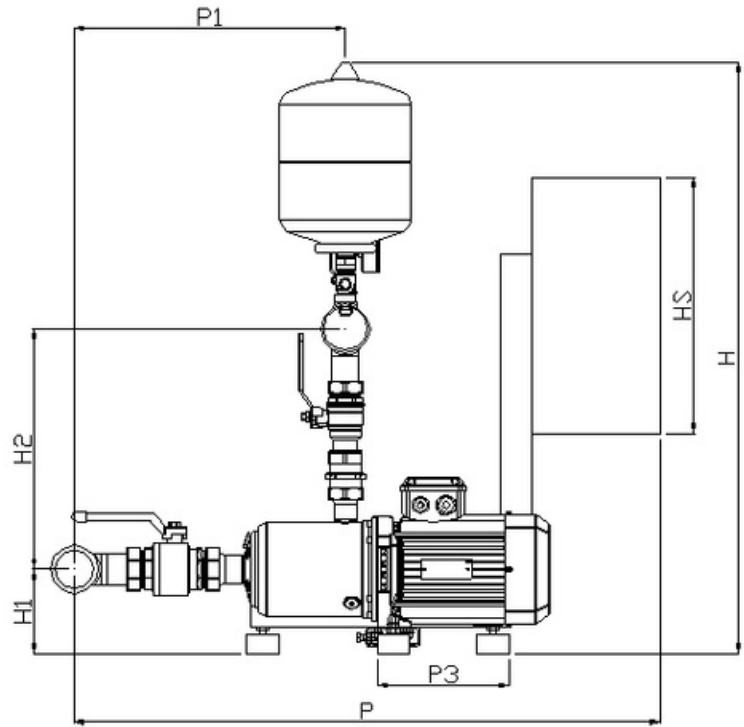
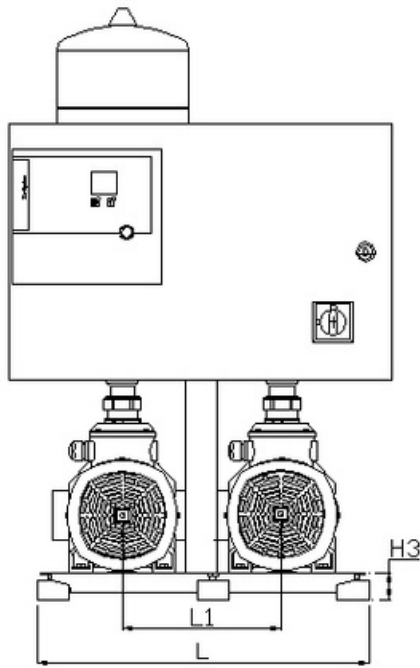

Standard

Suction side R 2, PN 10

Discharge side R 2, PN 10

Dimensions mm

Name	Value	Name	Value	Name	Value	Name	Value
DNd	R 2, PN 10	L	600				
DNs	R 2, PN 10	L1	250				
H	1,020	LS	600				
H1	180	P	1,017				
H2	376	P1	416				
H3	85	P3	300				
HS	600	X	430				