

**Customer**

## Technical data

Glanded standard pump  
Atmos GIGA-N 80/160-45/2/6

Project ID                      Untitled project 2025-03-05 00:23:19.113

Project name  
Installation location  
Customer pos. No.

Date                      2025-03-05

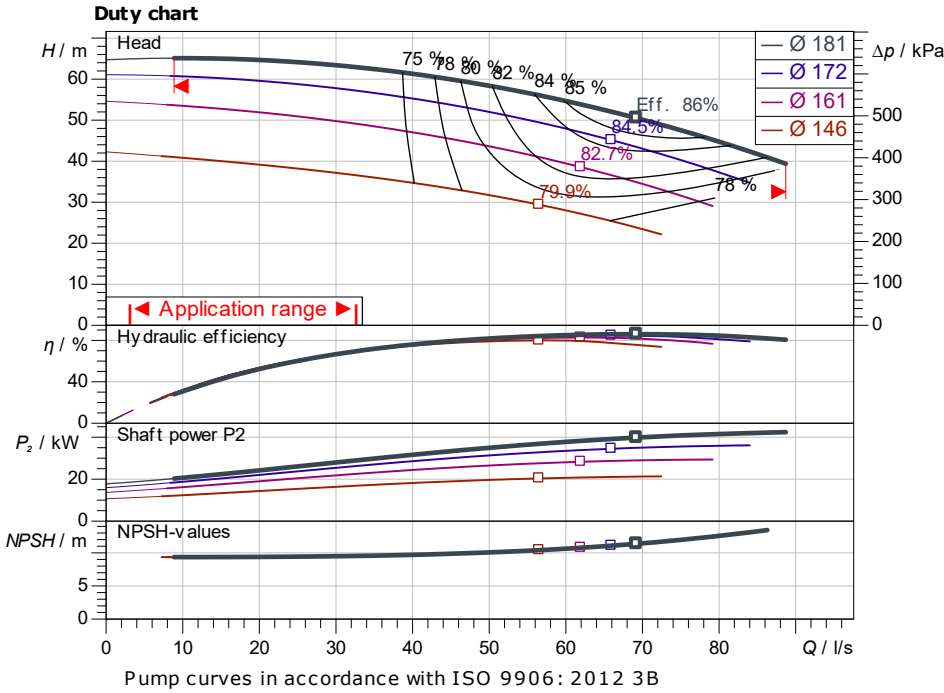

**Requested data**

Flow  
Head  
Media                      Water 100 %  
Fluid temperature       20.00 °C  
Density                    998.30 kg/m<sup>3</sup>  
Kin. viscosity             1.00 mm<sup>2</sup>/s

**Hydraulic data (Duty point)**

Flow  
Head  
Shaft power  $P_2$   
Hydraulic efficiency  
NPSH  
Impeller size             181

**Product data**

Glanded standard pump  
Atmos GIGA-N 80/160-45/2/6  
Max. operating pressure   1,600 kPa  
Fluid temperature       -20 °C ... +140 °C  
Max. ambient temperature  40 °C  
Minimum efficiency index (MEI)  $\geq 0.4$

**Motordata per Motor/Pump**

Motor efficiency level     IE3  
Mains connection         3~ 380 V / 60 Hz  
Permitted voltage tolerance  $\pm 10 \%$   
Max. speed                3,565 1/min  
Rated power  $P_2$          45.00 kW  
Rated current             81.20 A  
Power factor              0.9  
Efficiency  
50% / 75% / 100%       92.6/93.6/93.6%  
Degree of protection     IP55  
Insulation class         F  
Motor protection         No

**Fitting dimensions**

Pipe connection on the suction side DN 100, PN 16  
Pipe connection (pressure side) DN 80, PN 16  
Port to Port

**Materials**

Pump housing             5.1301/EN-GJL-250  
  
Impeller                 EN-GJL-200  
Lantern                 5.1301/EN-GJL-250  
Shaft                    1.4021  
Shaft seal               AQ1EGG

**Information for order placements**

Weight approx.         671 kg  
Item number

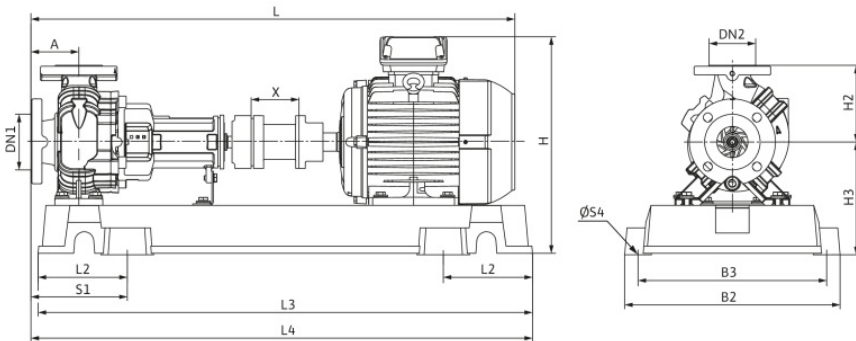

**Dimensions**

mm

A	125	H	712	L3	1,440
B2	610	H2	225	L4	1,470
B3	550	H3	328	S1	280
DN1	DN 100, L	L	1,481	S4	29
DN2	DN 80, P	L2	250	X	140



Contact  
E-mail  
Phone

Customer

Contact  
E-mail  
Phone

# Hydraulic data

Glanded standard pump  
Atmos GIGA-N 80/160-45/2/6

Project ID: Untitled project 2025-03-05 00:23:19.113

Project name  
Installation location  
Customer pos. No.

Date: 2025-03-05

## Operating data

Rotational speed <b>3480 1/min</b>	Frequency <b>60 Hz</b>	Duty point <b>Q =</b>	<b>H =</b>	Suction port <b>DN 100</b>	Discharge port <b>DN 80</b>
---------------------------------------	---------------------------	--------------------------	------------	-------------------------------	--------------------------------

Power data referred to: Water; 20°C; 998.3kg/m³; 1.005mm²/s ±10 % tolerance with linear U/f frequency control

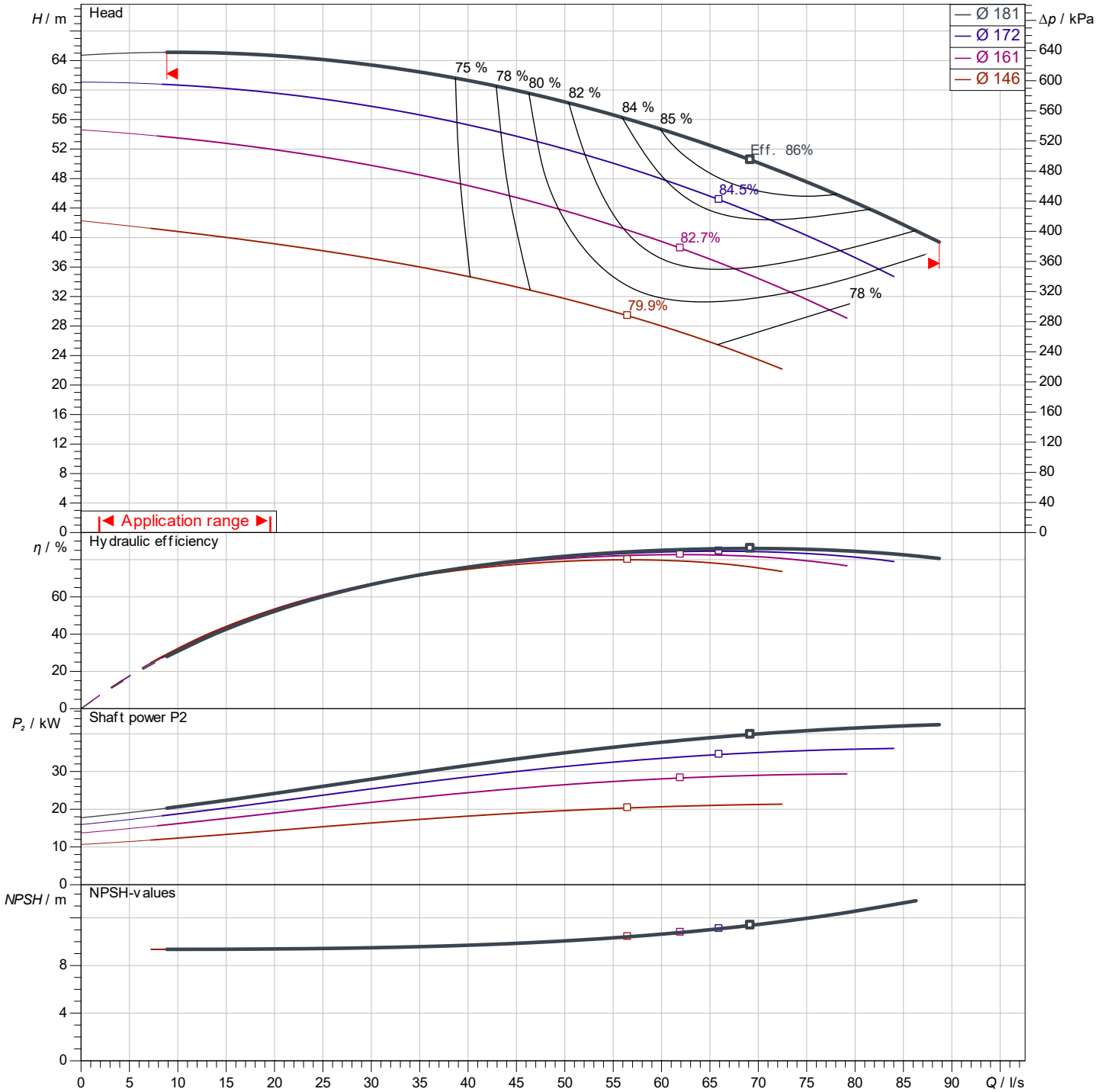

Pump curves in accordance with ISO 9906: 2012 3B

Contact  
E-mail  
Phone

**Customer**

Contact  
E-mail  
Phone

## Dimensions

Glanded standard pump  
Atmos GIGA-N 80/160-45/2/6

Project ID                      Untitled project 2025-03-05 00:23:19.113

Project name  
Installation location  
Customer pos. No.

Date                      2025-03-05



Coupling with spacer

Suction side                      DN 100, PN 16  
Discharge side                      DN 80, PN 16

**Dimensions**                      mm

Name	Value	Name	Value	Name	Value	Name	Value
A	125	H3	328	X	140		
B2	610	L	1,481				
B3	550	L2	250				
DN1	DN 100, PN 16	L3	1,440				
DN2	DN 80, PN 16	L4	1,470				
H	712	S1	280				
H2	225	S4	29				