

Customer

Technical data

Glanded standard pump Atmos GIGA-NHT 65/160-9/2-S2

Project ID Untitled project 2025-03-01 20:45:47.557

Project name
Installation location
Customer pos. No.

Date 2025-03-01

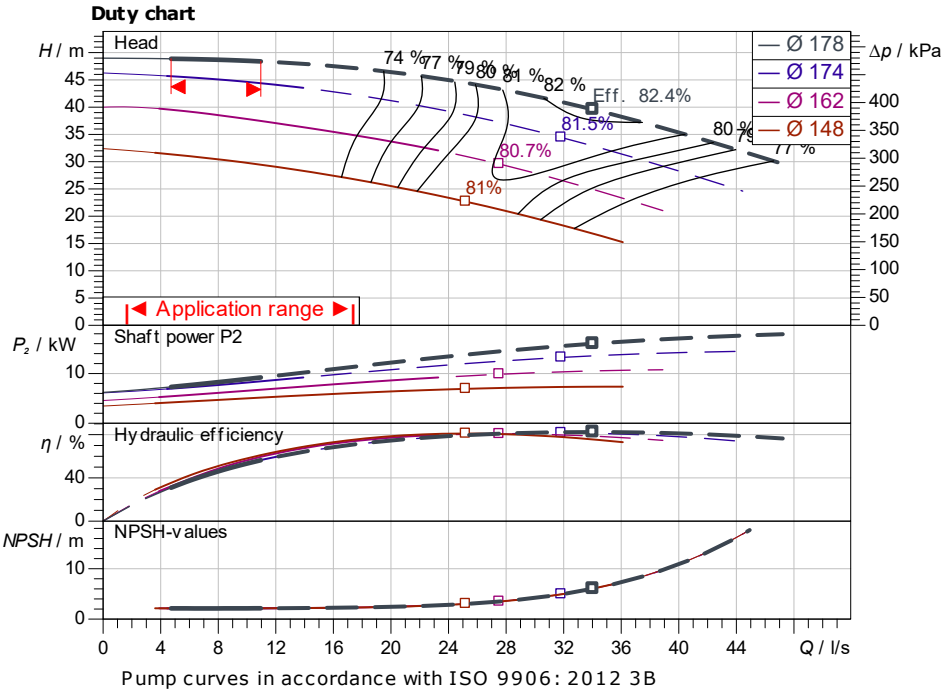

Requested data

Flow
Head
Media Water 100 %
Fluid temperature 20.00 °C
Density 998.30 kg/m³
Kin. viscosity 1.00 mm²/s

Hydraulic data (Duty point)

Flow
Head
Shaft power P_2
Hydraulic efficiency
NPSH
Impeller size 178

Product data

Glanded standard pump
Atmos GIGA-NHT 65/160-9/2-S2
Max. operating pressure 2,500 kPa
Fluid temperature -20 °C ... +350 °C
Max. ambient temperature 50 °C
Minimum efficiency index (MEI)

Motordata per Motor/Pump

Motor efficiency level IE3
Mains connection 3~ 400 V / 50 Hz
Permitted voltage tolerance +10 %
Max. speed 3,000 1/min
Rated power P_2 9.20 kW
Rated current
Power factor
Efficiency
50% / 75% / 100% //%
Degree of protection IP55
Insulation class F
Motor protection PTC

Fitting dimensions

Pipe connection on the suction side DN 80, PN 25
Pipe connection (pressure side) DN 65, PN 25
Port to Port

Materials

Pump housing EN-GJS-400-15

Impeller EN-GJL-200
Shaft 1.4028
Shaft seal AQ1VGG

Information for order placements

Weight approx.
Item number 6098363

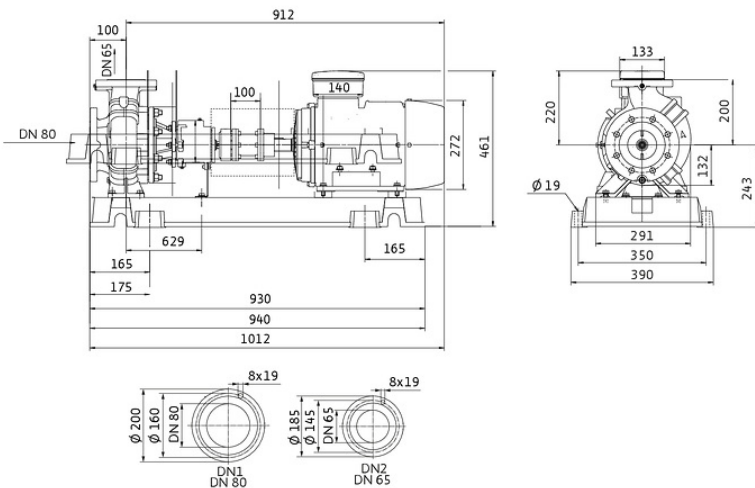

Dimensions mm



Contact
E-mail
Phone

Customer

Contact
E-mail
Phone

Hydraulic data

Glanded standard pump
Atmos GIGA-NHT 65/160-9/2-S2

Project ID: Untitled project 2025-03-01 20:45:47.557

Project name
Installation location
Customer pos. No.

Date: 2025-03-01

Operating data

Rotational speed 2955 1/min	Frequency 50 Hz	Duty point Q =	H =	Suction port DN 80	Discharge port DN 65
---------------------------------------	---------------------------	--------------------------	------------	------------------------------	--------------------------------

Power data referred to: Water; 20°C; 998.3kg/m³; 1.005mm²/s ±10 % tolerance with linear U/f frequency control

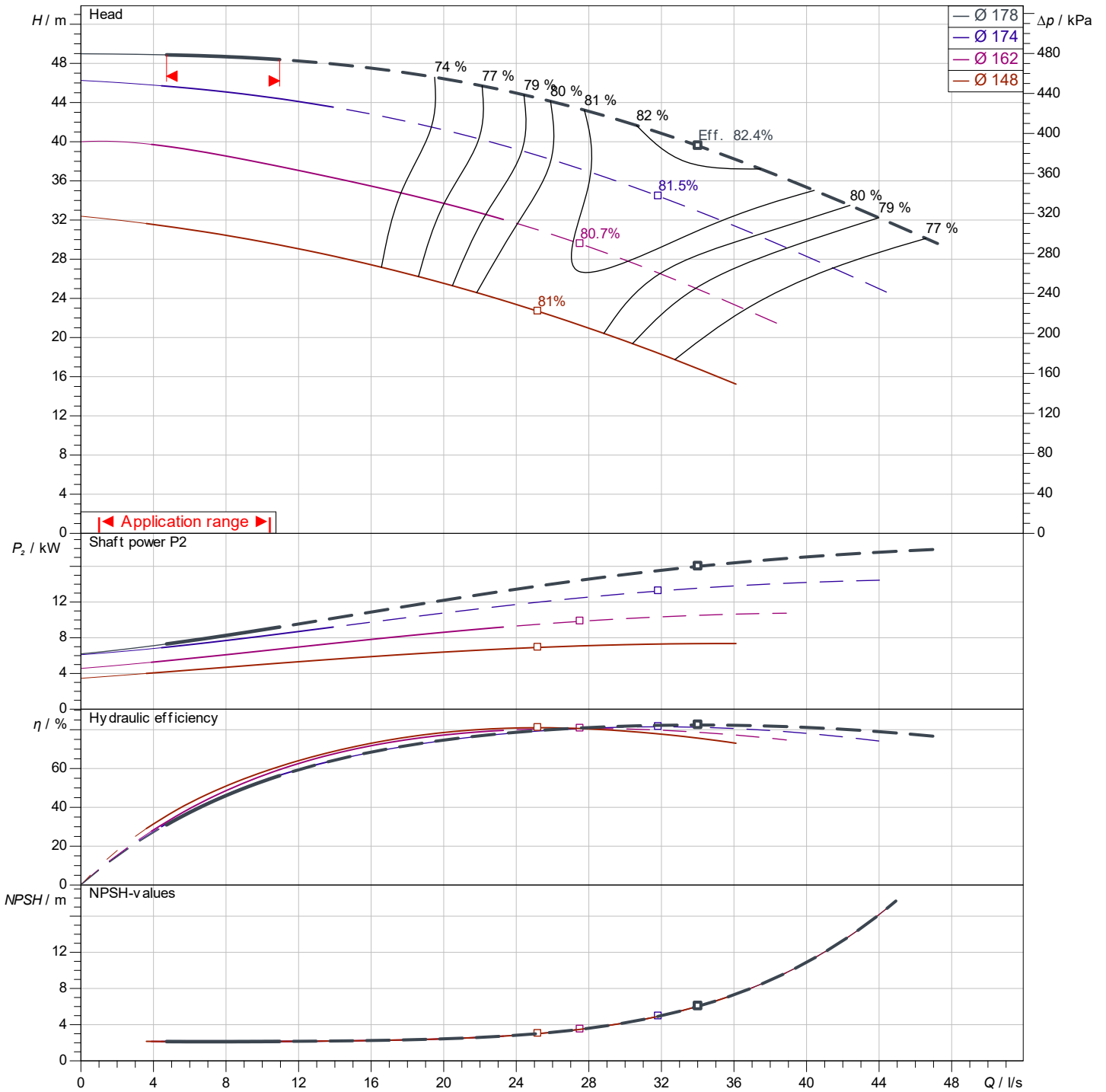

Pump curves in accordance with ISO 9906: 2012 3B

Contact
E-mail
Phone

Customer

Contact
E-mail
Phone

Dimensions

Glanded standard pump
Atmos GIGA-NHT 65/160-9/2-S2

Project ID Untitled project 2025-03-01 20:45:47.557

Project name
Installation location
Customer pos. No.

Date 2025-03-01

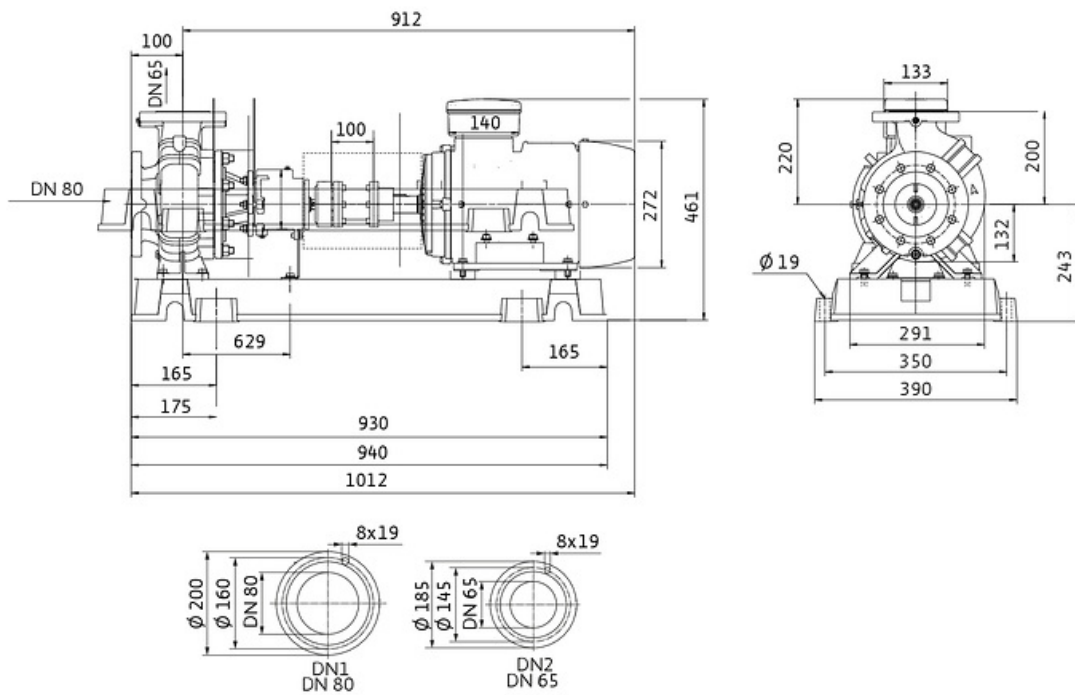

Standard

Suction side DN 80, PN 25

Discharge side DN 65, PN 25

Dimensions mm

Name	Value	Name	Value	Name	Value	Name	Value
------	-------	------	-------	------	-------	------	-------