

**Customer**

## Technical data

### Glanded standard pump Atmos GIGA-N 50/160-B

Project ID: Untitled project 2025-03-01 20:23:09.313

Project name  
Installation location  
Customer pos. No.

Date: 2025-03-01

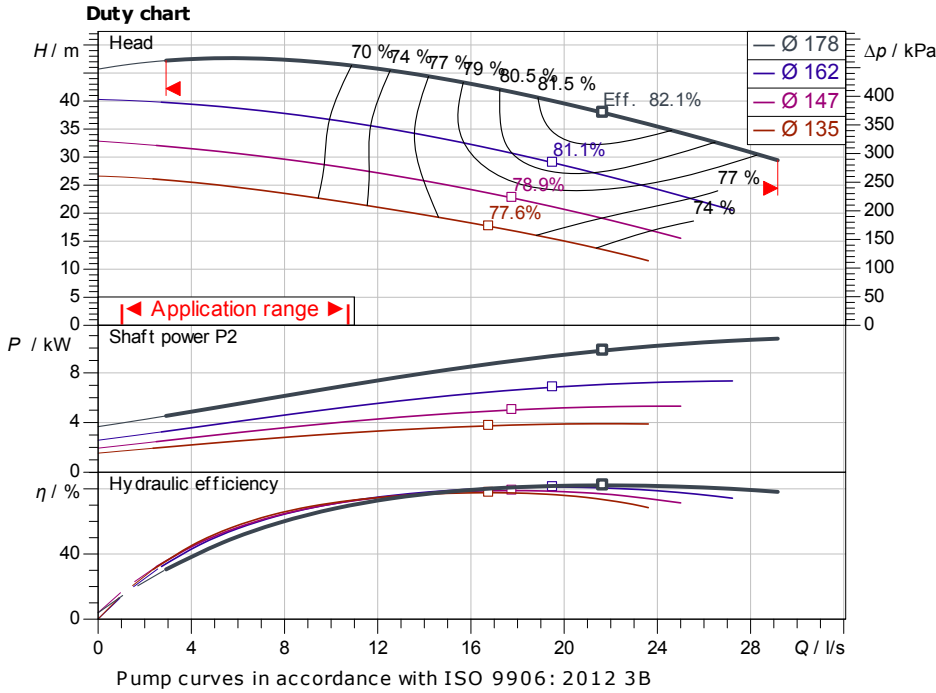

#### Requested data

Flow  
Head  
Media: Water 100 %  
Fluid temperature: 20.00 °C  
Density: 998.30 kg/m<sup>3</sup>  
Kin. viscosity: 1.00 mm<sup>2</sup>/s

#### Hydraulic data (Duty point)

Flow  
Head  
Shaft power  $P_2$   
Hydraulic efficiency  
NPSH  
Impeller size: 178

#### Product data

Glanded standard pump  
Atmos GIGA-N 50/160-B  
Max. operating pressure: 1,600 kPa  
Fluid temperature: -20 °C ... +140 °C  
Max. ambient temperature: 40 °C  
Minimum efficiency index (MEI)

#### Motor data per Motor/Pump

Motor efficiency level  
Mains connection: V / Hz  
Permitted voltage tolerance  
Max. speed  
Rated power  $P_2$   
Rated current  
Power factor  
Efficiency: 50% / 75% / 100% // %  
Degree of protection  
Insulation class  
Motor protection

#### Fitting dimensions

Pipe connection on the suction side: DN 65, PN 16  
Pipe connection (pressure side): DN 50, PN 16  
Port to Port

#### Materials

Pump housing: 5.1301/EN-GJL-250  
Impeller: EN-GJL-200  
Lantern: 5.1301/EN-GJL-250  
Shaft: 1.4021  
Shaft seal: AQ1EGG

#### Information for order placements

Weight approx.  
Item number: 6090533

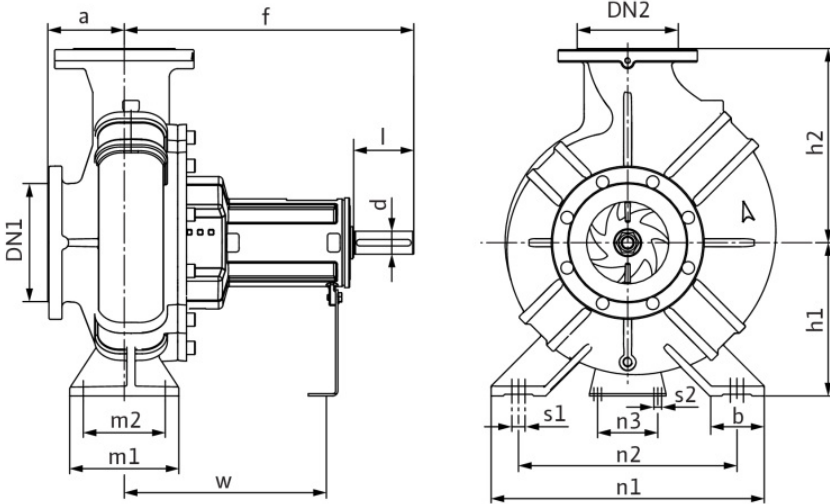

#### Dimensions

mm

a	100	DN2	DN 50, P	h2	180	n2	212
b	50	f	360	l	50	n3	110
d	24	h1	160	m1	100	Ø k	145
dL	19	h1	160	m2	70	Ø d	118
DN1	DN 65, P	h2	180	n1	265	Ø D	185



Contact  
E-mail  
Phone

**Customer**

Contact  
E-mail  
Phone

## Hydraulic data

Glanded standard pump  
Atmos GIGA-N 50/160-B

Project ID                      Untitled project 2025-03-01 20:23:09.313

Project name  
Installation location  
Customer pos. No.

Date                      2025-03-01

## Operating data

Rotational speed <b>2955 1/min</b>	Frequency <b>Hz</b>	Duty point <b>Q =</b>	<b>H =</b>	Suction port <b>DN 65</b>	Discharge port <b>DN 50</b>
---------------------------------------	------------------------	--------------------------	------------	------------------------------	--------------------------------

Power data referred to:                      Water; 20°C; 998.3kg/m<sup>3</sup>; 1.005mm<sup>2</sup>/s                      ±10 % tolerance with linear U/f frequency control

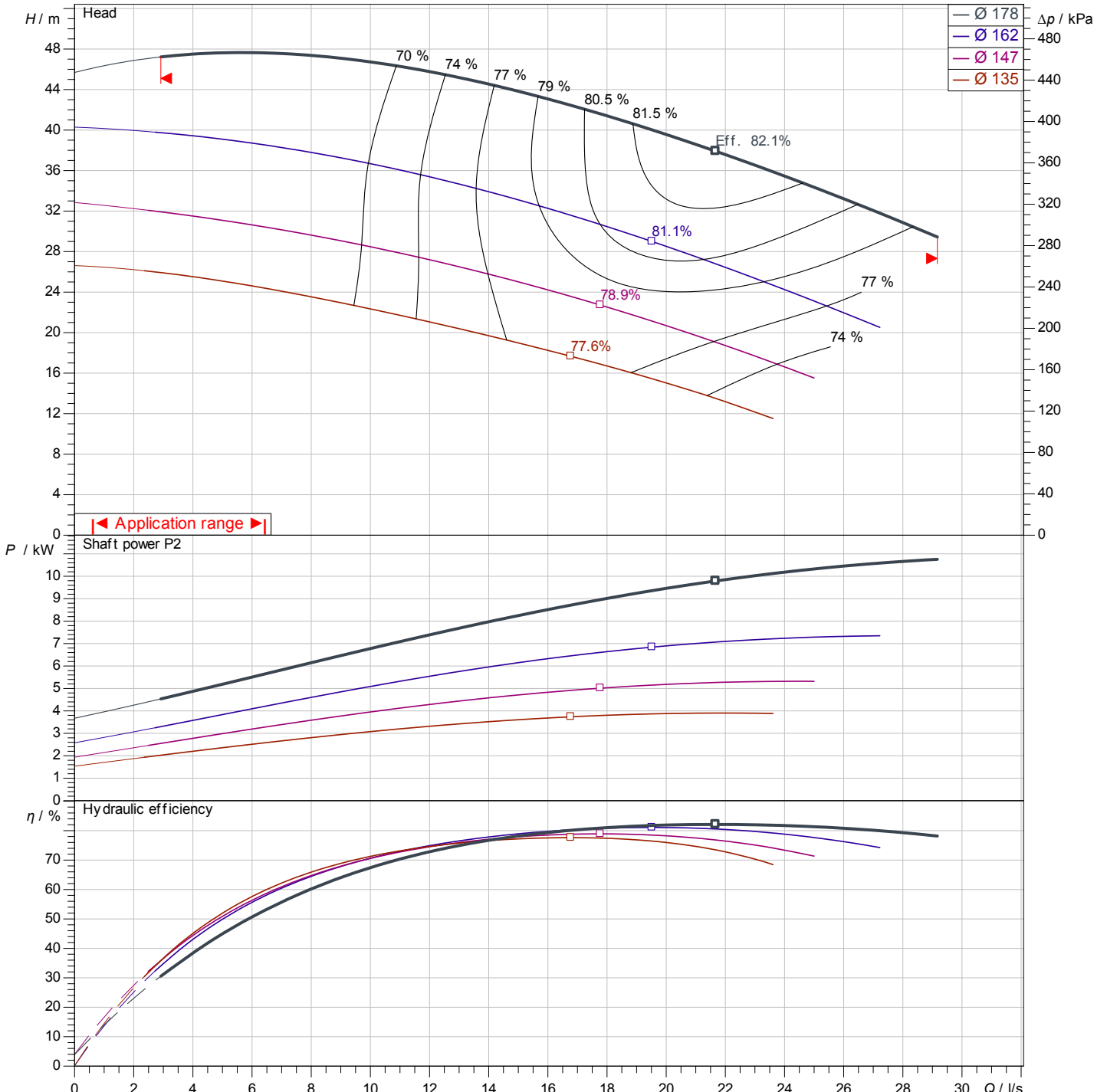

Pump curves in accordance with ISO 9906: 2012 3B

**Customer**

## Dimensions

Glanded standard pump  
Atmos GIGA-N 50/160-B

Project ID                      Untitled project 2025-03-01 20:23:09.313

Project name  
Installation location  
Customer pos. No.

Date                      2025-03-01

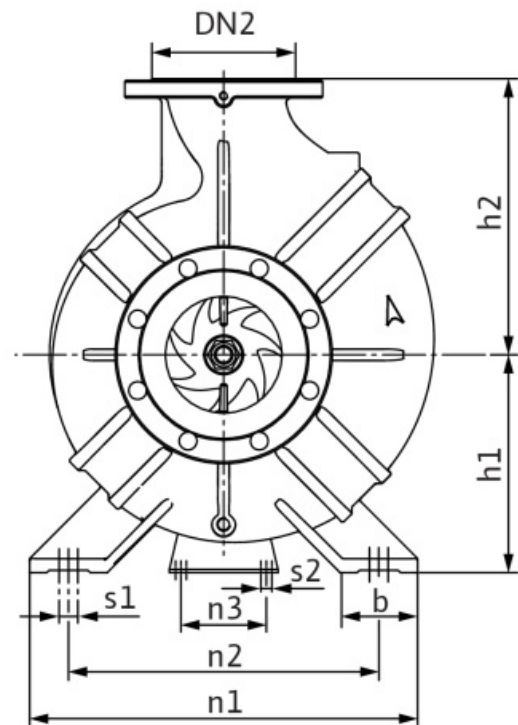
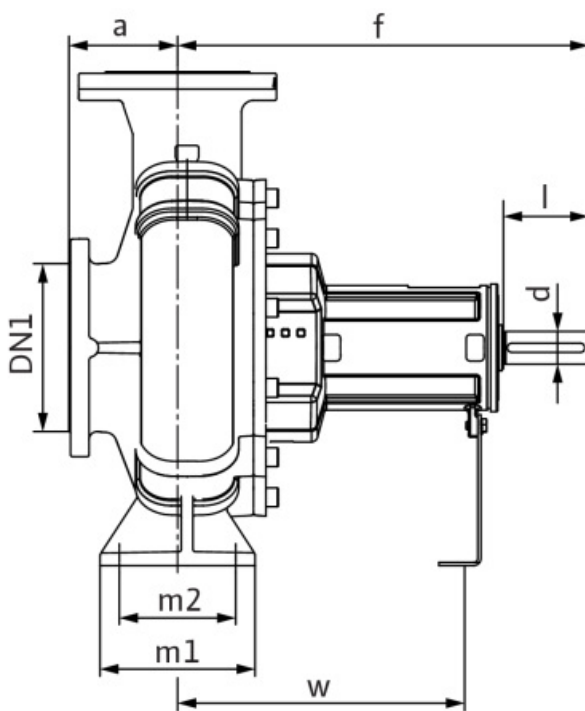

**Bareshaft**

Suction side                      DN 65, PN 16  
Discharge side                      DN 50, PN 16

**Dimensions**                      mm

Name	Value	Name	Value	Name	Value	Name	Value
a	100	h1	160	n1	265	s2	12
b	50	h1	160	n2	212	w	260
d	24	h2	180	n3	110	x	100
dL	19	h2	180	Ø k	145		
DN1	DN 65, PN 16	l	50	Ø d	118		
DN2	DN 50, PN 16	m1	100	Ø D	185		
f	360	m2	70	s1	12		