

Customer

Technical data

Glanded monobloc pump Atmos BST 50/125-2.2/2-H12-V1

Project ID: Untitled project 2025-03-01 17:12:44.130

Project name
Installation location
Customer pos. No.

Date: 2025-03-01

Duty chart

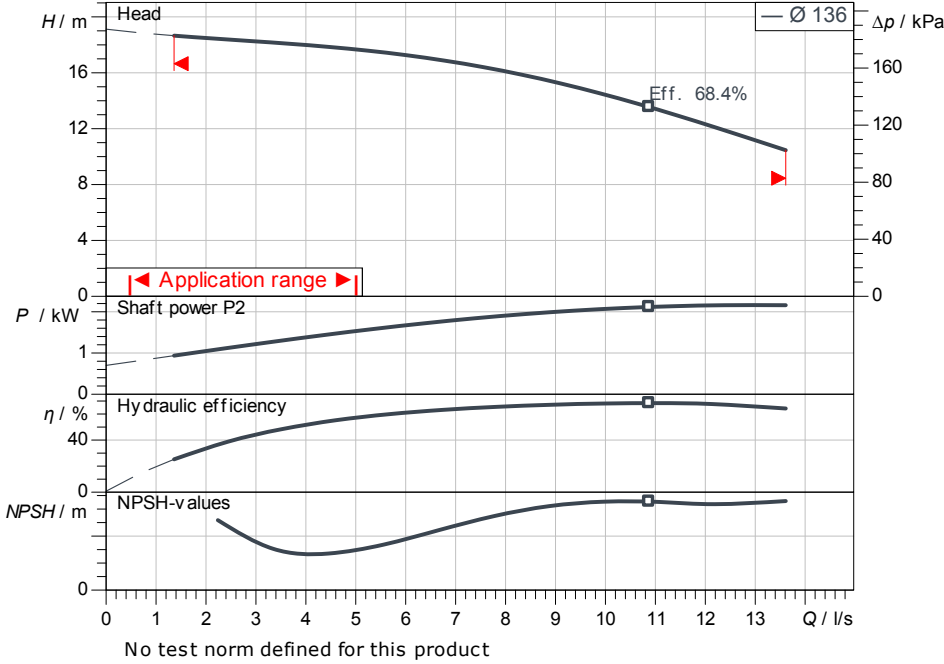

Requested data

Flow	
Head	
Media	Water 100 %
Fluid temperature	20.00 °C
Density	998.30 kg/m ³
Kin. viscosity	1.00 mm ² /s

Hydraulic data (Duty point)

Flow	
Head	
Shaft power P2	
Hydraulic efficiency	
NPSH	
Impeller size	136

Product data

Glanded monobloc pump	
Atmos BST 50/125-2.2/2-H12-V1	
Max. operating pressure	1,000 kPa
Fluid temperature	-20 °C ... +120 °C
Max. ambient temperature	50 °C
Minimum efficiency index (MEI)	≥ 0.4

Motordata per Motor/Pump

Motor efficiency level	IE3
Mains connection	3~ 400 V / 50 Hz
Permitted voltage tolerance	+6 %
Max. speed	2,900 1/min
Rated power P2	2.20 kW
Rated current	4.30 A
Power factor	0.85
Efficiency	50% / 75% / 100%
Degree of protection	IP55
Insulation class	F
Motor protection	

Fitting dimensions

Pipe connection on the suction side	DN 65, PN 16
Pipe connection (pressure side)	DN 50, PN 16
Port to Port	

Materials

Pump housing	1.4401
Impeller	1.4401
Shaft	1.4401
Shaft seal	B3Q1EG

Information for order placements

Weight approx.	
Item number	9187155

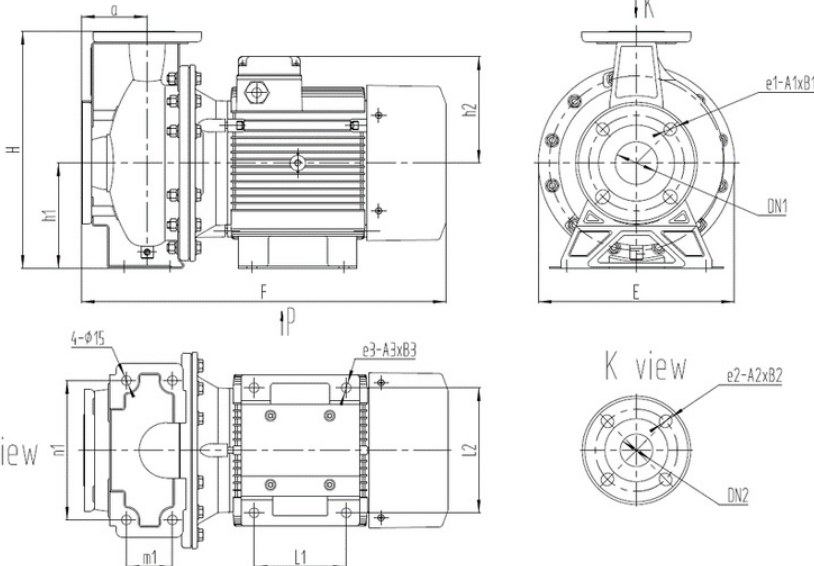

Dimensions

mm

A	80	B2	20	E	256	L1	100
A1	18	B3	18	F	436	L2	160
A2	18	dL	18	H	292	M1	70
A3	12	DN1	DN 65, P	H1	132	n1	190
B1	20	DN2	DN 50, P	H2	112	Ø k	145

Hydraulic data

Glanded monobloc pump
Atmos BST 50/125-2.2/2-H12-V1

Project ID: Untitled project 2025-03-01 17:12:44.130

Project name
Installation location
Customer pos. No.

Date: 2025-03-01

Operating data

Rotational speed 2887 1/min	Frequency 50 Hz	Duty point Q =	H =	Suction port DN 65	Discharge port DN 50
---------------------------------------	---------------------------	--------------------------	------------	------------------------------	--------------------------------

Power data referred to: Water; 20°C; 998.3kg/m³; 1.005mm²/s ±10 % tolerance with linear U/f frequency control

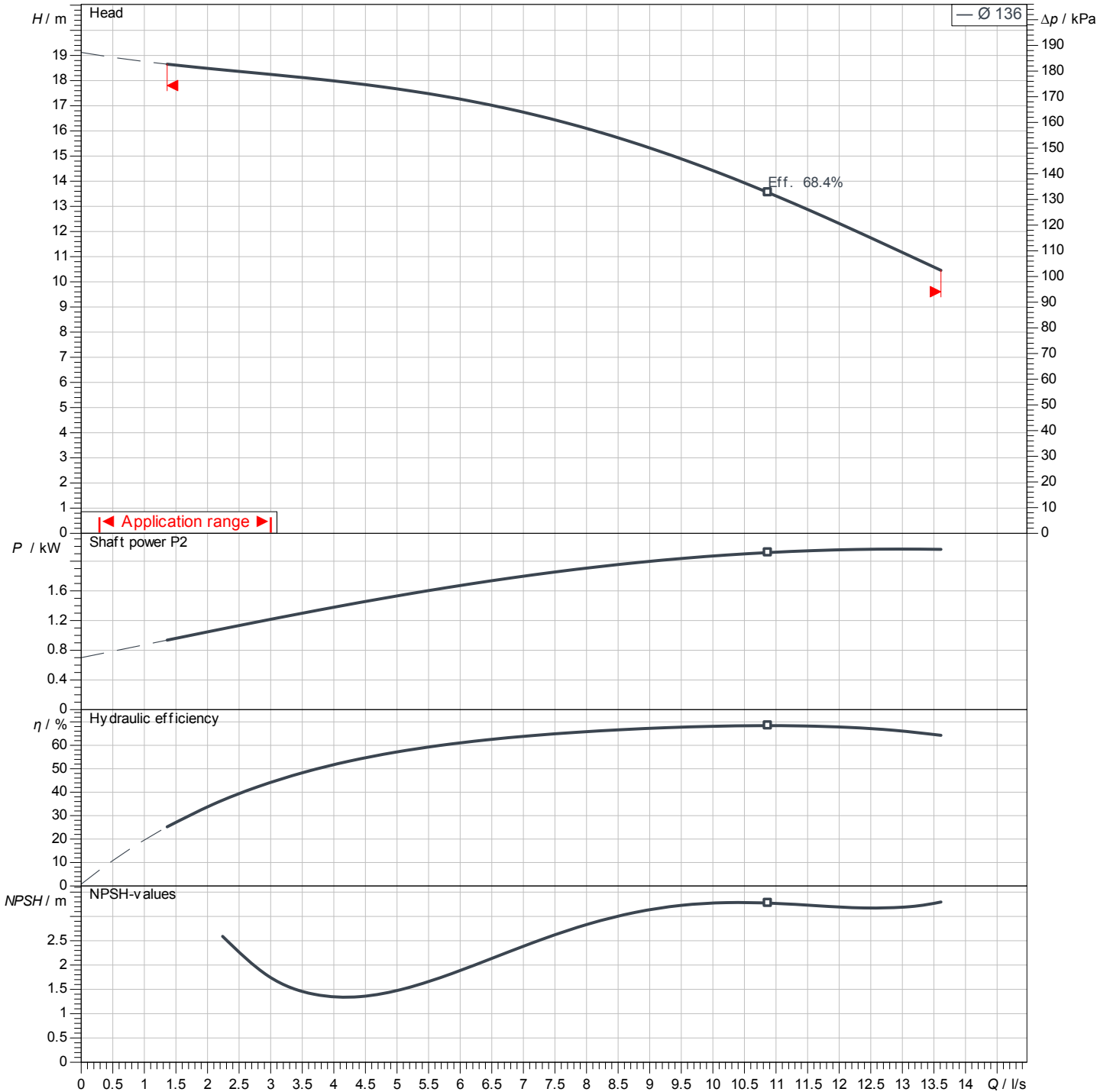

No test norm defined for this product

Contact
E-mail
Phone

Customer

Contact
E-mail
Phone

Dimensions

Glanded monobloc pump
Atmos BST 50/125-2.2/2-H12-V1

Project ID Untitled project 2025-03-01 17:12:44.130

Project name
Installation location
Customer pos. No.

Date 2025-03-01

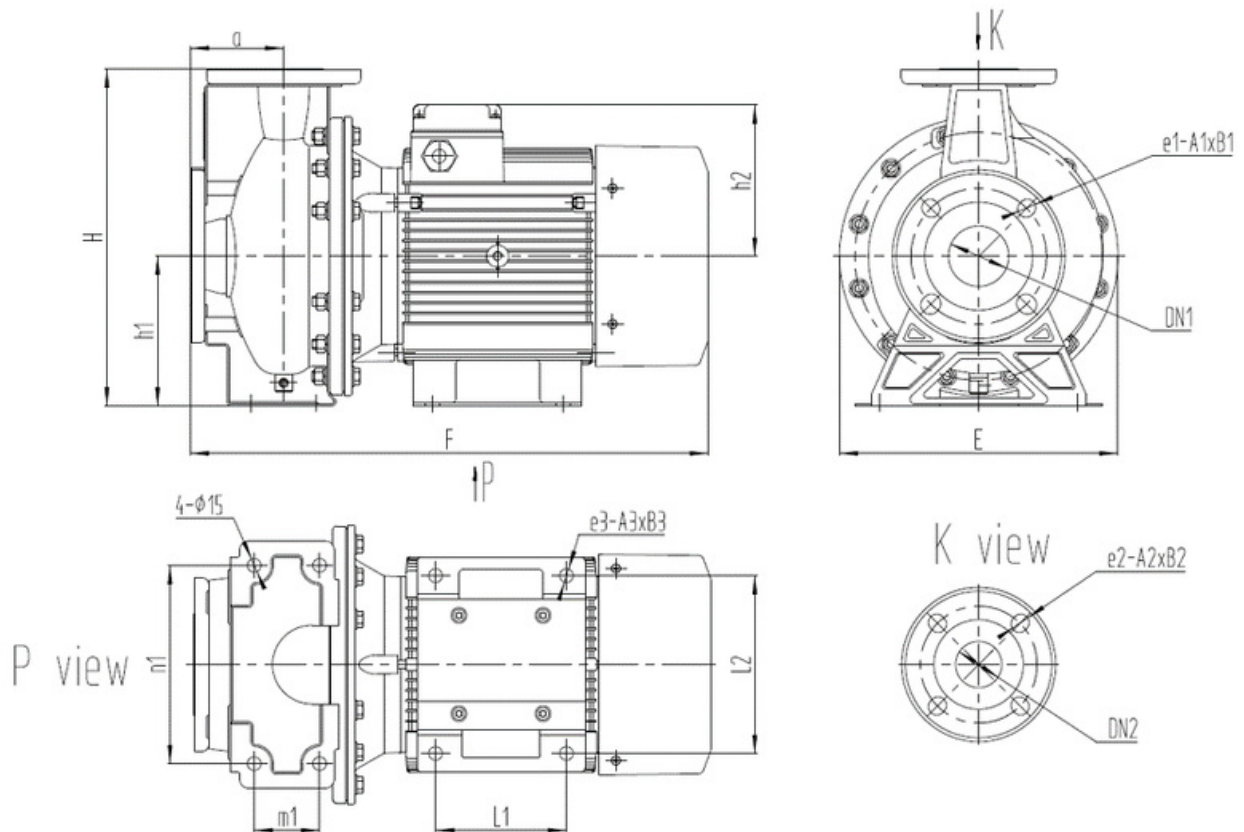

Standard

Suction side DN 65, PN 16
Discharge side DN 50, PN 16

Dimensions mm

Name	Value	Name	Value	Name	Value	Name	Value
A	80	dL	18	H2	112	Ø D	185
A1	18	DN1	DN 65, PN 16	L1	100		
A2	18	DN2	DN 50, PN 16	L2	160		
A3	12	E	256	M1	70		
B1	20	F	436	n1	190		
B2	20	H	292	Ø k	145		
B3	18	H1	132	Ø d	108		