

**Customer**

## Technical data

### High-pressure multistage centrifugal pump Medana CV1-L.211-1/E/G/160

Project ID: Untitled project 2025-03-05 08:29:53.905

Project name  
Installation location  
Customer pos. No.

Date: 2025-03-05

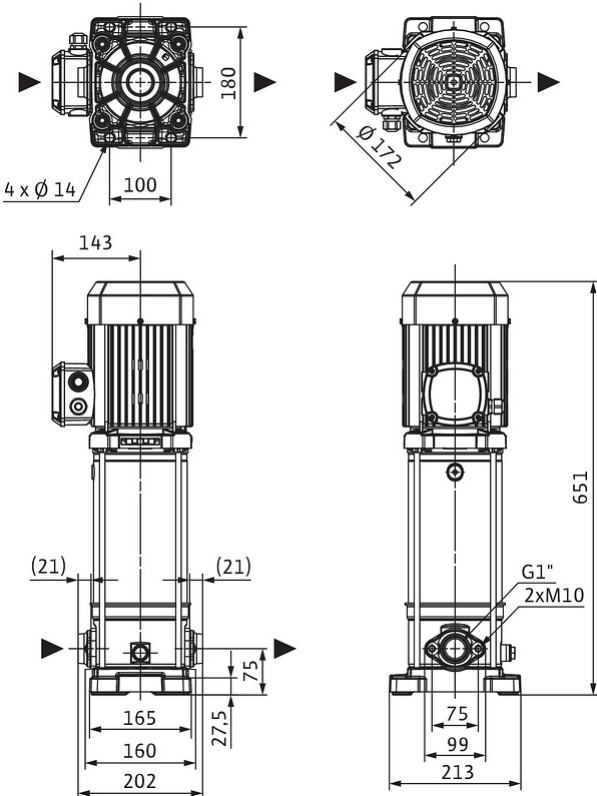
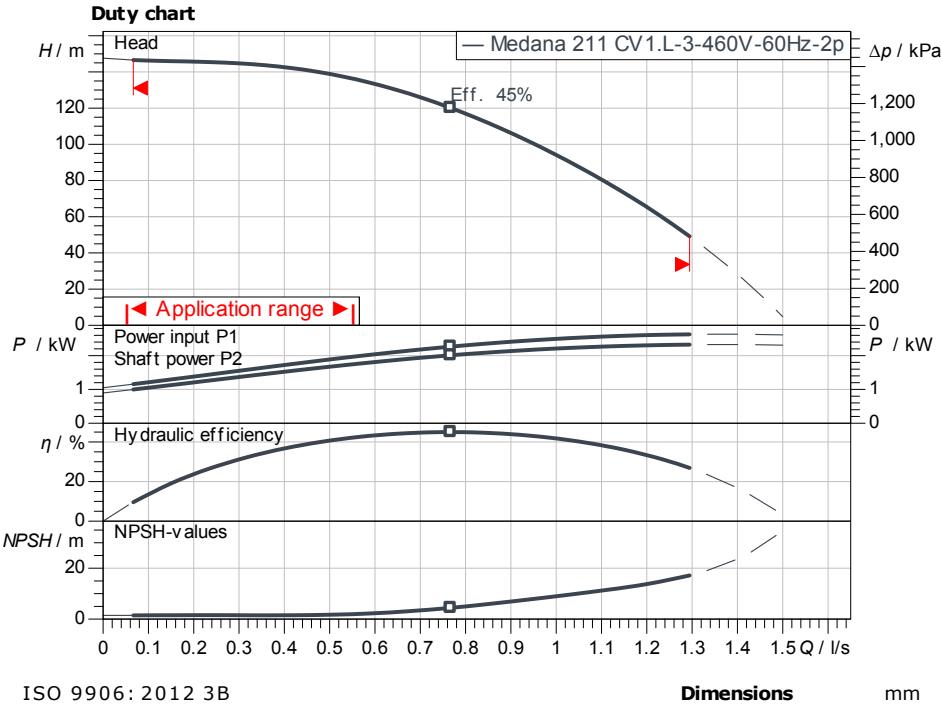

**Requested data**

Flow	
Head	
Media	Water 100 %
Fluid temperature	20.00 °C
Density	998.30 kg/m <sup>3</sup>
Kin. viscosity	1.00 mm <sup>2</sup> /s

**Hydraulic data (Duty point)**

Flow	
Head	
Shaft power P2	
Hydraulic efficiency	
NPSH	

**Product data**

High-pressure multistage centrifugal pump Medana CV1-L.211-1/E/G/160	
Max. operating pressure	1,600 kPa
Inlet pressure max.	6 bar
Fluid temperature	-20 °C ... +120 °C
Max. ambient temperature	50 °C
Minimum efficiency index (MEI)	≥ 0.7

**Motordata per Motor/Pump**

Motor efficiency level	
Mains connection	3~ 460 V / 60 Hz
Permitted voltage tolerance	+ -10 %
Rated speed	3,500 1/min
Rated power P2	2.50 kW
Rated current	4.50 A
Power factor	
Service factor	1.5
Degree of protection	IP55
Insulation class	F
Motor protection	No

**Fitting dimensions**

Pipe connection on the suction side	G 1, PN 16
Pipe connection (pressure side)	G 1, PN 16

**Materials**

Pump housing	1.4301
Impeller	1.4301
Shaft	1.4301
Shaft seal	BQ7EGG
Gasket material	EPDM

**Information for order placements**

Weight approx.	28.9 kg
Item number	4240484