

**Customer**

## Technical data

### Sewage lifting unit; Double-pump system DrainLift SANI CUT-L.42/T540/1-CEE

Project ID                      Untitled project 2025-03-03 09:36:10.883

Project name  
Installation location  
Customer pos. No.

Date                      2025-03-03

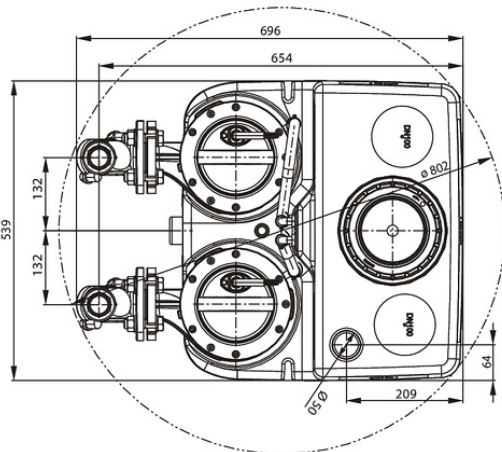
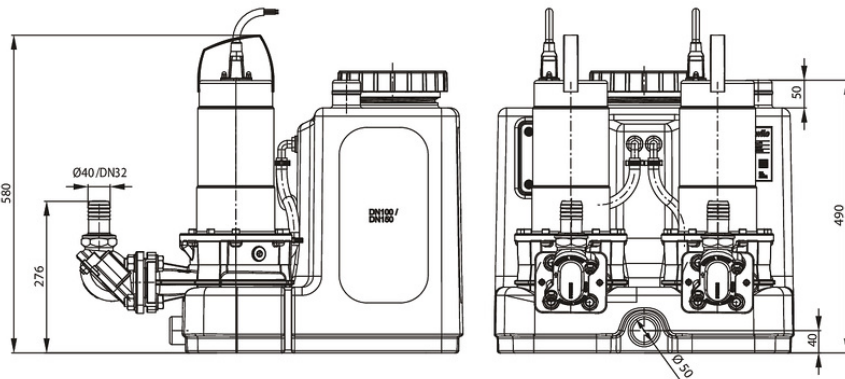
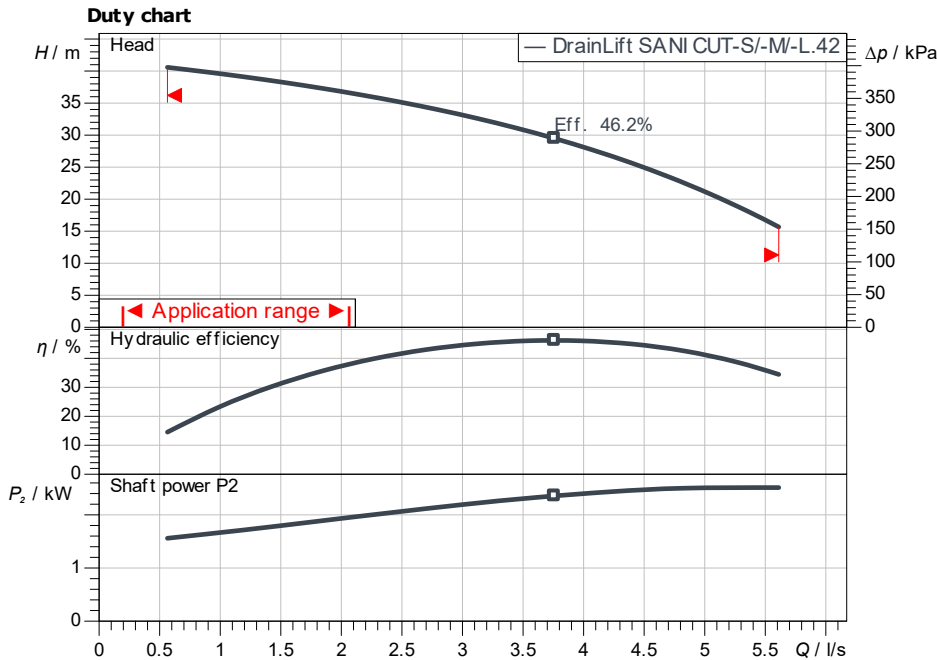

**Requested data**

Flow	
Head	
Media	Water 100 %
Fluid temperature	20.00 °C
Density	998.30 kg/m <sup>3</sup>
Kin. viscosity	1.00 mm <sup>2</sup> /s

**Hydraulic data (Duty point)**

Flow  
Head

**Product data**

Sewage lifting unit; Double-pump system DrainLift SANI CUT-L.42/T540/1-CEE	
No. of pumps	2
Max. operating pressure	600 kPa
Fluid temperature	3 °C ... +40 °C
Grinder	Yes
Operating mode (non-immersed)	S3-10%
Gross volume	64 l
Max. switching volume	0 l
Max. sound pressure level	70 dB
Free ball passage	10 mm

**Motordata per Motor/Pump**

Mains connection	3~ 400 V / 50 Hz
Permitted voltage tolerance	+10 %
Nominal speed	2,848 1/min
Rated power P2	2.50 kW
Power input P1	3.2 kW
Rated current	5.50 A
Activation type	Direct On Line (DOL)
Degree of protection	IP68
Motor protection	<b>Bi металл</b>
Insulation class	F
Schaltspiel	60

**Cable**

Length of connecting cable	4 m
Mains plug	CEE 16A, 3P+N+PE, 6P
Type of connection cable	Detachable
Cable type	H07RN-F
Cable cross section	6G1

**Fitting dimensions**

Venting	DN 50 (50 mm)
Pipe connection on the suction side	DN 110 (110 mm)
Pipe connection (pressure side)	DN 32

**Materials**

Tank	PE
Pump housing	5.1301/EN-GJL-250
Impeller	5.1301/EN-GJL-250
Shaft	1.4401
Motor housing	1.4301
Gasket material	NBR

**Information for order placements**

Weight approx.	104.5 kg
Item number	6095533

Contact  
E-mail  
Phone

**Customer**

Contact  
E-mail  
Phone

## Dimensions

Sewage lifting unit; Double-pump system  
DrainLift SANI CUT-L.42/T540/1-CEE

Project ID                      Untitled project 2025-03-03 09:36:10.883

Project name  
Installation location  
Customer pos. No.

Date                      2025-03-03

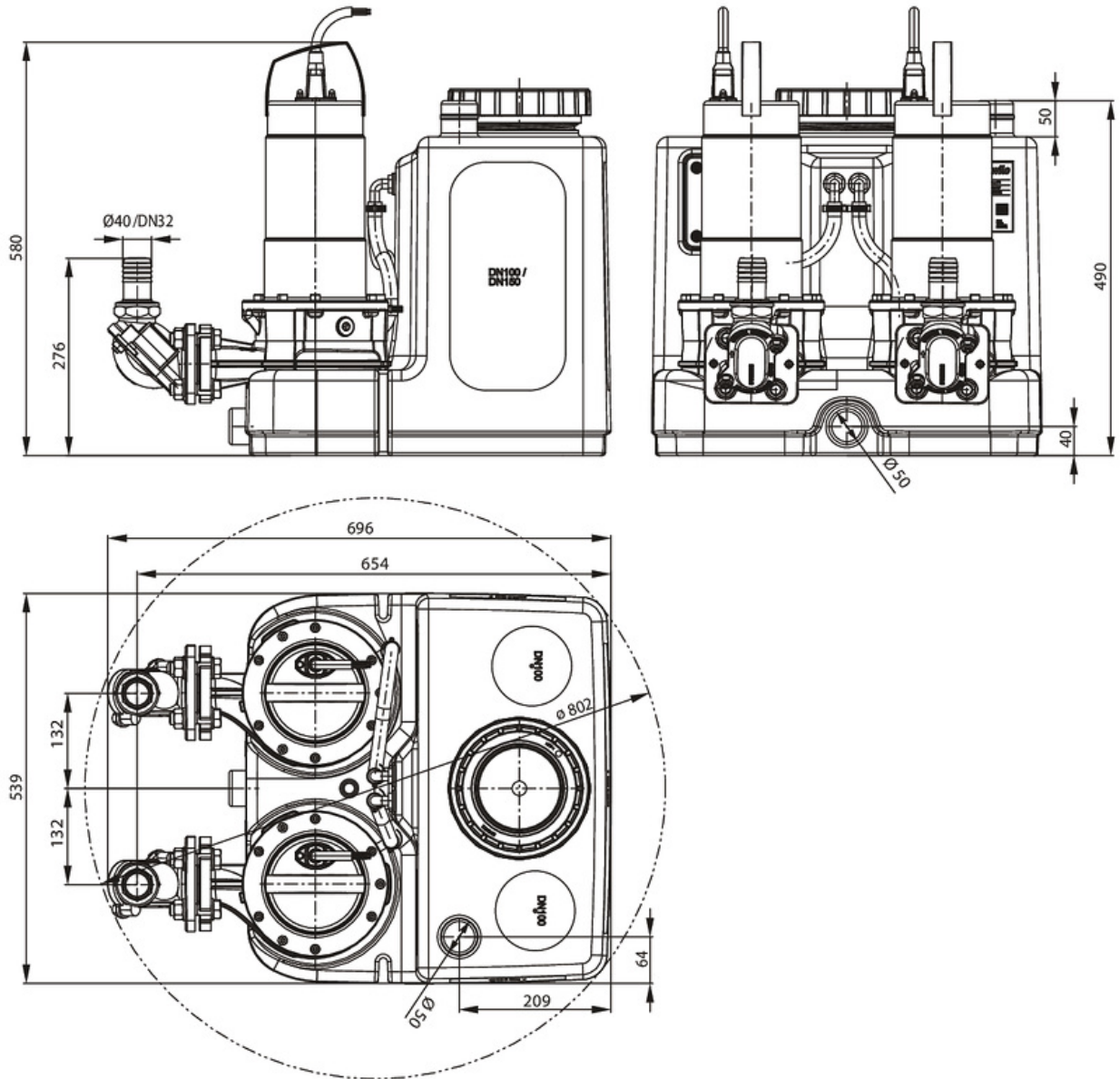

**Stationary dry well installation**

Suction side                      DN 110 (110 mm), PN 0,5/PN 6  
Discharge side                      DN 32, PN 0,5/PN 6

**Dimensions**                      mm

Name	Value	Name	Value	Name	Value	Name	Value
------	-------	------	-------	------	-------	------	-------