

**Customer**

## Technical data

### High-pressure multistage centrifugal pump MVI 7003/1-3/16/E/3-460-60-2

Project ID                      Untitled project 2025-03-05 08:57:18.785

Project name  
Installation location  
Customer pos. No.

Date                      2025-03-05

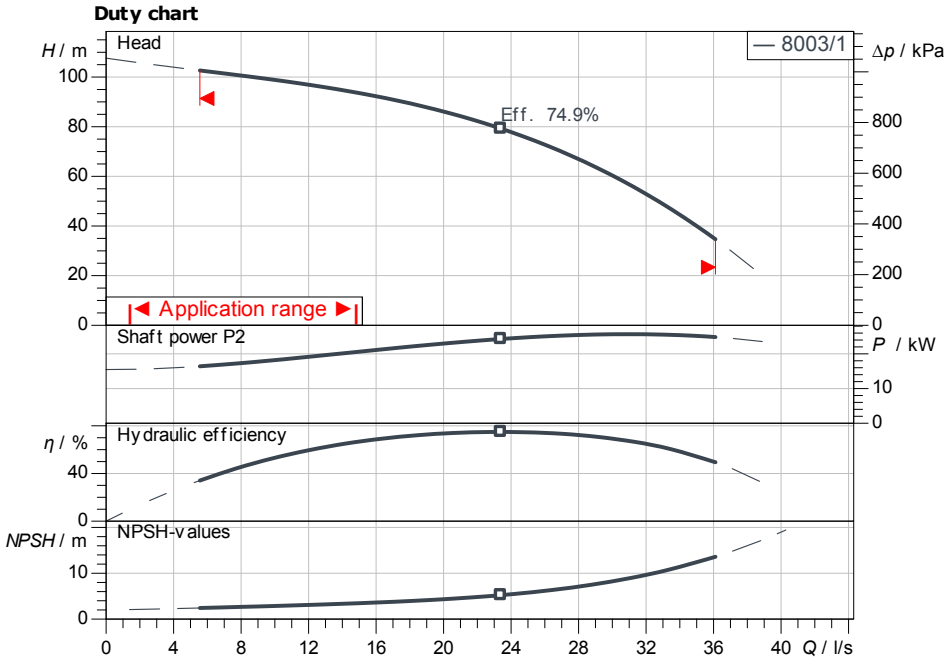

ISO 9906: 2012 3B

**Dimensions**

H	1,43
H2	842
$\varnothing M$	347
X	255

mm

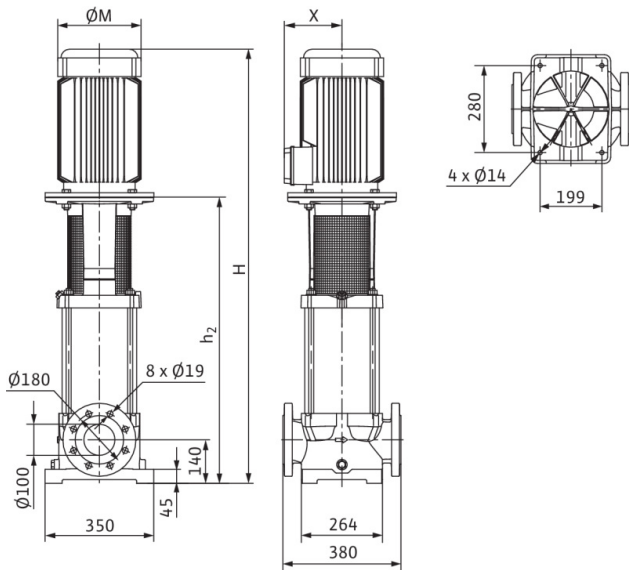

**Requested data**

Flow	
Head	
Media	Water 100 %
Fluid temperature	20.00 °C
Density	998.30 kg/m <sup>3</sup>
Kin. viscosity	1.00 mm <sup>2</sup> /s

**Hydraulic data (Duty point)**

Flow	
Head	
Shaft power $P_2$	
Hydraulic efficiency	
NPSH	

**Product data**

High-pressure multistage centrifugal pump MVI 7003/1-3/16/E/3-460-60-2	
Max. operating pressure	1,600 kPa
Inlet pressure max.	10 bar
Fluid temperature	-15 °C ... +120 °C
Max. ambient temperature	50 °C
Minimum efficiency index (MEI)	

**Motordata per Motor/Pump**

Motor efficiency level	IE3
Mains connection	3~ 460 V / 60 Hz
Permitted voltage tolerance	+6 %
Max. speed	3,560 1/min
Rated power $P_2$	30.00 kW
Rated current	45.80 A
Power factor	0.9
Service factor	1.15
Efficiency	
50% / 75% / 100%	//%
Degree of protection	IP55
Insulation class	F
Motor protection	No

**Fitting dimensions**

Pipe connection on the suction side	DN 100, PN 16
Pipe connection (pressure side)	DN 100, PN 16

**Materials**

Pump housing	5.1301/EN-GJL-250
Impeller	1.4408
Shaft	1.4057
Shaft seal	U3BE3GG
Gasket material	EPDM

**Information for order placements**

Weight approx.	287 kg
Item number	4082034