

Customer

Technical data

High-pressure multistage centrifugal pump Medana CV1-L.208-1/E/E/160

Project ID: Untitled project 2025-03-03 23:00:00.495

Project name
Installation location
Customer pos. No.

Date: 2025-03-03

Duty chart

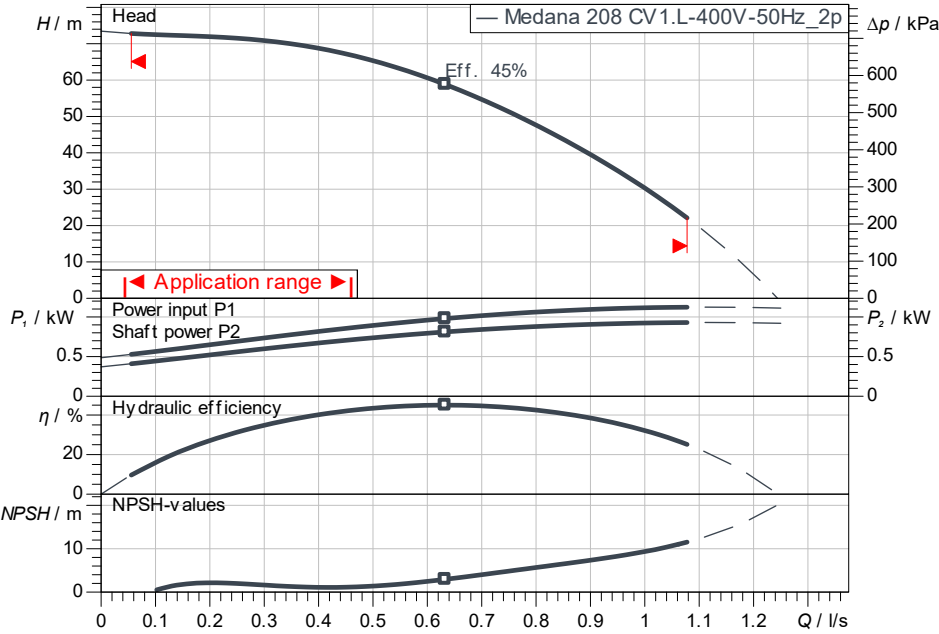

ISO 9906: 2012 3B

Dimensions

mm

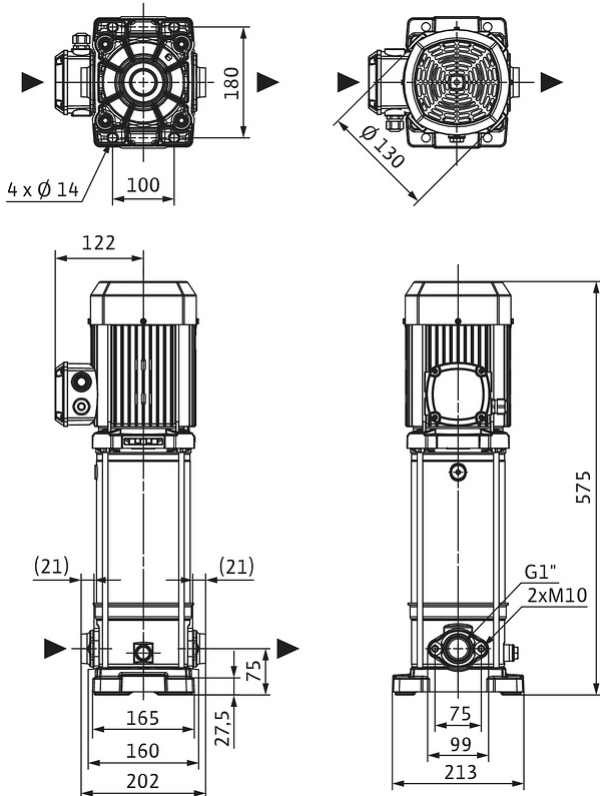

Requested data

Flow
Head
Media: Water 100 %
Fluid temperature: 20.00 °C
Density: 998.30 kg/m³
Kin. viscosity: 1.00 mm²/s

Hydraulic data (Duty point)

Flow
Head
Shaft power P2
Hydraulic efficiency
NPSH

Product data

High-pressure multistage centrifugal pump
Medana CV1-L.208-1/E/E/160
Max. operating pressure: 1,600 kPa
Inlet pressure max.: 6 bar
Fluid temperature: -20 °C ... +120 °C
Max. ambient temperature: 50 °C
Minimum efficiency index (MEI): ≥ 0.7

Motordata per Motor/Pump

Motor efficiency level: IE3
Mains connection: 3~ 400 V / 50 Hz
Permitted voltage tolerance: +10 %
Rated speed: 2,900 1/min
Rated power P2: 1.10 kW
Rated current: 2.70 A
Power factor
Service factor: 1.5
Degree of protection: IP55
Insulation class: F
Motor protection: No

Fitting dimensions

Pipe connection on the suction side: G 1, PN 16
Pipe connection (pressure side): G 1, PN 16

Materials

Pump housing: 1.4301
Impeller: 1.4301
Shaft: 1.4301
Shaft seal: BQ7EGG
Gasket material: EPDM

Information for order placements

Weight approx.: 20.8 kg
Item number: 4240469