

**Customer**

# Technical data

## High-pressure multistage centrifugal pump Helix V 5201-1/16/E/KS/460-60

Project ID: Untitled project 2025-03-05 07:27:14.016

Project name  
Installation location  
Customer pos. No.

Date: 2025-03-05

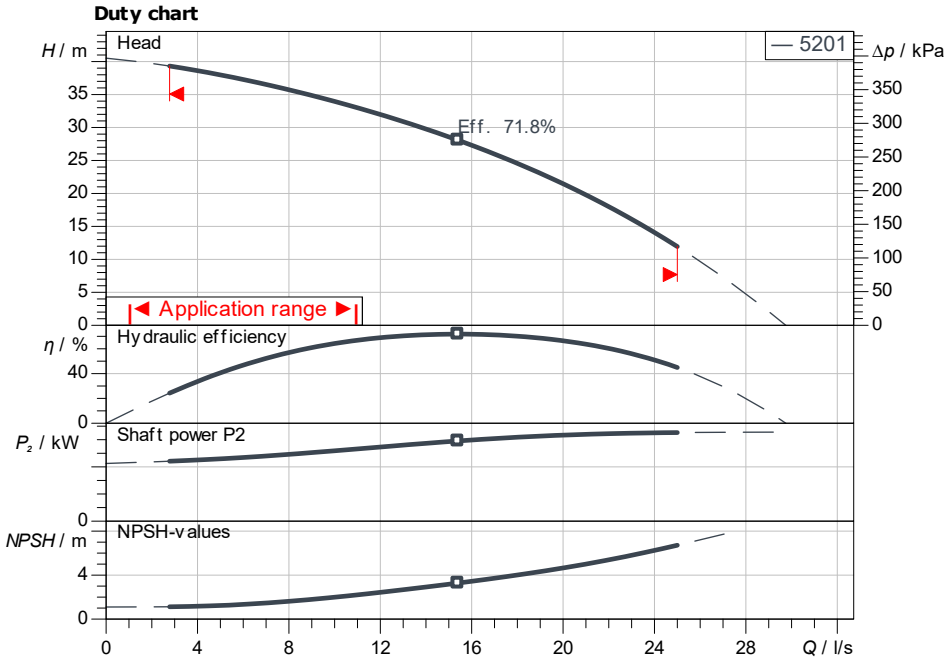

ISO 9906: 2012 3B

**Dimensions**

H	1,00
H2	616
X	196

mm

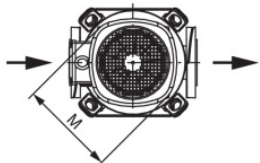
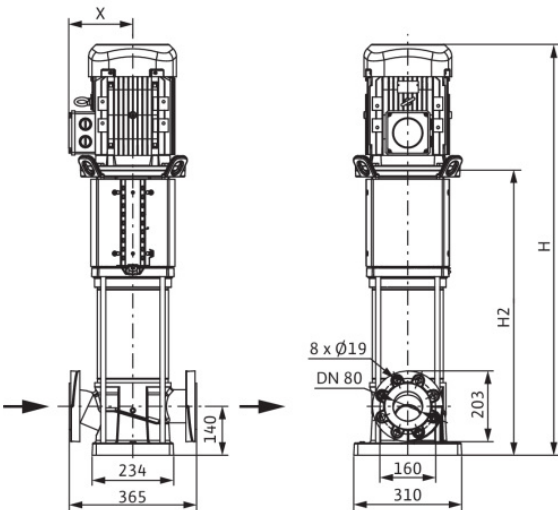
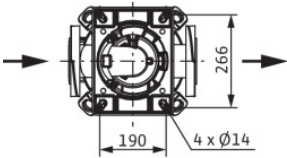

**Requested data**

Flow	
Head	
Media	Water 100 %
Fluid temperature	20.00 °C
Density	998.30 kg/m <sup>3</sup>
Kin. viscosity	1.00 mm <sup>2</sup> /s

**Hydraulic data (Duty point)**

Flow	
Head	
Shaft power P2	
Hydraulic efficiency	
NPSH	

**Product data**

High-pressure multistage centrifugal pump Helix V 5201-1/16/E/KS/460-60	
Max. operating pressure	1,600 kPa
Inlet pressure max.	10 bar
Fluid temperature	-20 °C ... +120 °C
Max. ambient temperature	50 °C
Minimum efficiency index (MEI)	

**Motordata per Motor/Pump**

Motor efficiency level	
Mains connection	3~ 400 V / 60 Hz
Permitted voltage tolerance	+ -10 %
Max. speed	2,923 1/min
Rated power P2	7.50 kW
Rated current	13.80 A
Power factor	0.87
Service factor	1.15
Efficiency	50% / 75% / 100%
Degree of protection	IP55
Insulation class	
Motor protection	PTC

**Fitting dimensions**

Pipe connection on the suction side	DN 80, PN 16
Pipe connection (pressure side)	DN 80, PN 16

**Materials**

Pump housing	1.4301
Impeller	1.4307
Shaft	1.4057
Shaft seal	BQ7EGG
Gasket material	EPDM

**Information for order placements**

Weight approx.	97 kg
Item number	4246765