

Contact
E-mail
Phone

Customer

Contact
E-mail
Phone

Dimensions

Sewage lifting unit; Single-pump system
DrainLift SANI-M.11M/4

Project ID Untitled project 2025-03-03 09:17:45.830

Project name
Installation location
Customer pos. No.

Date 2025-03-03

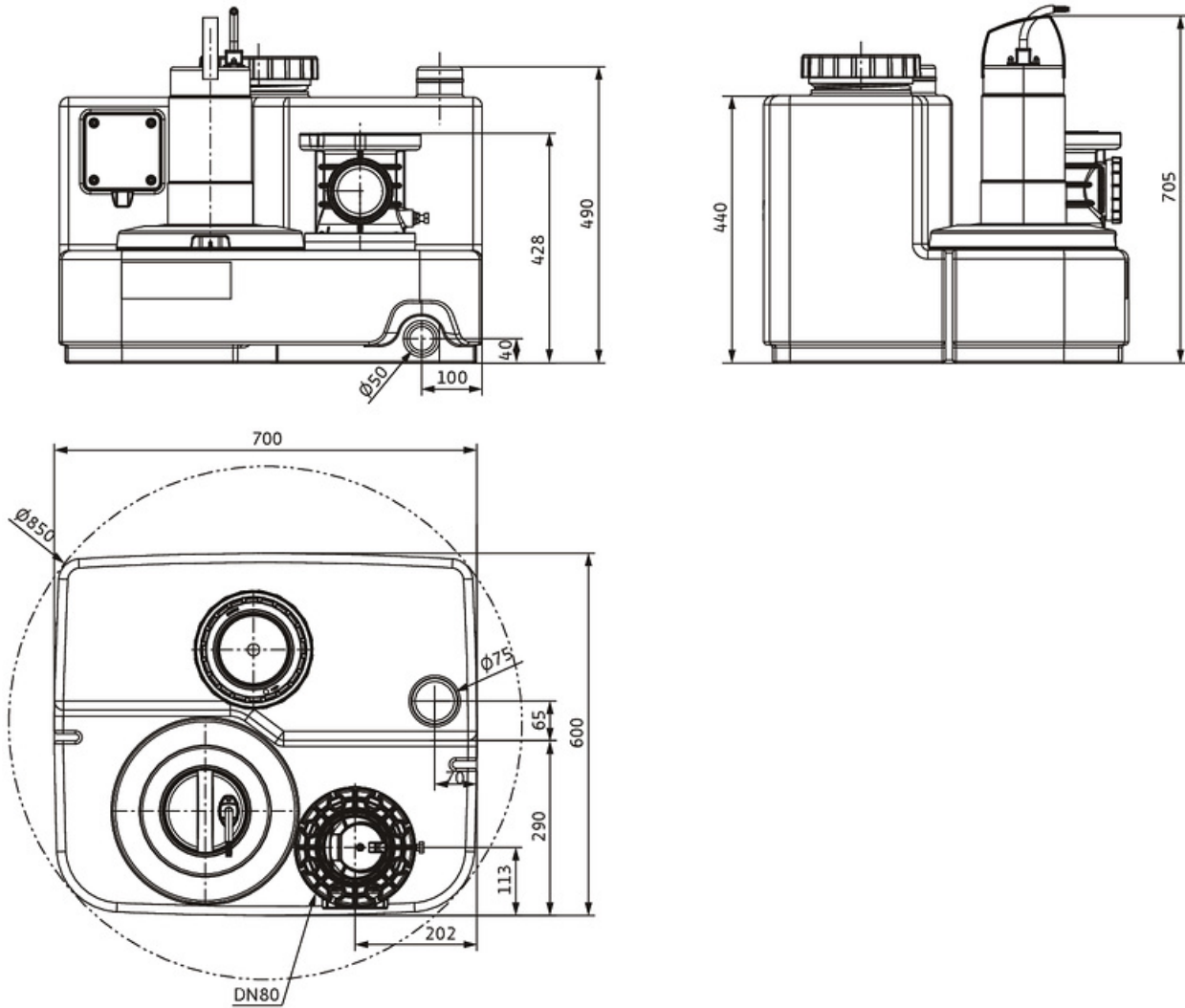

Stationary dry well installation

Suction side DN 110 (110 mm), PN 0,5/PN 10
Discharge side DN 80, PN 0,5/PN 10

Dimensions mm

Name	Value	Name	Value	Name	Value	Name	Value
------	-------	------	-------	------	-------	------	-------