

**Customer**

## Technical data

### Glanded standard pump

Atmos GIGA-NHT 100/250-55/2-S2

Project ID

Untitled project 2025-03-01 20:45:47.557

Project name

Installation location

Customer pos. No.

Date 2025-03-01

#### Duty chart

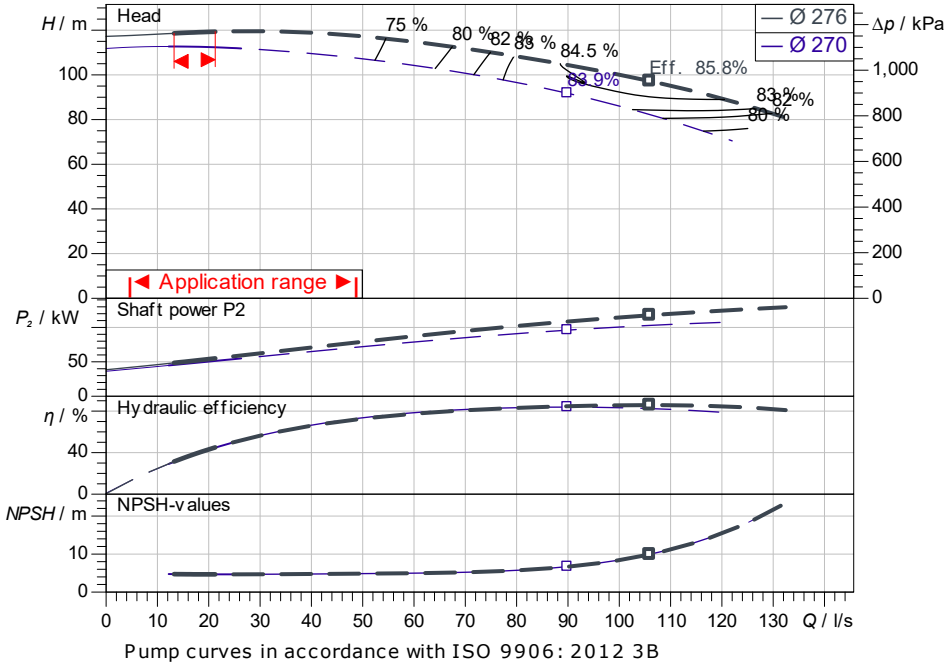

#### Requested data

Flow	
Head	
Media	Water 100 %
Fluid temperature	20.00 °C
Density	998.30 kg/m <sup>3</sup>
Kin. viscosity	1.00 mm <sup>2</sup> /s

#### Hydraulic data (Duty point)

Flow	
Head	
Shaft power P2	
Hydraulic efficiency	
NPSH	
Impeller size	276

#### Product data

Glanded standard pump	
Atmos GIGA-NHT 100/250-55/2-S2	
Max. operating pressure	2,500 kPa
Fluid temperature	-20 °C ... +350 °C
Max. ambient temperature	50 °C
Minimum efficiency index (MEI)	

#### Motordata per Motor/Pump

Motor efficiency level	IE3
Mains connection	3~ 400 V / 50 Hz
Permitted voltage tolerance	+10 %
Max. speed	2,960 1/min
Rated power P2	55.00 kW
Rated current	95.60 A
Power factor	0.85
Efficiency	50% / 75% / 100%
	93.6/94.4/94.4%
Degree of protection	IP55
Insulation class	F
Motor protection	PTC integrated

#### Fitting dimensions

Pipe connection on the suction side	DN 125, PN 25
Pipe connection (pressure side)	DN 100, PN 25
Port to Port	

#### Materials

Pump housing	EN-GJS-400-15
Impeller	EN-GJL-200
Shaft	1.4028
Shaft seal	AQ1VGG

#### Information for order placements

Weight approx.	
Item number	6095376

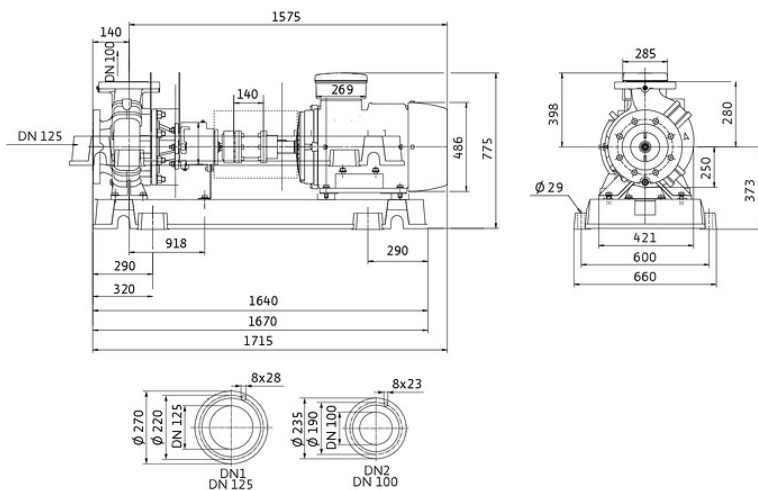

Dimensions mm



Contact  
E-mail  
Phone

Customer

Contact  
E-mail  
Phone

# Hydraulic data

## Glanded standard pump

### Atmos GIGA-NHT 100/250-55/2-S2

Project ID

Untitled project 2025-03-01 20:45:47.557

Project name

Installation location

Customer pos. No.

Date 2025-03-01

## Operating data

Rotational speed <b>2975 1/min</b>	Frequency <b>50 Hz</b>	Duty point <b>Q =</b>	<b>H =</b>	Suction port <b>DN 125</b>	Discharge port <b>DN 100</b>
---------------------------------------	---------------------------	--------------------------	------------	-------------------------------	---------------------------------

Power data referred to: Water; 20°C; 998.3kg/m³; 1.005mm²/s ±10 % tolerance with linear U/f frequency control

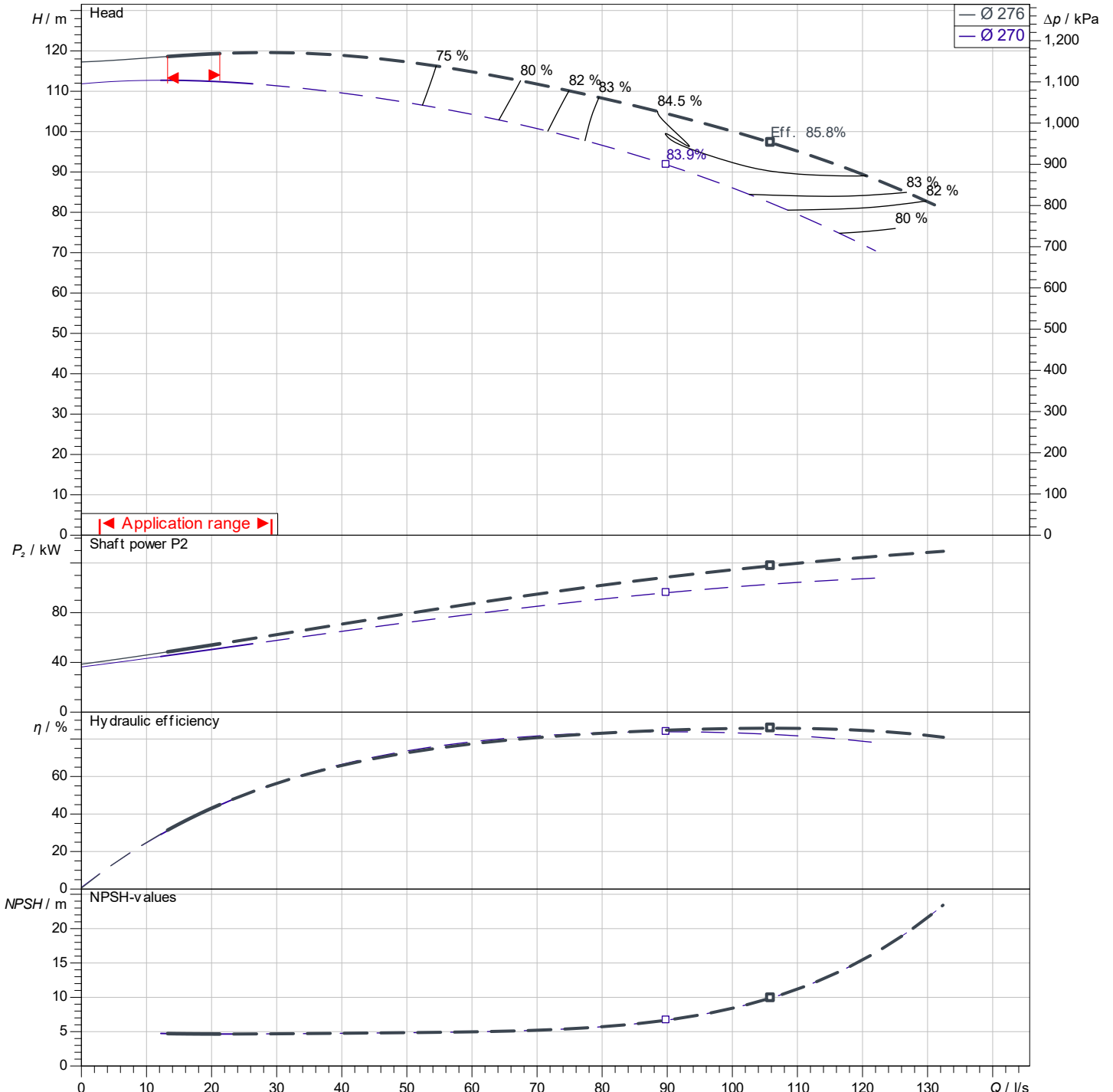

Pump curves in accordance with ISO 9906: 2012 3B

Contact  
E-mail  
Phone

**Customer**

Contact  
E-mail  
Phone

## Dimensions

### Glanded standard pump

Atmos GIGA-NHT 100/250-55/2-S2

Project ID

Untitled project 2025-03-01 20:45:47.557

Project name

Installation location

Customer pos. No.

Date 2025-03-01

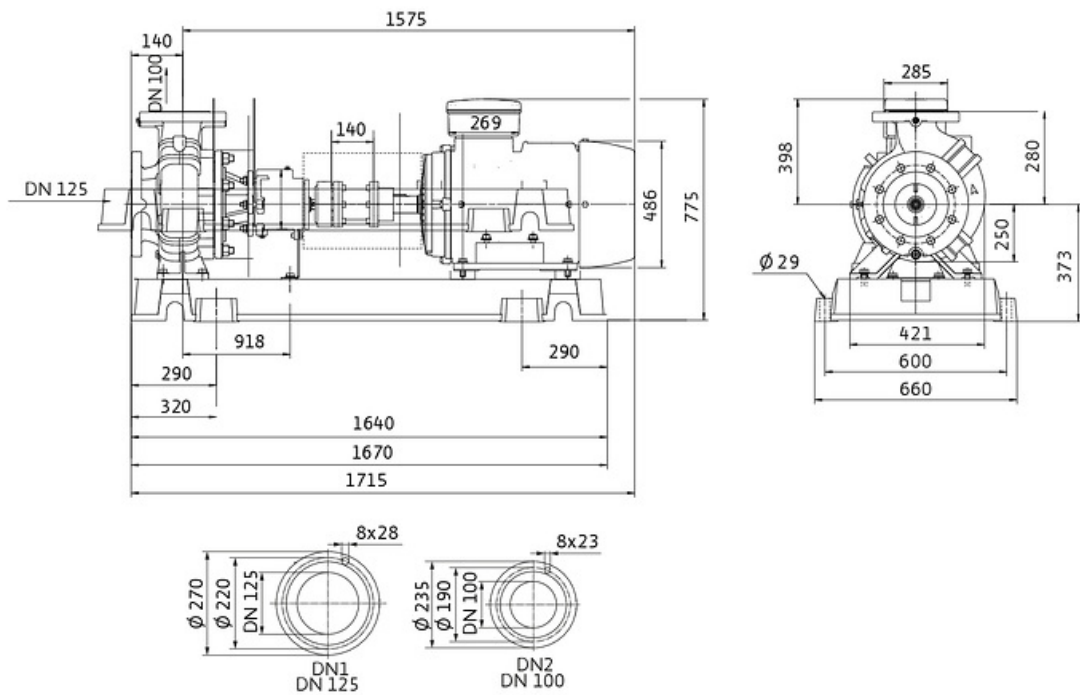

Standard

Suction side DN 125, PN 25

Discharge side DN 100, PN 25

**Dimensions** mm

Name	Value	Name	Value	Name	Value	Name	Value
------	-------	------	-------	------	-------	------	-------