

Customer

Technical data

Glanded standard pump Atmos GIGA-NHT 40/250-11/2-S2

Project ID Untitled project 2025-03-01 20:45:47.557

Project name
Installation location
Customer pos. No.

Date 2025-03-01

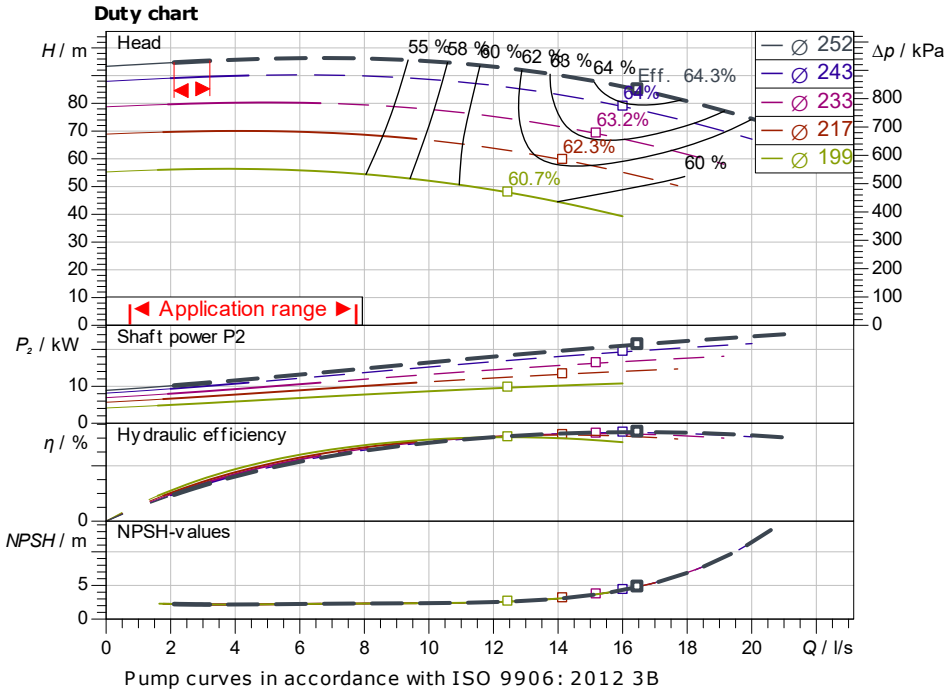

Requested data

Flow
Head
Media Water 100 %
Fluid temperature 20.00 °C
Density 998.30 kg/m³
Kin. viscosity 1.00 mm²/s

Hydraulic data (Duty point)

Flow
Head
Shaft power P_2
Hydraulic efficiency
NPSH
Impeller size 252

Product data

Glanded standard pump
Atmos GIGA-NHT 40/250-11/2-S2
Max. operating pressure 2,500 kPa
Fluid temperature -20 °C ... +350 °C
Max. ambient temperature 50 °C
Minimum efficiency index (MEI)

Motordata per Motor/Pump

Motor efficiency level IE3
Mains connection 3~ 400 V / 50 Hz
Permitted voltage tolerance +10 %
Max. speed 2,925 1/min
Rated power P_2 11.00 kW
Rated current 19.60 A
Power factor 0.85
Efficiency 50% / 75% / 100% 90.6/91.1/91.2%
Degree of protection IP55
Insulation class F
Motor protection PTC integrated

Fitting dimensions

Pipe connection on the suction side DN 65, PN 25
Pipe connection (pressure side) DN 40, PN 25
Port to Port

Materials

Pump housing EN-GJS-400-15
Impeller EN-GJL-200
Shaft 1.4028
Shaft seal AQ1VGG

Information for order placements

Weight approx.
Item number 6095356

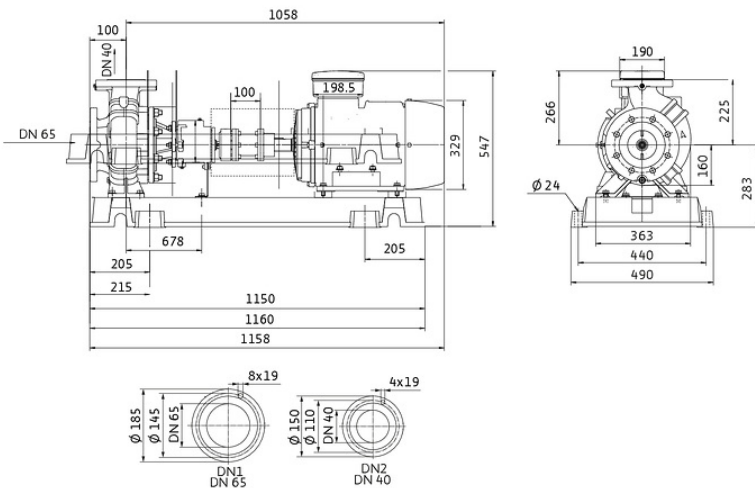

Dimensions mm



Contact
E-mail
Phone

Customer

Contact
E-mail
Phone

Hydraulic data

Glanded standard pump

Atmos GIGA-NHT 40/250-11/2-S2

Project ID

Untitled project 2025-03-01 20:45:47.557

Project name

Installation location

Customer pos. No.

Date 2025-03-01

Operating data

Rotational speed 2965 1/min	Frequency 50 Hz	Duty point Q =	H =	Suction port DN 65	Discharge port DN 40
---------------------------------------	---------------------------	--------------------------	------------	------------------------------	--------------------------------

Power data referred to: Water; 20°C; 998.3kg/m³; 1.005mm²/s ±10 % tolerance with linear U/f frequency control

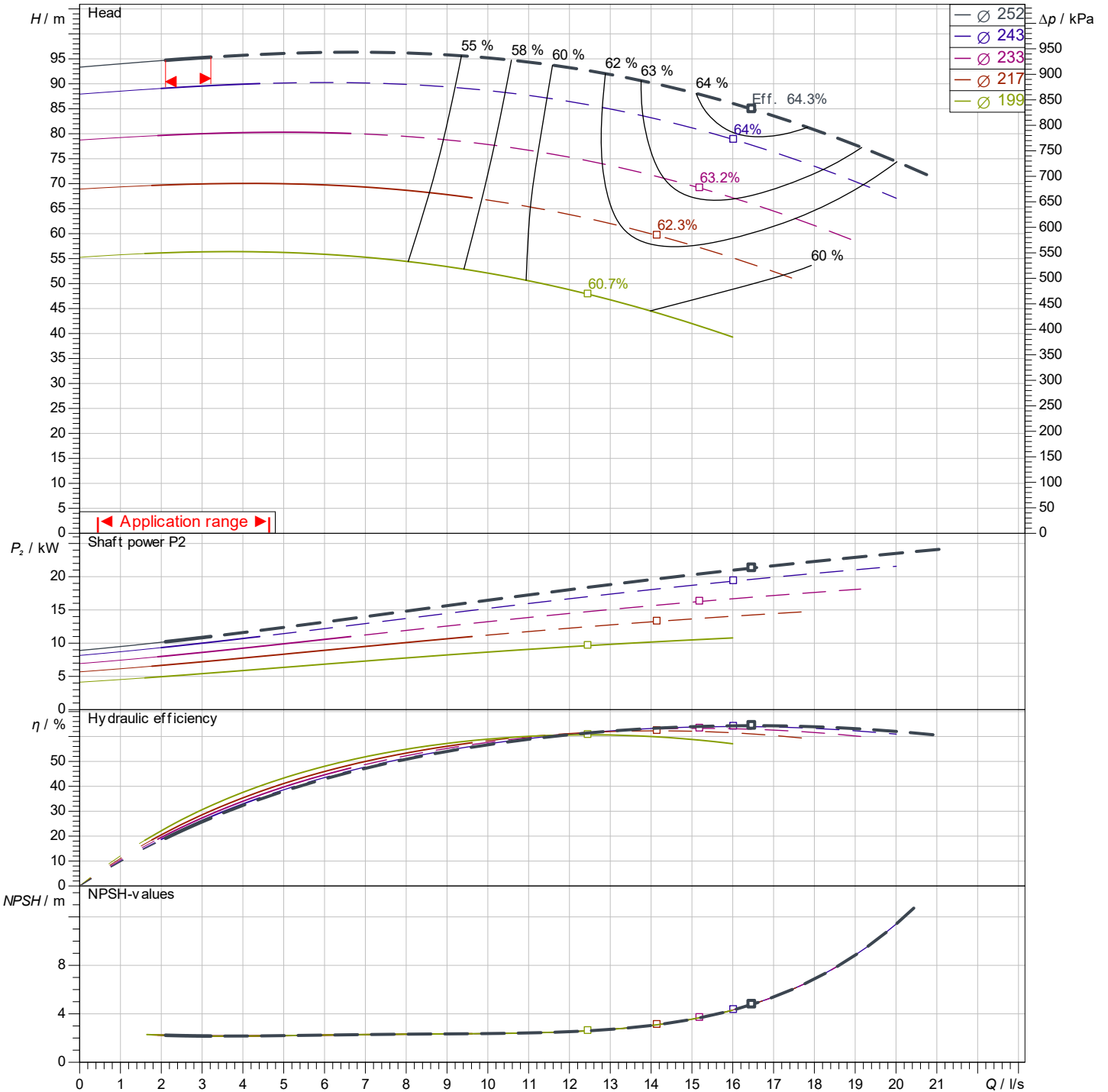

Pump curves in accordance with ISO 9906: 2012 3B

Contact
E-mail
Phone

Customer

Contact
E-mail
Phone

Dimensions

Glanded standard pump
Atmos GIGA-NHT 40/250-11/2-S2

Project ID Untitled project 2025-03-01 20:45:47.557

Project name
Installation location
Customer pos. No.

Date 2025-03-01

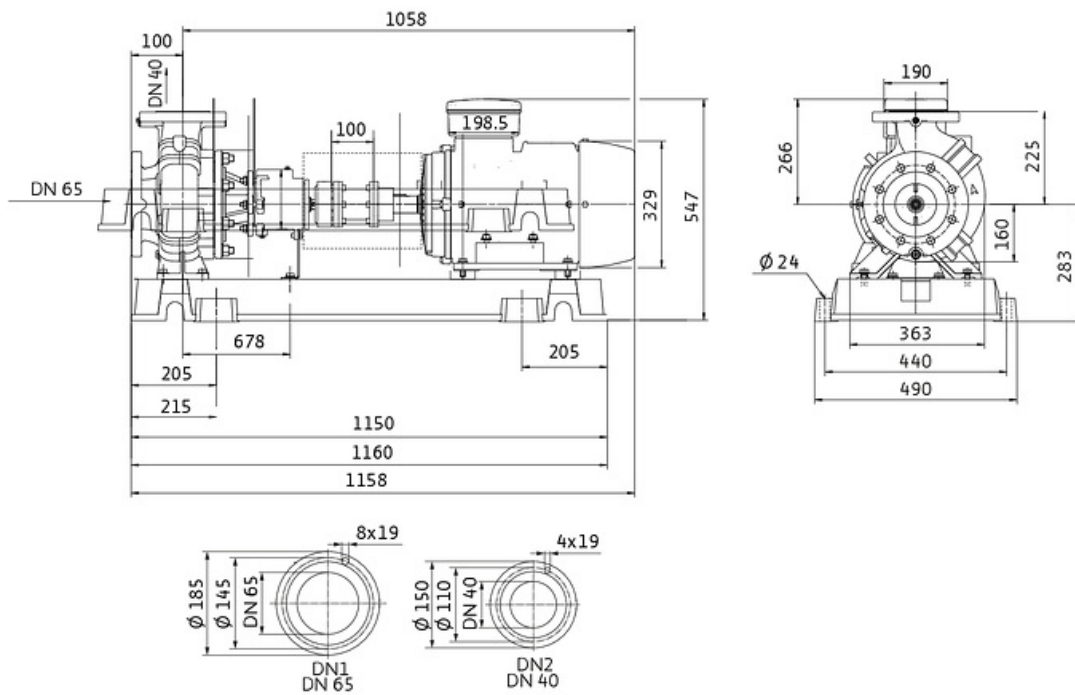

Standard

Suction side DN 65, PN 25

Discharge side DN 40, PN 25

Dimensions mm

Name	Value	Name	Value	Name	Value	Name	Value
------	-------	------	-------	------	-------	------	-------