

**Customer**

## Technical data

### Glanded monobloc pump Atmos BST 25/180-2.2/2-H12-V1

Project ID                      Untitled project 2025-03-01 17:12:44.130

Project name  
Installation location  
Customer pos. No.

Date                      2025-03-01

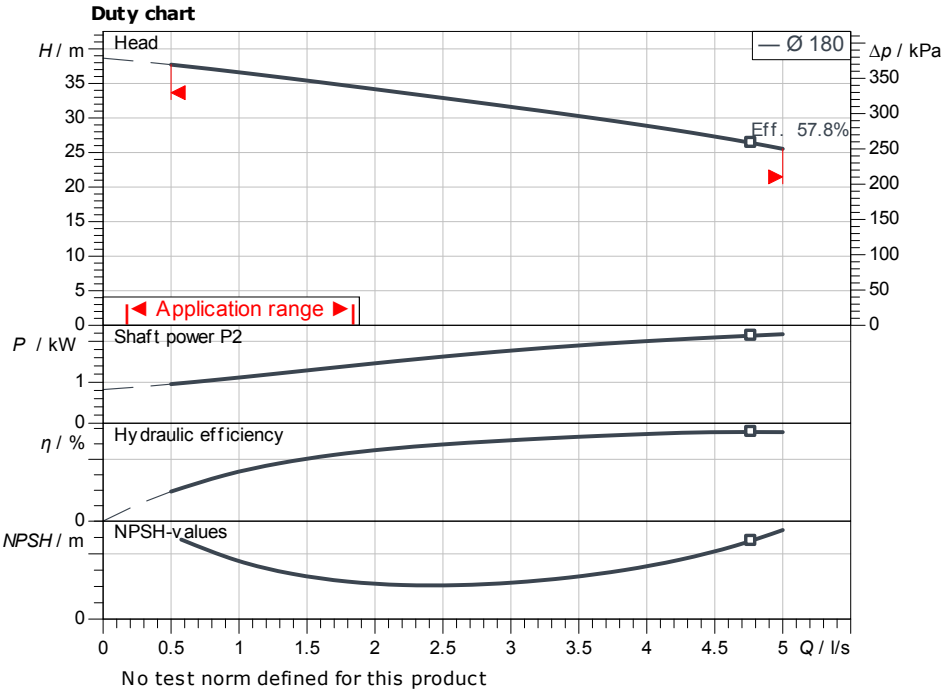

#### Requested data

Flow	
Head	
Media	Water 100 %
Fluid temperature	20.00 °C
Density	998.30 kg/m <sup>3</sup>
Kin. viscosity	1.00 mm <sup>2</sup> /s

#### Hydraulic data (Duty point)

Flow	
Head	
Shaft power P2	
Hydraulic efficiency	
NPSH	
Impeller size	180

#### Product data

Glanded monobloc pump	
Atmos BST 25/180-2.2/2-H12-V1	
Max. operating pressure	1,000 kPa
Fluid temperature	-20 °C ... +120 °C
Max. ambient temperature	50 °C
Minimum efficiency index (MEI)	≥ 0.4

#### Motordata per Motor/Pump

Motor efficiency level	IE3
Mains connection	3~ 400 V / 50 Hz
Permitted voltage tolerance	+6 %
Max. speed	2,900 1/min
Rated power P2	2.20 kW
Rated current	4.30 A
Power factor	0.85
Efficiency	
50% / 75% / 100%	//%
Degree of protection	IP55
Insulation class	F
Motor protection	

#### Fitting dimensions

Pipe connection on the suction side	G 1 1/2, PN 10
Pipe connection (pressure side)	G 1, PN 10
Port to Port	

#### Materials

Pump housing	1.4401
Impeller	1.4401
Shaft	1.4401
Shaft seal	B9Q1EG

#### Information for order placements

Weight approx.	
Item number	9187131

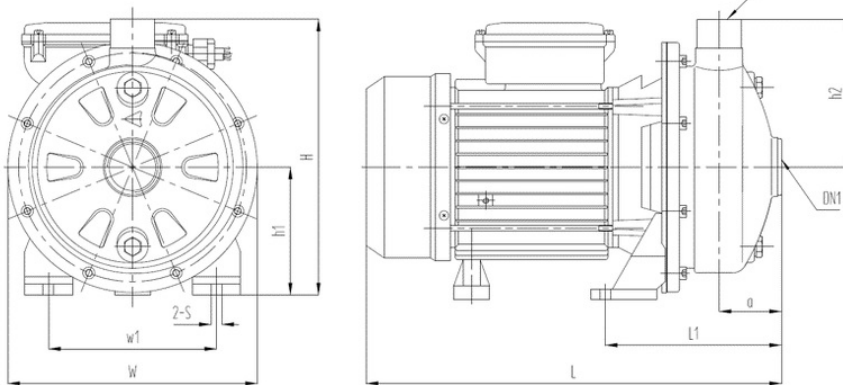

Dimensions		mm	
A	53	H2	129
DN1	G 1 1/2, PN	L	377
DN2	G 1, PN 1	L1	162
H	247	W	230
H1	118	W1	140



Contact  
E-mail  
Phone

**Customer**

Contact  
E-mail  
Phone

## Hydraulic data

Glanded monobloc pump  
Atmos BST 25/180-2.2/2-H12-V1

Project ID                      Untitled project 2025-03-01 17:12:44.130

Project name  
Installation location  
Customer pos. No.

Date                      2025-03-01

## Operating data

Rotational speed <b>2888 1/min</b>	Frequency <b>50 Hz</b>	Duty point <b>Q =</b>	<b>H =</b>	Suction port <b>G 1½</b>	Discharge port <b>G 1</b>
---------------------------------------	---------------------------	--------------------------	------------	-----------------------------	------------------------------

Power data referred to:                      Water; 20°C; 998.3kg/m<sup>3</sup>; 1.005mm<sup>2</sup>/s                      ±10 % tolerance with linear U/f frequency control

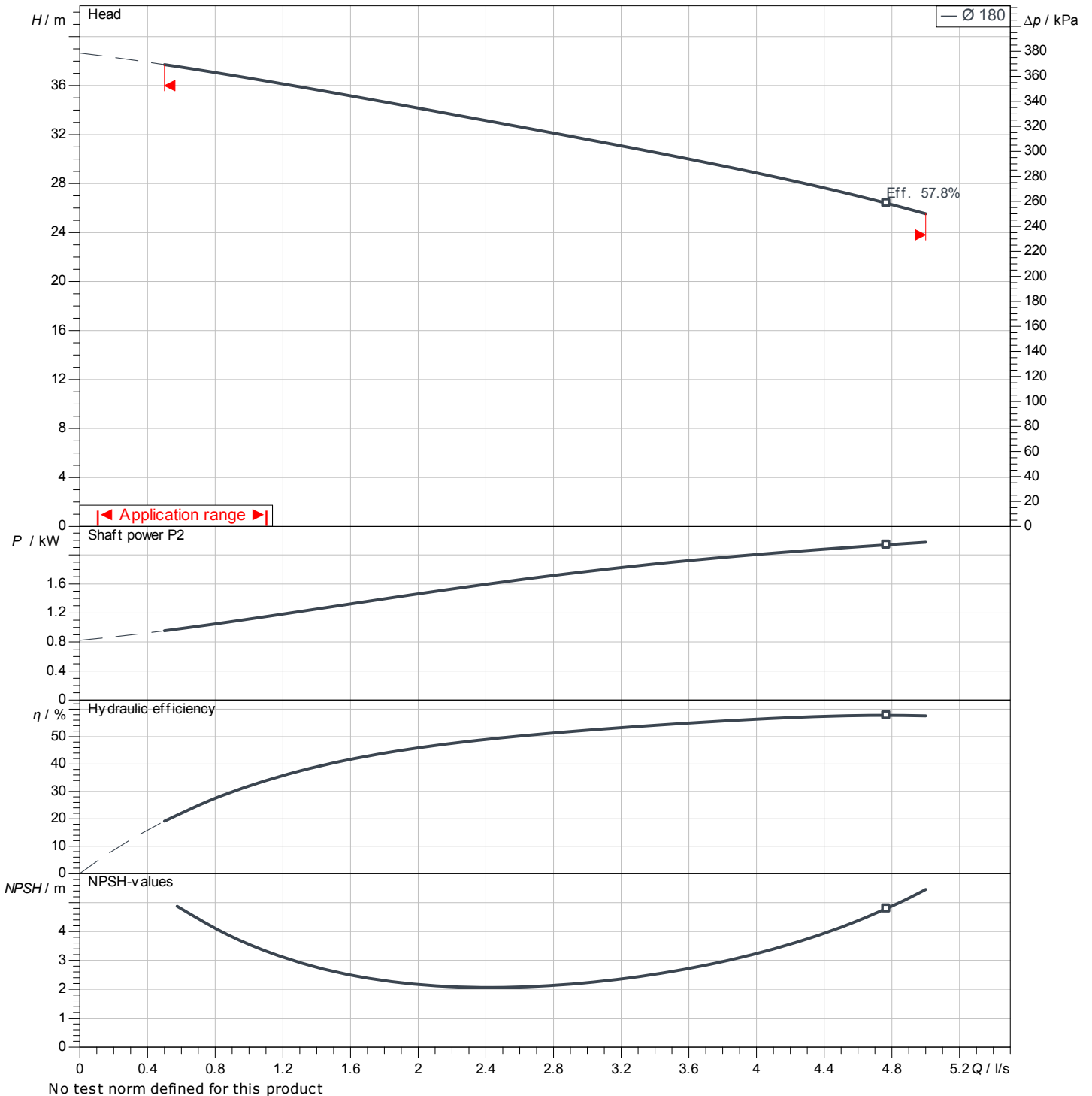

No test norm defined for this product

Contact  
E-mail  
Phone

**Customer**

Contact  
E-mail  
Phone

## Dimensions

Glanded monobloc pump  
Atmos BST 25/180-2.2/2-H12-V1

Project ID                      Untitled project 2025-03-01 17:12:44.130

Project name  
Installation location  
Customer pos. No.

Date                      2025-03-01

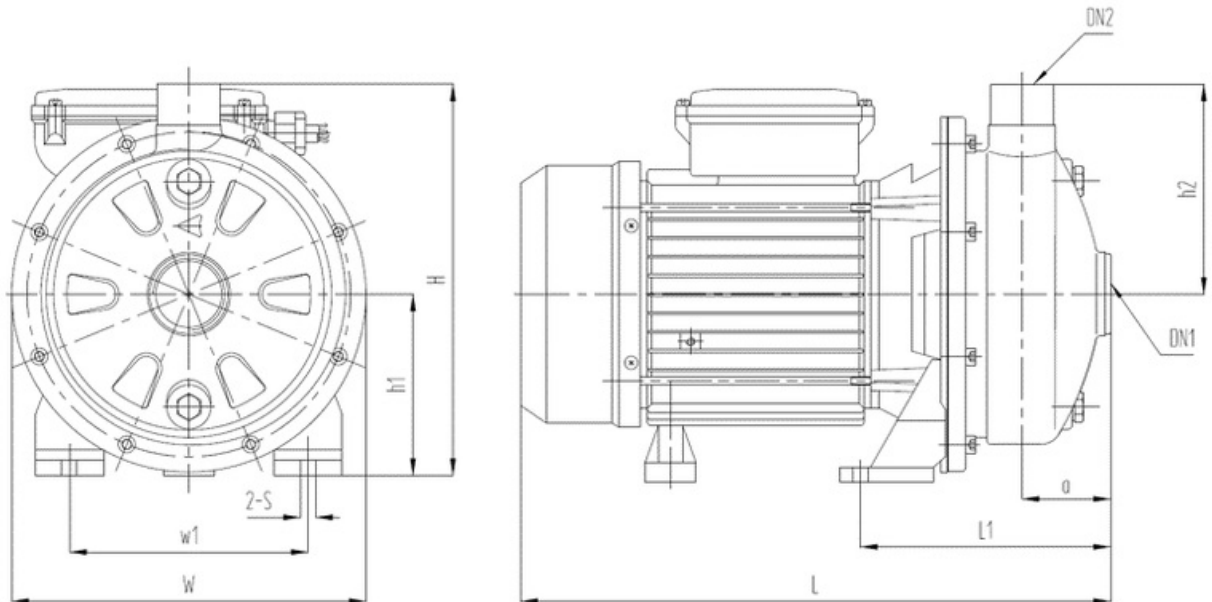

**Standard**

Suction side                      G 1½, PN 10  
Discharge side                      G 1, PN 10

**Dimensions**                      mm

Name	Value	Name	Value	Name	Value	Name	Value
A	53	L1	162				
DN1	G 1½, PN 10	W	230				
DN2	G 1, PN 10	W1	140				
H	247						
H1	118						
H2	129						
L	377						