

**Customer**

## Technical data

### Glanded standard pump Atmos GIGA-N 50/315-55/2

Project ID: Untitled project 2025-03-03 06:26:03.775

Project name  
Installation location  
Customer pos. No.

Date: 2025-03-03

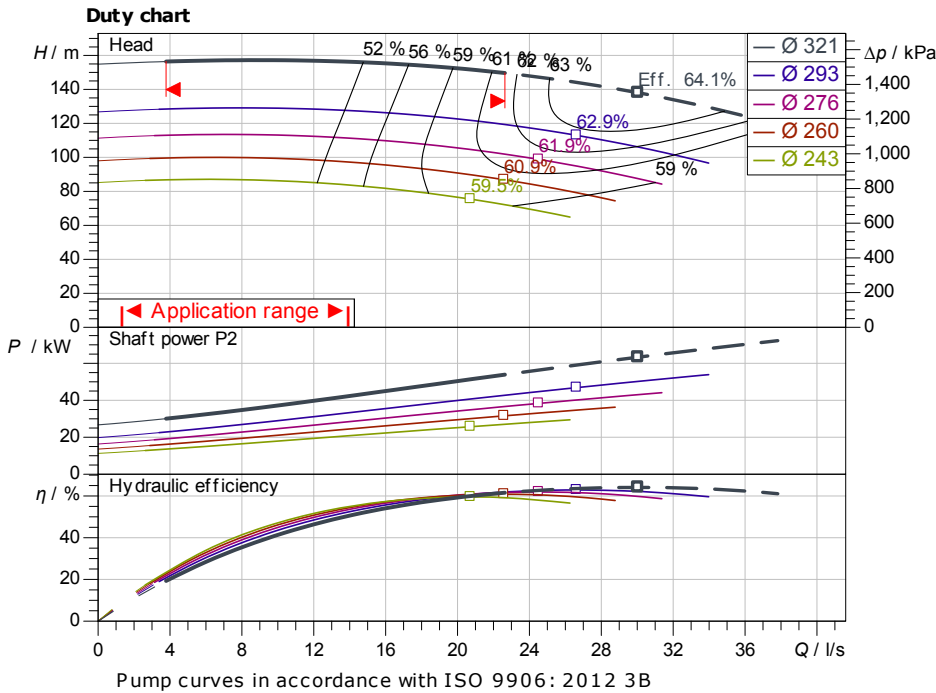

#### Requested data

Flow  
Head  
Media: Water 100 %  
Fluid temperature: 20.00 °C  
Density: 998.30 kg/m<sup>3</sup>  
Kin. viscosity: 1.00 mm<sup>2</sup>/s

#### Hydraulic data (Duty point)

Flow  
Head  
Shaft power P2  
Hydraulic efficiency  
NPSH  
Impeller size: 321

#### Product data

Glanded standard pump  
Atmos GIGA-N 50/315-55/2  
Max. operating pressure: 1,600 kPa  
Fluid temperature: -20 °C ... +140 °C  
Max. ambient temperature: 40 °C  
Minimum efficiency index (MEI): ≥ 0.4

#### Motordata per Motor/Pump

Motor efficiency level: IE3  
Mains connection: 3~ 400 V / 50 Hz  
Permitted voltage tolerance: +10 %  
Max. speed: 2,960 1/min  
Rated power P2: 55.00 kW  
Rated current: 95.60 A  
Power factor: 0.85  
Efficiency: 50% / 75% / 100% → 93.6/94.4/94.4%  
Degree of protection: IP55  
Insulation class: F  
Motor protection: PTC integrated

#### Fitting dimensions

Pipe connection on the suction side: DN 65, PN 16  
Pipe connection (pressure side): DN 50, PN 16  
Port to Port

#### Materials

Pump housing: 5.1301/EN-GJL-250  
Impeller: EN-GJL-200  
Lantern: 5.1301/EN-GJL-250  
Shaft: 1.4021  
Shaft seal: AQ1EGG

#### Information for order placements

Weight approx.: 853 kg  
Item number: 6086479

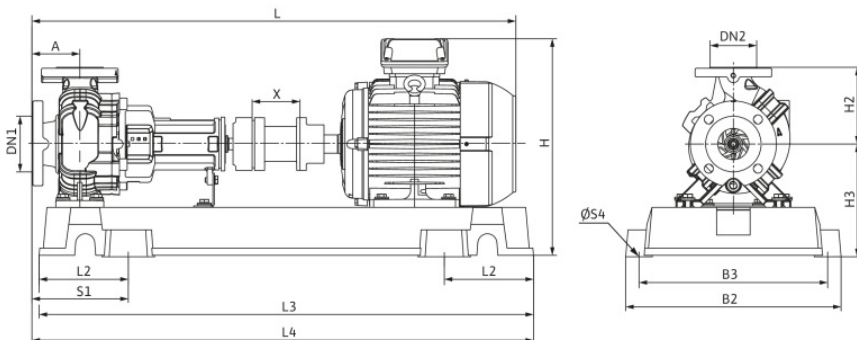

#### Dimensions

mm

A	125	H	775	L3	1,640
B2	660	H2	280	L4	1,670
B3	600	H3	373	S1	320
DN1	DN 65, P	L	1,660	S4	29
DN2	DN 50, P	L2	290	X	100



Contact  
E-mail  
Phone

**Customer**

Contact  
E-mail  
Phone

## Hydraulic data

Glanded standard pump  
Atmos GIGA-N 50/315-55/2

Project ID                      Untitled project 2025-03-03 06:26:03.775

Project name  
Installation location  
Customer pos. No.

Date                      2025-03-03

## Operating data

Rotational speed <b>2975 1/min</b>	Frequency <b>50 Hz</b>	Duty point <b>Q =</b>	<b>H =</b>	Suction port <b>DN 65</b>	Discharge port <b>DN 50</b>
---------------------------------------	---------------------------	--------------------------	------------	------------------------------	--------------------------------

Power data referred to:                      Water; 20°C; 998.3kg/m³; 1.005mm²/s                      ±10 % tolerance with linear U/f frequency control

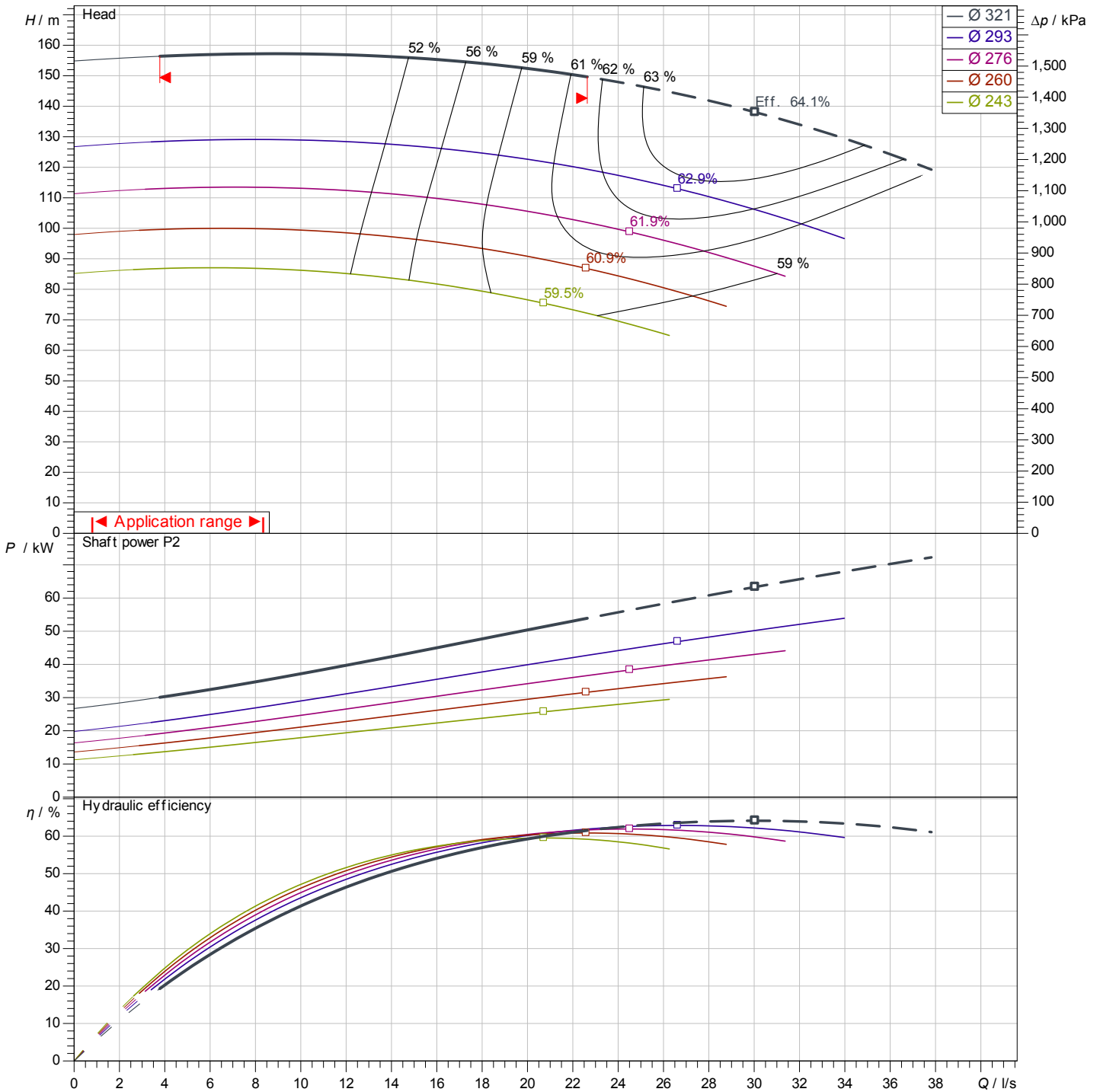

Pump curves in accordance with ISO 9906: 2012 3B

Contact  
E-mail  
Phone

**Customer**

Contact  
E-mail  
Phone

## Dimensions

Glanded standard pump  
Atmos GIGA-N 50/315-55/2

Project ID                      Untitled project 2025-03-03 06:26:03.775

Project name  
Installation location  
Customer pos. No.

Date                      2025-03-03



**Coupling with spacer**

Suction side                      DN 65, PN 16  
Discharge side                      DN 50, PN 16

**Dimensions**                      mm

Name	Value	Name	Value	Name	Value	Name	Value
A	125	H3	373	X	100		
B2	660	L	1,660				
B3	600	L2	290				
DN1	DN 65, PN 16	L3	1,640				
DN2	DN 50, PN 16	L4	1,670				
H	775	S1	320				
H2	280	S4	29				